

O P E R A T I N G M A N U A L



VORTEX™

Refrigerant Recovery Machine



Thank you for buying the INFICON® Vortex™ Refrigerant Recovery Machine!

To get the best performance from your Vortex, please read this manual carefully before you start using the recovery machine.

Safety First!



When found on the machine, this international symbol is intended to alert the user to the presence of important operating, safety and maintenance (servicing) instructions in this Manual. As used in the Manual, it is intended to draw your attention to critical items.

It is important to read this entire Manual and be familiar with its contents before using the machine!

The Vortex is a Recovery Machine for a broad range of refrigerants. Recovering refrigerants into a separate storage tank involves a process of gas compression, resulting in high pressures within the machine, the connecting hoses and the storage tank. High pressure systems must always be treated with care and respect to prevent careless accidents.

Responsibility

INFICON Vortex must only be operated by a Qualified Technician who has been properly trained in the care and use of such equipment and in the recovery process itself. Use of this equipment by unqualified personnel is potentially dangerous and should not be attempted.

Trademarks

The trademarks of the products mentioned in this manual are held by the companies that produce them.

INFICON®, Vortex™, D-TEK™, TEK-Mate®, and Wey-TEK™ are trademarks of INFICON Inc.

All other brand and product names are trademarks or registered trademarks of their respective companies.

The information contained in this manual is believed to be accurate and reliable. However, INFICON assumes no responsibility for its use and shall not be liable for any special, incidental, or consequential damages related to the use of this product.

©2003 All rights reserved.

Reproduction or adaptation of any part of this manual without permission is unlawful.

Declaration Of Conformity

Vortex Model # 708-202-P10 is CE Certified.

This is to certify that this equipment, designed and manufactured by:

INFICON Inc.
Two Technology Place
East Syracuse, NY 13057 USA

Meets the essential safety requirements of the European Union and is placed on the market accordingly. It has been constructed in accordance with good engineering practice in safety matters in force in the Community and does not endanger the safety of persons, domestic animals or property when properly installed and maintained and used in applications for which it was made.

Equipment Description Vortex Refrigerant Recovery Unit
Applicable Directives 73/23/EEC as amended by 93/68/EEC
89/336/EEC as amended by 93/68/EEC
Applicable Standards EN 61010-1 : 2001
EN 55011, Group 1, Class A : 1991
EN 50082-1 : 1992
CE Implementation June 2, 2003
Authorized Representative Gary W. Lewis
Vice President - Quality Assurance
INFICON Inc.

Preface

Table Of Contents

1.0	Safety Precautions	2
2.0	Specifications, Features and Warranty	3
2.1	Vortex Specifications	3
2.2	Warranty	4
3.0	Setup and Operation	4
3.1	Getting Started	4
3.2	Normal Recovery Operation	5
3.3	PURGING the Vortex	6
3.4	Push-Pull Operation	7
3.5	Cooling The Recovery Tank	8
3.6	Special Operating Notes	10
4.0	Maintenance	10
4.1	Introduction	10
5.0	Troubleshooting	10
6.0	Service	12
6.1	General	12
6.2	Electrical Schematic	13

1.0 Safety Precautions



THIS EQUIPMENT MUST ALWAYS BE OPERATED BY A QUALIFIED TECHNICIAN WHO IS FAMILIAR WITH REFRIGERANT SYSTEMS, REFRIGERANTS, REFRIGERANT SAFETY AND LAWS PERTAINING TO REFRIGERANT USAGE.



READ THIS MANUAL and become familiar with the specifications and operation of this machine prior to use.



WEAR APPROPRIATE SAFETY PROTECTION APPAREL such as gloves, eye protection and foot protection when working on refrigeration systems.



REFRIGERANT VAPOR CAN BE HAZARDOUS AND ITS BY PRODUCTS CAN BE LETHAL — work only in well ventilated areas. When working indoors, ensure there is adequate airflow in the work space and install a separate circulation fan if necessary. DO NOT WORK IN AN ENCLOSED AREA without special safety equipment as appropriate for the conditions.



KNOW THE PROPER SAFETY AND HANDLING REQUIREMENTS for the Refrigerant being recovered by reviewing the Material Safety Data Sheets (MSDS) and the Temperature - Vapor Pressure information.



PERFORM LEAK DETECTION in accordance with recommended practice only. For best results use only a refrigerant detector such as the INFICON D-TEK™ or TEK-Mate®. NEVER USE OXYGEN for this process as it can become an explosive mixture in the presence of oil and pressure.



USE CAUTION WHEN OPERATING. This equipment should be used in clean, dry areas only. Be certain the power cord and the equipment are not placed in residual water or other potentially dangerous locations.



NEVER OVERFILL A STORAGE CONTAINER. The use of a refrigerant scale, such as the INFICON Wey-TEK™, is required to prevent overflow. OVERFILLED TANKS CAN RUPTURE EXPLOSIVELY!



OPEN SERVICE OR CYLINDER VALVES SLOWLY to ensure that all connections are tight and there is no danger.



DISCONNECT POWER before moving or servicing the INFICON Vortex.



This unit should be opened only by a technically qualified person who has been trained in basic electronics and refrigeration. The risk of **ELECTRIC SHOCK** and exposure to **HOT** compressor parts is possible if the unit is opened.



TO REDUCE THE RISK OF FIRE, EXTENSION CORDS SHOULD NOT BE USED with this equipment as the wiring can overheat under conditions of high current draw. If an extension cord is absolutely necessary, its length should be as short as possible and it should contain size 16 AWG or larger wiring.



FLAMMABLE ENVIRONMENTS ARE DANGEROUS when any machine is used because motors and switches can generate sparks. This equipment should be used in locations with mechanical ventilation providing at least four air changes per hour, or the equipment should be located at least 18” above the floor. **DO NOT USE THIS EQUIPMENT IN THE VICINITY OF SPILLED OR OPEN CONTAINERS OF GASOLINE OR ANY OTHER FLAMMABLE LIQUID.**

2.0 Specifications, Features and Warranty

2.1 Vortex Specifications

Refrigerants	R-12, R-134A, R-401C, R-500, R-401A, R-409A, R-401B, R-22, R-502, R-407C, R-402B, R-408A, R-407A, R-404A, R-402A, R-507, R-407B, R410A
Power	230 V(ac), 50/60 Hz, 4A
Compressor:	1/3 HP Oilless, No inlet valve, DC Motor Drive
Cooling:	Fan driven off DC compressor motor
Protection:	High Pressure Switch Cutoff at 3789 kPa Compressor motor thermally protected
Pressure	Low side design pressure 3500 kPa High side design pressure 5500 kPa
Temperature	Operating Range 10 to 40 °C
Case	Blow-Molded, High Impact Strength
Size	457.2 mm x 241.3 mm x 368.3 mm
Weight	11.79 kg

2.2 Warranty

INFICON warrants your Vortex Refrigerant Recovery Machine to be free from defects of materials or workmanship for one year from the date of purchase. INFICON does not warrant any machine that has been subjected to misuse, negligence, or accident, or has been repaired or altered by anyone other than INFICON.

The Compressor is warranted for a period of one year by the manufacturer. To keep this WARRANTY in force it is required that a standard filter or filter drier be used on the Inlet Port or Hose at all times to prevent particulates from entering the compressor. FAILURE TO USE A FILTER WILL VOID THE COMPRESSOR WARRANTY.

INFICON's liability is limited to machines returned to INFICON, transportation prepaid, not later than thirty (30) days after the warranty period expires, and which INFICON judges to have malfunctioned because of defective materials or workmanship. INFICON's liability is limited to, at its option, repairing or replacing the defective machine or part.

This WARRANTY is in lieu of all other warranties, express or implied, whether of MERCHANTABILITY or of FITNESS FOR A PARTICULAR PURPOSE or otherwise. All such other warranties are expressly disclaimed.

INFICON shall have no liability in excess of the price paid to INFICON for the machine plus return transportation charges prepaid. INFICON shall have no liability for any incidental or consequential damages. All such liabilities are EXCLUDED.

3.0 Setup and Operation

3.1 Getting Started



Only personnel who have been properly trained in the use and operation of Refrigeration Systems, Refrigerants and Service Equipment should operate this equipment. Failure to follow proper safety precautions could result in personal injury or death.



Review the full contents of this Manual before attempting to use the Vortex in actual service.

Identify the refrigerant to be recovered and prepare the Vortex for use by installing an approved filter, hoses and optional shutoff cable per the diagram below.

Connect the AC Power cord to a circuit that is protected by a 15 amp breaker. Use an extension cord only when absolutely necessary to perform the service — be sure it is the minimum length required, that it contains a safety ground wire and that it contains wires sized 16 AWG or larger.

Check all connections to ensure they are tight before starting the Recovery Operation.

When recovering refrigerant, it may be necessary to throttle the Manifold Gauge control valve(s) or the Vortex's INLET Valve when a significant amount of liquid is present. This is required if a loud “knocking” sound is heard from the compressor. While the Compressor in the Vortex is tolerant of liquid, no compressor will run on 100% liquid without damage for more than a few minutes. In addition, a liquid “slug” can cause the High Pressure shutoff to activate, thus adding time to the process. It is thus important to open the valves slowly and monitor the process carefully. Should the compressor start to “Knock”, rotate the INLET valve clockwise until the “knocking” stops. This can also be accomplished by adjusting the Manifold Gauge valves. Exercise care to ensure that the compressor is not damaged in this way as it will void the warranty.

 **It is necessary to use a Refrigerant Scale to ensure that the tank is not filled to more than 80% of its capacity by weight. When operating in the NORMAL RECOVERY or PUSH-PULL mode, it is possible to overfill the tank. Check the tank weight before transporting if you are not sure. OVERFILLED TANKS CAN RUPTURE EXPLOSIVELY!**

3.2 Normal Recovery Operation

- 1 Connect all cables and hoses as described in [section 3.1](#) and as shown in [Figure 3-1](#) below. Ensure that they are tight and routed in such a way that they will not interfere with the operation.

Figure 3-1 Setup Procedure For Normal Refrigerant Recovery

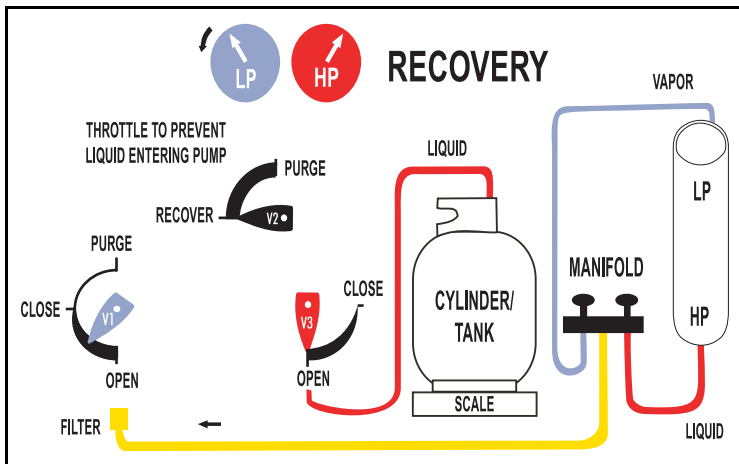

- 2** Make sure that the hose from the Vortex to the Recovery Tank is attached to the LIQUID PORT. Open the tank's LIQUID PORT valve, keeping the VAPOR port closed.
- 3** CLOSE the INLET valve (V1).
- 4** OPEN the DISCHARGE valve (V3) to its fully open position.
- 5** SET the PURGE/RECOVERY valve (V2) to the RECOVERY position.
- 6** Open the Manifold Gauge LIQUID valve slowly and verify that no leaks are present. Extracting as much liquid as possible will speed up the recovery process.
- 7** Switch ON the Vortex.
- 8** MONITOR the inlet pressure (LP, Low Pressure Gauge) and SLOWLY OPEN the Vortex's INLET valve (V1). THROTTLE the INLET valve or the Manifold Gauge's Liquid and Vapor valves if too much liquid is entering the machine.
- 9** When the liquid has been transferred, OPEN the INLET valve (V1) fully to transfer the remaining VAPOR. Ensure that the Manifold Gauge valves (liquid and vapor) are also fully opened.
- 10** Continue to operate until the required VACUUM has been pulled on the system, as indicated by the LP gauge. Switch OFF the Vortex, CLOSE the INLET (V1), and wait for 5 minutes. If the Pressure in the system, as noted on the Manifold Gauge, rises above 0 bar, refrigerant is still present. If this is the case, REOPEN the INLET (V1), RESTART the Vortex, and run until the required VACUUM is reached again. Repeat this process until all the refrigerant is removed resulting in a final reading, after the 5 minute period, of 0 bar or less.
- 11** IMMEDIATELY PURGE the Vortex per the procedure as described in [section 3.3](#) of this Manual.

3.3 PURGING the Vortex

- 1** Rotate the PURGE/RECOVER valve (V2) to the PURGE position. Rotate valve V3 to OPEN. See [Figure 3-2](#).
- 2** Switch the POWER ON and rotate the INLET valve (V1) slowly to the PURGE. Prevent flooding the compressor with liquid, do not rotate the V1 valve quickly.
- 3** Observe the LP Gauge and continue to run the unit until a VACUUM of at least -0.6 bar is achieved. Switch the POWER OFF and immediately CLOSE the Recovery Tank's valve. The INLET valve (V1) should be returned to the CLOSE position. Finally close V3.

4 IMPORTANT — RETURN V2 TO RECOVERY POSITION

 **THE HOSE AND THE DISCHARGE PORT WILL CONTAIN A SMALL AMOUNT OF REFRIGERANT UNDER PRESSURE. EXERCISE CARE WHEN REMOVING THIS HOSE AND OPENING THE VALVE V3.**

Figure 3-2 Setup Procedure for Purging



3.4 Push-Pull Operation

The PUSH PULL method is used to move a large amount of liquid refrigerant from the system being serviced to the recovery tank without passing it through the compressor. This method is only useful when more than 7 kg of liquid is known to be in the system and it can be easily isolated. **DO NOT ATTEMPT** the PUSH PULL process unless you are sure of the situation.

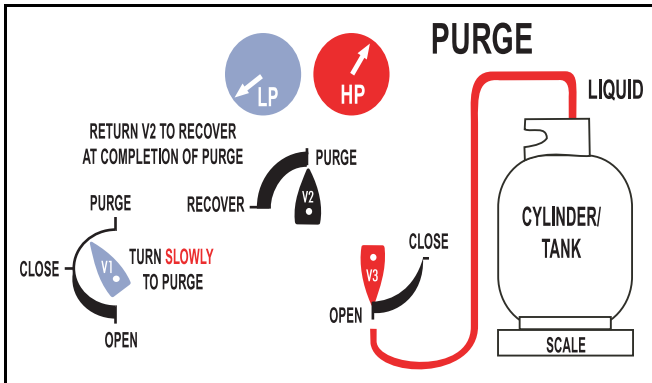
Connect the refrigerant hoses as shown in [Figure 3-3](#). The addition of a SIGHT GLASS in the line from the system being serviced to the recovery tank is an important aid to determine when the liquid has been transferred and vapor remains.

This process uses the PULL from the exhausted recovery tank and the Discharge PUSH from the Vortex to move the liquid refrigerant. Rates in excess of 7 kg per minute can be achieved by this procedure.

The SCALE is required in this process to ensure that the tank is not overfilled. The tank shutoff switch, if used, would stop the compressor but could not guarantee that additional refrigerant flow would cease because of the dynamics of the system, thus possibly overfilling the tank.

Figure 3-3 Setup Procedure for Push-Pull Method

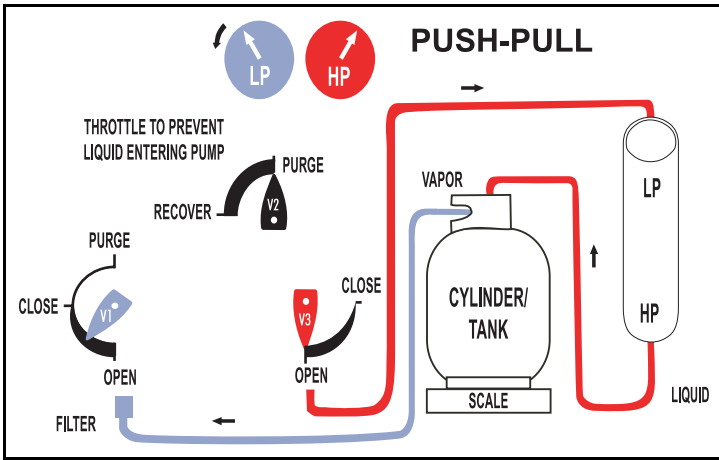

3.5 Cooling The Recovery Tank

The Vortex can be used to PRE-cool (or SUB-cool) the recovery tank if the head pressure is too high to complete the recovery process. This can occur when working with certain refrigerants with a high vapor pressure when the ambient temperature is high.

If the recovery process stalls out because of high head pressure, stop the Vortex, shut off the hose valves and reconfigure the setup as shown in [Figure 3-4](#). This can also be done before starting the recovery process, but it may have marginal long term effect.

NOTE: This will only work if there is at least 2 kg of liquid in the recovery tank to develop the necessary pressure differential required.

Figure 3-4 Setup Procedure for Sub-Cooling Method

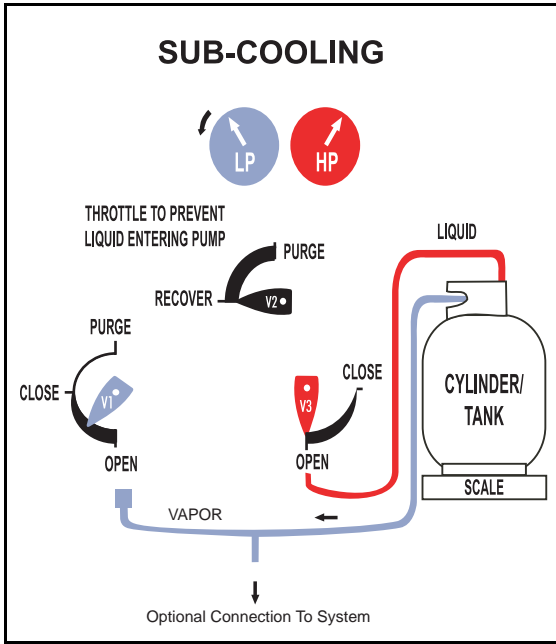

POWER ON the Vortex and ROTATE the DISCHARGE Valve (V3) to achieve a pressure differential of at least 6.8 bar between the LP Gauge and the HP Gauge. KEEP THE HP BELOW 37.4 bar on the HP Gauge to ensure that the HP Cutoff Switch will not actuate.

After several minutes of running, the tank will be cold. POWER OFF the Vortex and reconfigure the setup for NORMAL RECOVERY. Repeat as needed.

3.6 Special Operating Notes

During normal operation, when the High Pressure switch activates the machine will restart automatically when the head pressure drops below approximately 28.9 bar.

4.0 Maintenance

4.1 Introduction

Your Vortex will provide many seasons of reliable service providing it is properly maintained. The actual maintenance requirements are minimal but important.

Keep the unit clean by wiping it down with a damp cloth to remove dirt, oils, etc., prior to storage for the day. Standard household detergent or isopropyl alcohol may be used if the unit is particularly dirty — in all cases, exercise care to prevent liquids from entering the unit. Gasoline and other solvents are to be avoided as they can damage the Vortex’s plastic enclosure and they are hazardous.

Ensure that the Inlet and Discharge ports are protected in transit and storage — keep the inner diameter and the outer threads clear and clean. For best results, keep a FILTER permanently connected to the INLET port and change it regularly.

When performance falls off it is likely that the compressor seals require replacing. This is normal with use and may occur after a year or two, or more often depending upon the conditions that are prevalent during the recovery operations. Contact your Wholesaler for assistance in selecting the proper maintenance kit.

5.0 Troubleshooting

PROBLEM	CAUSE	ACTION
Unit will not start — Compressor does not start	<ul style="list-style-type: none"> • Power Cord not attached • No voltage at receptacle • Circuit breaker has opened • Discharge pressure too high, HP Switch has opened • Electronics failure in Motor 	<ul style="list-style-type: none"> • Attach Power Cord • Verify voltage at Job Site • Identify cause of breaker activation, rectify and reset • Reduce pressure and rotate V2 to Purge and back to Recovery • Factory service required

PROBLEM	CAUSE	ACTION
Compressor starts but cuts out within a few minutes — pressure indication on HP gauge is high	<ul style="list-style-type: none"> • V2 is in Purge position and HP switch activates • V3 not open and HP switch activates • Recovery tank valve not open • Blocked discharge hose • Air in system/tank 	<ul style="list-style-type: none"> • Rotate V2 to Recovery • Rotate V3 to open position • Open tank valve • Check & clear blockage • Bleed air from system/tank
Compressor stops intermittently	<ul style="list-style-type: none"> • Vapor pressure of refrigerant in tank is close to HP trip point • Thermal overload switch in compressor is activating 	<ul style="list-style-type: none"> • Reduce tank temperature • Reduce amount of liquid being pumped and let machine cool down before proceeding
Unit overheats	<p>Excessive head pressure due to:</p> <ul style="list-style-type: none"> • High ambient temperature • Restricted discharge hose • Air in recovery tank 	<ul style="list-style-type: none"> • Reduce tank temperature • Check & clear restriction • Bleed air from tank
Recovery process too slow	<ul style="list-style-type: none"> • Head pressure too high • System refrigerant iced up • Compressor seals are worn 	<ul style="list-style-type: none"> • Reduce tank temperature or change tanks • Throttle gauge manifold valves and V3 to reduce pressure differential between LP and HP gauges • Interrupt process to allow ice to dissipate • Rebuild compressor with service kit — check with wholesaler for assistance

6.0 Service

6.1 General



DO NOT CHANGE any of these components as the safety of the machine could be compromised. All service work must be performed at an INFICON approved facility in order to maintain the safety rating and the Warranty, if applicable.

Technical assistance and service information can be obtained through your local sales organization.

NOTE: Do not return a defective unit directly to the factory. Contact your Wholesaler or the factory for assistance.

The following Parts and Accessories for your Vortex are available through the same dealer from whom you purchased the unit:

Item	Part #
Thomas 500 Compressor, 230 V(dc)	708-408-P1
Bridge Rectifier, 25 A, 600 V	052-0206
Capacitor Assembly, 470 μ f, 400 V	600-1205-P2
Circuit breaker, 125/250 V, 4 A	062-0082
Cord set, IEC plug, 230 V	068-0399
On/Off Switch	065-0261
Manifold Assembly with extensions and fittings	708-403-P1
Gauge, High Pressure for Vortex Model 708-202-P2	708-402-P1
Gauge, Low Pressure for Vortex Model 708-202-P2	708-401-P1
Gauge, High Pressure for Vortex Model 708-202-P10	M1002V18B - 8252PA
Gauge, Low Pressure for Vortex Model 708-202-P10	M1002V18B - 8253PA
Pressure Switch, high pressure cutout	032-0055
Condenser Assembly with tubes	708-204-G1
Case Housing - right side	708-306-P1
Case Housing - left side	708-307-P1
Strap, shoulder	708-404-P1
Cap and strap, plastic with lead	070-1107
Handle, SS tube	708-311-P1

6.2 Electrical Schematic

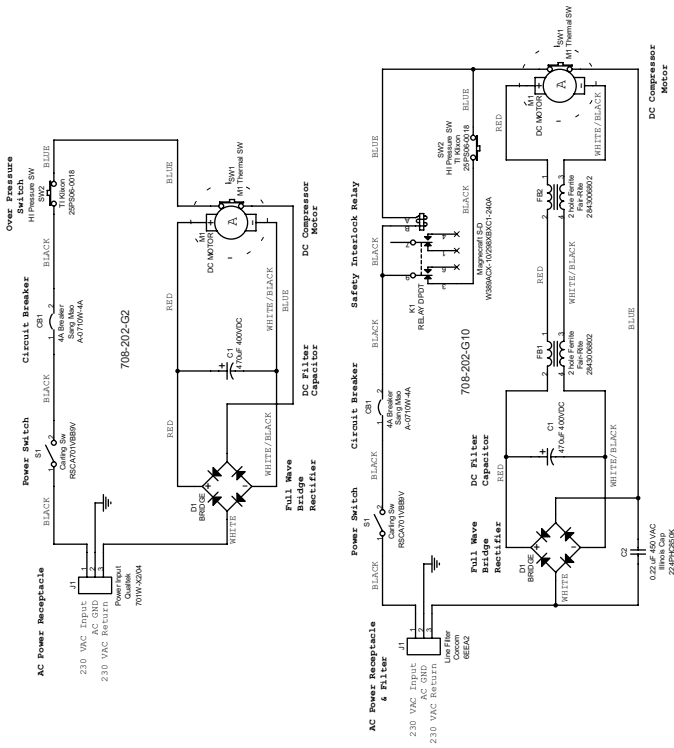

Figure 6-1 Electrical Schematic Diagram for 708-202-G2 & G10



TWO TECHNOLOGY PLACE
EAST SYRACUSE, NY 13057-9714 USA

Phone: +315.434.1100
Fax: +315.437-3803
Email: reachus@inficon.com
www.inficon.com

074-386-P1B