

Cold Cathode Gauge

MAG050
MAG060

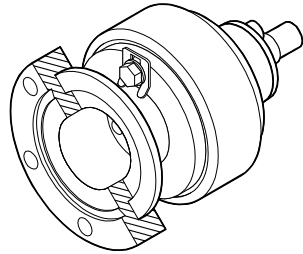

Operating Manual
Incl. EU Declaration of Conformity

tinb43e1 (2018-06)

Product Identification

In all communications with INFICON, please specify the information on the product nameplate. For convenient reference copy that information into the space provided below.

INFICON AG, LI-9496 Balzers

Model: _____
PN: _____
SN: _____

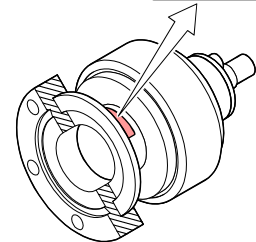

Validity

This document applies to products with part number

399-840	(MAG050, DN 25 ISO-KF)
399-841	(MAG050, DN 40 ISO-KF)
399-842	(MAG050, DN 40 CF-F)
399-845	(MAG060, DN 40 ISO-KF)
399-846	(MAG060, DN 40 CF-F)

The part number (PN) can be taken from the product nameplate.

If not indicated otherwise in the legends, the illustrations in this document correspond to the product with vacuum connection DN 40 ISO-KF. They apply to the products with other vacuum connections by analogy.

Intended Use

The above Cold Cathode Gauges have been designed for vacuum measurement in the pressure range of

MAG050:	$2 \times 10^{-9} \dots 5 \times 10^{-3}$ hPa mbar
MAG060:	$1 \times 10^{-10} \dots 5 \times 10^{-3}$ hPa mbar.

They are used together with a INFICON measurement and control unit of the type VGC083C.

Functional Principle

Over the whole measurement range, the measuring signal is output as logarithm of the pressure.

The MAG050 / MAG060 function with a cold cathode ionization measurement circuit (according to the inverted magnetron principle).

Safety

Symbols Used

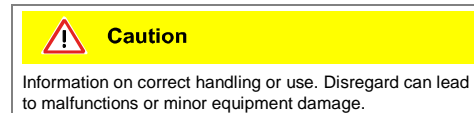
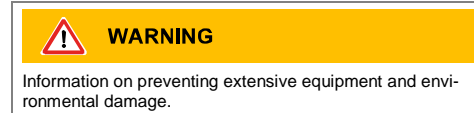

Personnel Qualification



All work described in this document may only be carried out by persons who have suitable technical training and the necessary experience or who have been instructed by the end-user of the product.

General Safety Instructions

- Adhere to the applicable regulations and take the necessary precautions for the process media used.
- Consider possible reactions between the materials (→ Technical Data) and the process media.
- Consider possible reactions (e.g. explosion) of the process media due to the heat generated by the product.
- Adhere to the applicable regulations and take the necessary precautions for all work you are going to do and consider the safety instructions in this document.
- Before beginning to work, find out whether any vacuum components are contaminated. Adhere to the relevant regulations and take the necessary precautions when handling contaminated parts.

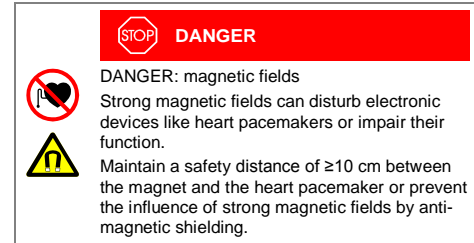

Communicate the safety instructions to all other users.

Responsibility and Warranty

INFICON assumes no liability and the warranty becomes null and void if the end-user or third parties

- disregard the information in this document
- use the product in a non-conforming manner
- make any kind of interventions (modifications, alterations, etc.) on the product
- use the product with accessories not listed in the corresponding product documentation.

The end-user assumes the responsibility in conjunction with the process media used.

Gauge failures due to contamination are not covered by the warranty.

Technical Data

Admissible temperatures	
Storage	-40 °C ... +80 °C
Operation	
MAG050	+5 °C ... +80 °C (with normal cable) +5 °C ... +150 °C (with high temperature cable)
MAG060	+5 °C ... +80 °C (with normal cable) +5 °C ... +250 °C (with high temperature cable)
Bakeout	
MAG050	+150 °C (without cable)
MAG060	+250 °C (without cable)
Relative humidity	max. 80% at temperatures up to +31 °C, decreasing to 50% at +40 °C
Use	indoors only altitude up to 2000 m NN

Measurement range (air, N ₂)	
MAG050	$2 \times 10^{-9} \dots 5 \times 10^{-3}$ hPa mbar
MAG060	$1 \times 10^{-10} \dots 5 \times 10^{-3}$ hPa mbar
Accuracy (N ₂ , typical)	30% of reading
Repeatability (typical)	5% of reading
Gas type dependence	→ Appendix

Protection type	IP 40
Overpressure	≤ 900 kPa (≤ 9 bar) for inert gases and temperatures < 55 °C only

Radiation resistance	
MAG050	-
MAG060	10^9 rad

Operating voltage (in measuring chamber)	≤ 3.3 kV
Operating current (in measuring chamber)	≤ 700 μ A

Electrical connection	
Connector	SHV
Type	coaxial cable

Cable length between gauge and measurement unit	
MAG050	max. 100 m (40 m if the lower limit of the measurement range is used → [1], Operating Manual VGC083C)
MAG060	max. 100 m (6 m if the lower limit of the measurement range is used, → [1], Operating Manual VGC083C)

Materials on the vacuum side	
Vacuum connection	stainless steel (1.4306)
Measuring chamber	
DN 25 ISO-KF	stainless steel (1.4104)
DN 40 ISO-KF / CF-F	stainless steel (1.4306)
Feedthrough isolation	ceramic (Al ₂ O ₃)
Internal seal	
MAG050	FPM
MAG060	Ag
Anode	Mo
Ignition aid	stainless steel (1.4310)
Internal volume	≈ 20 cm ³

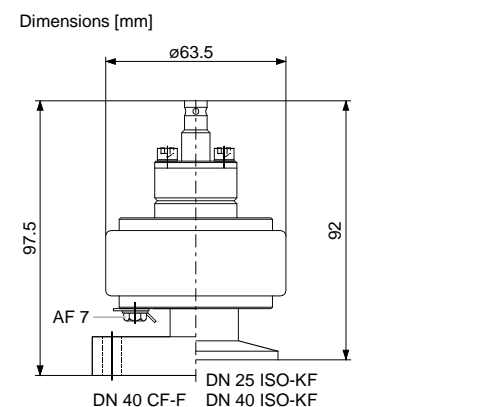

Weight	600 g (DN 25 ISO-KF, DN 40 ISO-KF) 850 g (DN 40 CF-F)
--------	--

Installation

Vacuum Connection

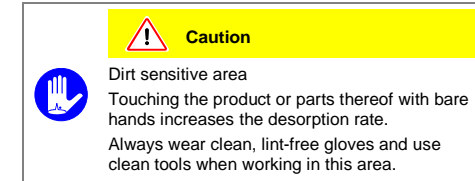
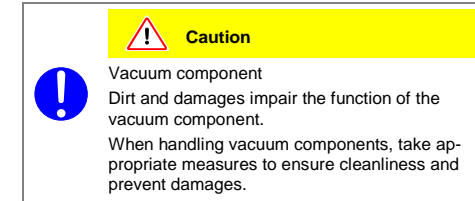
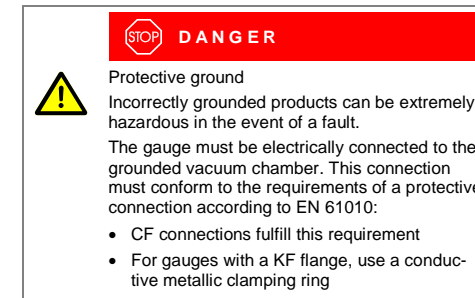
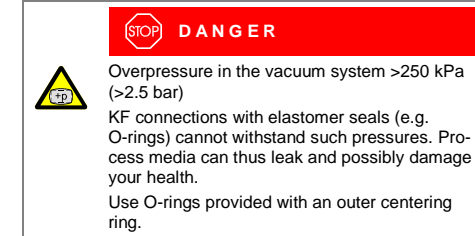
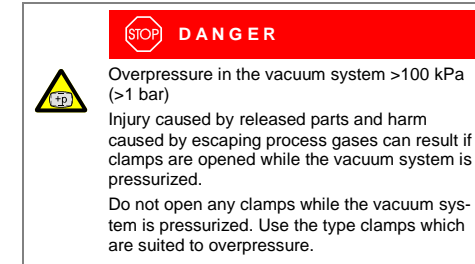

When CF vacuum connections are made, it can be advantageous to temporarily remove the magnet unit (→ Removing the Magnet Unit).

Mount the gauge so that no vibrations occur. Vibrations at the gauge cause a deviation of the measured values.

The gauge may be mounted in any orientation.

To keep condensates and particles from getting into the measuring chamber preferably choose a horizontal to upright position.

Remove the protective lid and connect the product to the vacuum system.

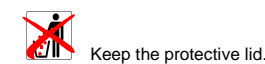

Removing the Magnet Unit

(CF vacuum connection only)

For reasons of tolerance, the same magnet unit has to be used again when reassembling the gauge.

Tools Required

- Allen wrench AF 1.5
- Open-end wrench AF 7

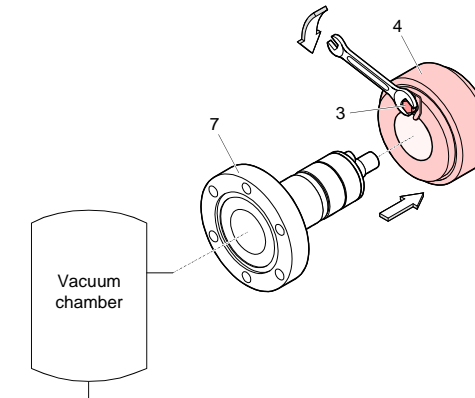

Procedure

- Unfasten the hex head screw (3) on the magnet unit (4) and remove the magnet unit.
The magnetic force and the tendency to tilt make it more difficult to separate the magnet unit and the measuring chamber (7).
- Make the vacuum connection between the gauge and the vacuum system.
- Mount the magnet unit and lock it with the hex head screw (3).

Electrical Connection

- Make sure the vacuum connection is properly made.
- The VGC083C control unit must be turned off before any work is performed on the gauge or sensor cable.

Connect the sensor cable to the gauge and to the INFICON measurement unit.

Operation

The gauge is ready for operation as soon as it has been connected.

Gas type Dependence

The measuring signal depends on the type of gas being measured. The value displayed is accurate for dry air, N₂, O₂ and CO. It can be mathematically converted for other gases. This can be done by entering the corresponding calibration factor on the INFICON measurement unit (→ Appendix).

Ignition Delay

When cold cathode measurement systems are activated, an ignition delay occurs. The delay time increases at low pressures and for clean, degassed gauges it is typically:

1×10^{-7} hPa mbar	≈ 0.1 minute
1×10^{-8} hPa mbar	≈ 1 minute
1×10^{-9} hPa mbar	≈ 5 minutes
1×10^{-10} hPa mbar	≈ 20 minutes (MAG060 only)

The ignition is a statistical process. Already a small amount of depositions on the inner surfaces can have a strong influence on it.

Contamination

Gauge failures due to contamination are not covered by the warranty.

Cold cathode gauges are subject to contamination. The degree of contamination and subsequently the accuracy of the measured value depend on:

- the pressure in the vacuum chamber
- contaminants inside the vacuum chamber (vapors, process particles, etc.)
- the measurement current.

To avoid extensive contamination switch the gauge on only at pressures of $< 10^{-2}$ hPa | mbar.

Contamination generally has the effect that the pressure indication is too low. If the contamination is severe, instability occurs. Contamination layers can peel off in the measuring chamber and cause short circuits.

Depending on the operating conditions, cleaning may therefore be necessary after a few days or after a few years.

Deinstallation

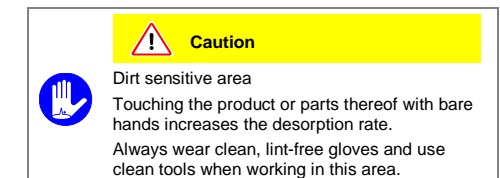
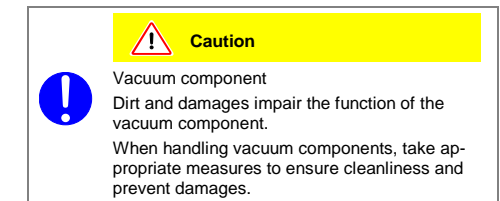
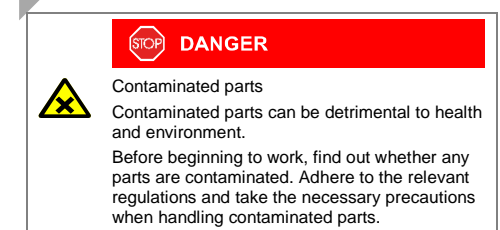

Procedure

- Turn off the VGC083C control unit.
- Vent the vacuum system and disconnect the sensor cable from the gauge.
- Remove gauge from the vacuum system and install the protective lid.

Maintenance

Sensor failures due to contamination are not covered by the warranty.

Cleaning the Gauge / Changing Parts

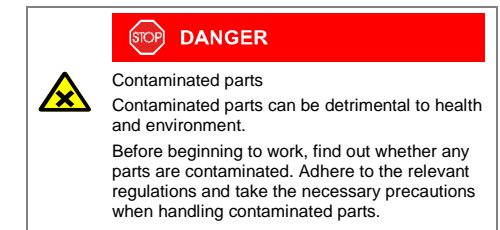

Caution

Vacuum component
Dirt and damages impair the function of the vacuum component.
When handling vacuum components, take appropriate measures to ensure cleanliness and prevent damages.

Caution

Dirt sensitive area
Touching the product or parts thereof with bare hands increases the desorption rate.
Always wear clean, lint-free gloves and use clean tools when working in this area.

Precondition

- Gauge removed from vacuum system

Tools required

- Allen wrench AF 3
- Open-end wrench AF 7
- Pliers for circlip
- Polishing cloth (grain 400) or Scotch-Brite
- Tweezers
- Mounting tool for ignition aid
- Cleaning alcohol

Disassembling the Gauge

(MAG050 → Figure 1, MAG060 → Figure 2)

Precondition

- Gauge removed from vacuum system

Procedure

- Unfasten the hex head screw (3) on the magnet unit (4) and remove the magnet unit.
The magnetic force and the tendency to tilt make it more difficult to separate the magnet unit and the measuring chamber (7).
For reasons of tolerance, the same magnet unit has to be used again when reassembling the gauge.
- Remove the circlip (5) and the pole insert (6) from the measuring chamber (7).
- Loosen the 2 hex socket screws (1a) and remove the coaxial connector (2a).
- Remove the 4 (or 2) hex socket screws (8) incl. the lock washers (8a) on the back of the measuring chamber (7).
- MAG050:** Carefully remove the following items in this order: pressure piece (9), complete anode (10), inner ring (11) and FPM seal (12).
MAG060: Carefully remove the following items in this order: pressure piece (9), washer (10b), complete anode (10), metal seal (11) and centering ring (12).

The parts can now be cleaned or replaced individually (→ next section).

Cleaning the Gauge

Procedure

DANGER

Adhere to the relevant regulations and take the necessary precautions when handling and disposing of cleaning agents.

Cleaning the measuring chamber and the pole insert:

- Clean the inside walls of the measuring chamber and the pole insert to a bright finish. Use a polishing cloth.

Caution

Sealing surfaces must only be worked concentrically.

- Rinse the measuring chamber and the pole insert with alcohol.

- Dry both.

Cleaning or replacing the anode (10):

- Remove the old ignition aid (10a), for example with tweezers.

- Rub the anode pin to a bright finish by means of a polishing cloth.

Caution

Do not bend the anode.
Do not carry out mechanical work on the ceramic part.

- Rinse the anode with cleaning alcohol.

- Dry the anode.

- Insert the new ignition aid (10a) into the mounting tool.

- Carefully press the anode (cleaned or new) centered and parallel to the tool axis into the ignition aid and insert it to a depth of ≈15 mm. The final position is established only after the anode is installed.

Assembling the Gauge

Procedure

- MAG050:** Insert the FPM seal (12) with the inner ring (11) centered into the measuring chamber (7). Sealing surface, seal and ceramic part must be clean (→ figure 1).
MAG060: Insert new metal seal (11) with the centering ring (12) centered into the measuring chamber (7). Sealing surface, seal and ceramic part must be clean (→ figure 2).
- Carefully insert the anode (10) incl. ignition aid (10a) into the measuring chamber.
- Place the pressure piece (9) incl. Washer (10b) on the measuring chamber (7) and tighten the screws (8) incl. lock washers (8a) uniformly until the stop position is reached.
- Position the ignition aid (10a): slide the mounting tool over the anode pin until the mechanical stop is reached.
- Remove particles in the measuring chamber (7) by blowing with dry nitrogen (while the flange of the measuring chamber is pointing downward).
- Slide the pole insert (6) into the measuring chamber (7) up to the mechanical stop (MAG050 → Figure 1, MAG060 → Figure 2).
- Place the circlip (5) snugly fitting on the pole insert.
Visually check that the anode pin is centered over the hole of the pole insert (tolerated eccentricity ≤0.5 mm).
- If possible perform a leak test (leak rate <math><10^{-9}</math> hPa l/s | mbar l/s).
- Place the coaxial connector (2a) on the measuring chamber and tighten both hex socket screws (1a).
- Mount the magnet unit (4) and lock it with the screw (3).

Figure 1: MAG050

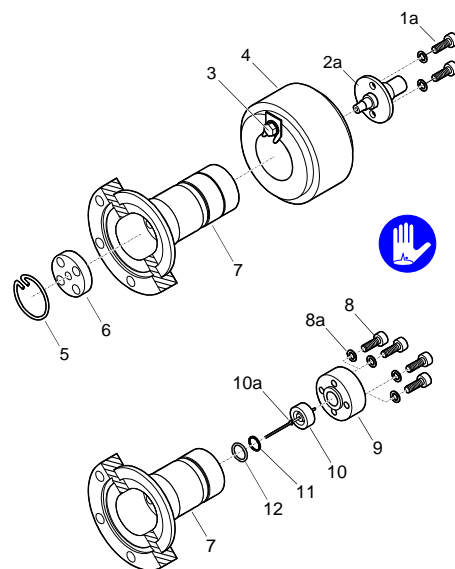
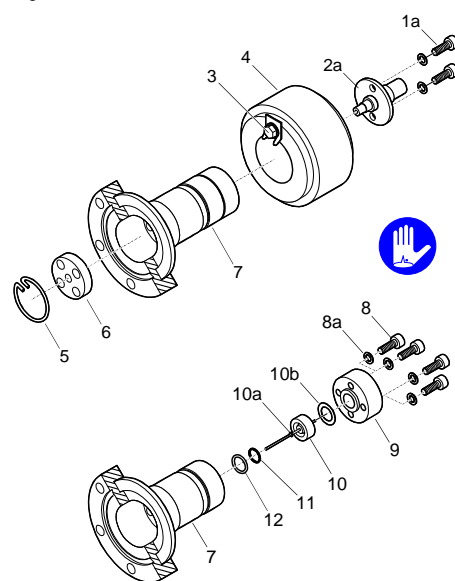

Figure 2: MAG060



Spare Parts / Accessories

When ordering spare parts, always indicate:

- all information on the nameplate
- description and ordering number according to spare parts list

MAG050	Position → figure 1	Ordering number
Maintenance kit		BN 846 239-T
Inner ring	(11)	
O-ring FPM, 3.69x1.78	(12)	
O-ring FPM, 10.82x1.78	(12)	
Ignition aid	(10a)	
Repair kit		BN 846 252-T
O-ring FPM, 10.82x1.78	(12)	
Anode complete	(10)	
Inner ring	(11)	
Ignition aid	(10a)	

¹⁾ O-ring not used.

MAG060	Position → figure 2	Ordering number
Maintenance kit		BN 846 241-T
Metal seal, HNV100 9x1.6	(11)	
Centering ring	(12)	
Ignition aid	(10a)	
Washer	(10b)	
Repair kit		BN 846 240-T
Anode complete	(10)	
Washer	(10b)	
Metal seal, HNV100 9x1.6	(11)	
Centering ring	(12)	
Ignition aid	(10a)	

Returning the Product

WARNING

Forwarding contaminated products
Contaminated products (e.g. radioactive, toxic, caustic or microbiological hazard) can be detrimental to health and environment.
Products returned to INFICON should preferably be free of harmful substances. Adhere to the forwarding regulations of all involved countries and forwarding companies and enclose a duly completed declaration of contamination (form under www.inficon.com).

Products that are not clearly declared as "free of harmful substances" are decontaminated at the expense of the customer.

Products not accompanied by a duly completed declaration of contamination are returned to the sender at his own expense.

Disposal

DANGER

Contaminated parts
Contaminated parts can be detrimental to health and environment.
Before beginning to work, find out whether any parts are contaminated. Adhere to the relevant regulations and take the necessary precautions when handling contaminated parts.

WARNING

Substances detrimental to the environment
Products or parts thereof (mechanical and electric components, operating fluids etc.) can be detrimental to the environment.
Dispose of such substances in accordance with the relevant local regulations.

Separating the components

After disassembling the product, separate its components according to the following criteria:

- Contaminated components
Contaminated components (radioactive, toxic, caustic, or biological hazard etc.) must be decontaminated in accordance with the relevant national regulations, separated according to their materials, and recycled.
- Other components
Such components must be separated according to their materials and recycled.

Appendix

Gas Type Dependence

Indicated pressure (gauge calibrated for air)

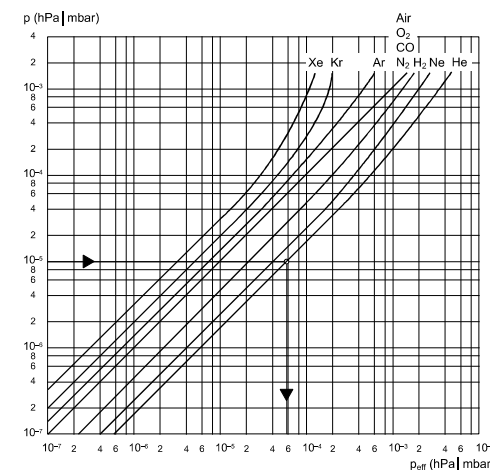

In the range below 10^{-5} hPa | mbar the pressure indication is linear. For gases other than air the pressure can be determined by means of a simple conversion formula:

$$p_{\text{eff}} = C \times \text{displayed pressure}$$

where	Gas type	C
	Air (N ₂ , O ₂ , CO)	1.0
	Xe	0.4
	Kr	0.5
	Ar	0.8
	H ₂	2.4
	Ne	4.1
	He	5.9

These conversion factors are average values.

A mixture of gases and vapors is often involved. In this case accurate determination is only possible with a partial pressure measuring instrument, e.g. an INFICON quadrupole mass spectrometer.

Literature

- [1] www.inficon.com
Operating Manual
VGC083C
tinb42e1
INFICON AG, LI-0496 Balzers, Liechtenstein

EU Declaration of Conformity

CE We, INFICON, hereby declare that the equipment mentioned below comply with the provisions of the following directives:

- 2014/30/EU, OJ L 96/79, 29.3.2014 (EMC Directive; directive relating to electromagnetic compatibility)
- 2011/65/EU, OJ L 174/88, 1.7.2011 (RoHS Directive; directive on the restriction of the use of certain hazardous substances in electrical and electronic equipment)

Products

Cold Cathode Gauge

MAG050
MAG060
(operation with VGC083C)

Standards

Harmonized and international/national standards and specifications:

- EN 61000-6-2:2005 (EMC: generic immunity standard)
- EN 61000-6-4:2007 + A1:2011 (EMC: generic emission standard)
- EN 61010-1:2010 (Safety requirements for electrical equipment for measurement, control and laboratory use)
- EN 61326-1:2013; Group 1, Class A (EMC requirements for electrical equipment for measurement, control and laboratory use)

Manufacturer / Signatures

INFICON AG, Alte Landstraße 6, LI-9496 Balzers

15 June 2018

15 June 2018

B. Andreano
Markus Truniger

Dr. Bernhard Andreau
Director Product Evolution

Markus Truniger
Product Manager