

EtherCAT[®]

for Bayard-Alpert Pirani Gauge

BPG402-SE

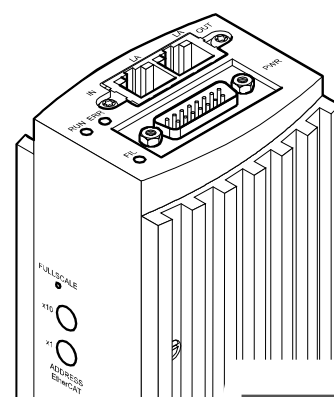

General Information

Caution

Data transmission errors
 Any attempt to simultaneously operate the gauge via the RS232C Serial Interface and EtherCAT interface may result in incorrect data and data transmission errors.
 Therefore, it is inadmissible to simultaneously operate the gauge via the RS232C Serial Interface and EtherCAT interface.

Intended Use

This Communication Protocol contains instructions for operating EtherCAT interfaces (slaves) together with a master.



For safety information, specifications and operation instructions of the vacuum gauges refer to the appropriate documents (→ [1], [2], [3]).

EtherCAT-Interface

The following description of the EtherCAT® interface is compliant to the EtherCAT specification of the EtherCAT Technology Group (ETG) and to the "EtherCAT® Semiconductor Device Profile".

This manual describes the functionality of a EtherCAT slave and supports

- ETG.5003.1 S (R) V1.1.0: Part 1 Common Device Profile (CDP) (→ [12]) and
- ETG.5003.2080 S (R) V1.3.0: Part 2080: Specific Device Profile (SDP): Vacuum Pressure Gauge (→ [13]).

For operating the gauge via EtherCAT, prior installation of the device specific ESI file is required on the bus master side. This file can be downloaded from our website.

Product Identification

In all communications with INFICON, please specify the information on the product nameplate. For convenient reference copy that information into the space provided below.

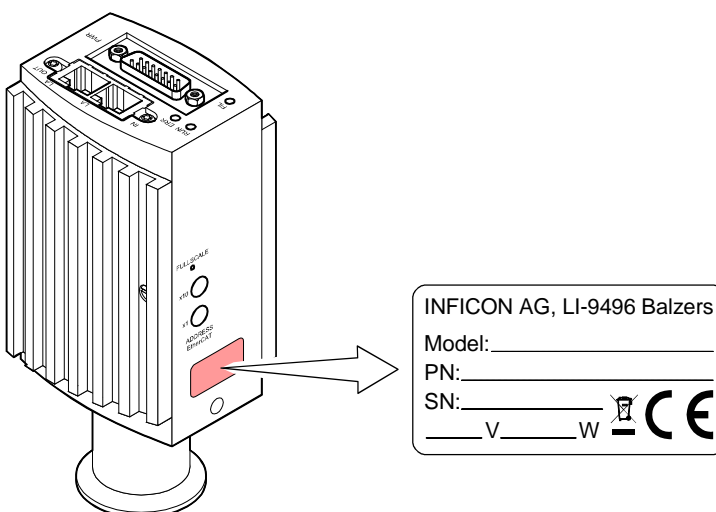

Validity

This document applies to BPG402 with EtherCAT interface.

353-596 (DN 25 ISO-KF)

353-597 (DN 40 CF-R)

This manual is based on firmware version 2.0.0.0.

If your unit does not work as described in this document, please check that it is equipped with the above firmware version (→  11, Index 100A).

The part number (PN) can be taken from the product nameplate.

If not indicated otherwise in the legends, the illustrations in this document correspond to the gauges with vacuum connection DN 25 ISO-KF. They apply to gauges with the other vacuum connection by analogy.

We reserve the right to make technical changes without prior notice.



Trademark

EtherCAT® Beckhoff Automation GmbH, Deutschland

Contents

General Information	2
Intended Use	2
EtherCAT–Interface	2
Product Identification	2
Validity	3
Trademark	3
1 Technical Data	6
2 Interface Connection	7
3 Operation	8
3.1 Introduction	8
3.2 Front and Side View	8
3.3 Indicators and Switches	9
3.3.1 <RUN> LED	9
3.3.2 <ERR> LED	9
3.3.3 <LA> LED (<IN> Port)	9
3.3.4 <LA> LED (<OUT> Port)	9
3.3.5 Device Address Switch	9
4 Object Structure	10
4.1 Object Dictionary structure	10
4.2 Communication Profile Objects (0x1000...0x1FFF)	11
4.2.1 Process Data Objects (PDO's)	11
4.3 Manufacturer-specific Profile Objects (0x2000...0x5FFF)	12
4.3.1 Manufacturer Configuration (Module 1)	13
4.3.2 Manufacturer Configuration (Module 2)	13
4.4 Input Area (0x6000...0x6FFF)	13
4.4.1 Input Common	13
4.4.2 Input Heat Transfer	13
4.4.3 Input Common	14
4.4.4 Input Hot Cathode Ion	14
4.4.5 Input Trip Point 1	15
4.4.6 Input Trip Point 2	15
4.5 Configuration Area (0x8000...0x8FFF)	15
4.5.1 Configuration Hot Cathode Ion	15
4.5.2 Configuration Trip Point 1	16
4.5.3 Configuration Trip Point 2	18
4.6 Information Area (0x9000...0x9FFF)	20
4.6.1 Information Heat Transfer	21
4.6.2 Information Common	21
4.6.3 Information Hot Cathode Ion	21
4.6.4 Information Trip Point 1/2	22
4.7 Device Area (0xF000...0xFFFF)	22
4.7.1 Semiconductor Device Profile	22
4.7.2 Module Profile List	22
4.7.3 Exceptions	22
4.7.4 Active Exception Status	22
4.7.5 Active Device Warning Details	23
4.7.6 Active Device Error Details	23
4.7.7 Active Global Device Warning Details	24
4.7.8 Active Global Device Error Details	24
4.7.9 Latched Device Warning Details	25
4.7.10 Latched Device Error Details	25
4.7.11 Latched Global Device Warning Details	25
4.7.12 Latched Global Device Error Details	26
4.7.13 Device Warning Mask	26
4.7.14 Device Error Mask	26
4.7.15 Global Device Warning Mask	26
4.7.16 Global Device Error Mask	27
4.8 Device specific Profile Objects	27
4.8.1 Communication Gauge	27
4.8.2 Trip Point Output All	27
4.8.3 Input Latch Local Timestamp	28
4.8.4 Configuration Device	28
4.8.5 Information Device	29
4.9 Command Objects	30
4.9.1 Command Degas ON / OFF	30

4.9.2	Command Emission ON / OFF	30
4.9.3	Device Reset Command	31
4.9.4	Exception Reset Command	32
4.9.5	Store Parameters Command	32
4.9.6	Calculate Checksum Command	33
4.9.7	Load Parameters Command	34
Appendix		35
A:	Overview Setting Trip Points	35
B:	Literature	37

For cross-references within this document, the symbol (→  [XY]) is used, for cross-references to other documents, listed under literature, the symbol (→  [Z]).

1 Technical Data



Further technical data → [1], [2], [3].

EtherCAT interface

Communication protocol	protocol specialized for EtherCAT
Communication standards	ETG.5003.1 S (R) V1.1.0: Part 1 Common Device Profile (CDP) ETG.5003.2080 S (R) V1.3.0: Part 2080 Specific Device Profile (SDP): Vacuum Pressure Gauge
Data rate	100 Mbps
Node address	Explicit Device Identification
Physical layer	100BASE-Tx (IEEE 802.3)
Digital functions	read pressure, select units (Torr, mbar, Pa) emission control, degas function monitor gauge status, filament status safe state allows definition of behavior in case of error detailed error and warning information
Analog functions	0 ... 10 V analog output pressure indication two setpoint relays A + B
Setpoint relays	2
Range	1×10^{-9} ... 100 mbar
Relay contact	NO, potential free
Hysteresis	10 % of reading
Contact rating	≤ 30 V / ≤ 0.5 A (dc)
EtherCAT connector	2 x RJ45, 8-pin (socket) <IN>: EtherCAT input <OUT> EtherCAT output
Cable	shielded, special Ethernet Patch Cable (CAT5e quality or higher)
Cable length	≤ 100 m
Process data	Fixed PDO mapping and configurable PDO mapping
Mailbox (CoE)	SDO requests, responses and information

Dimensions [mm]

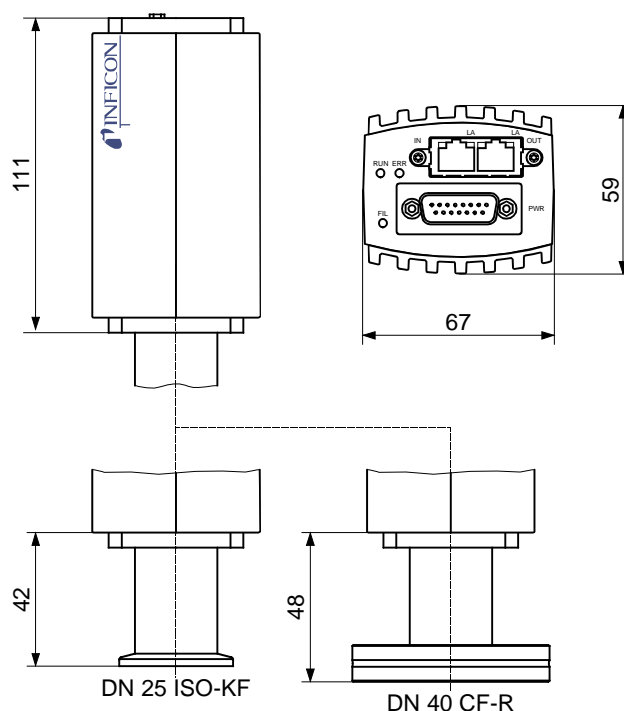

2 Interface Connection

Making an EtherCAT interface cable

For operating the BPG 402 gauge via EtherCAT, two interface cables conforming to the EtherCAT standard are required.
If no such cables are available, make two according to the following indications.

Cable type

Ethernet Patch Cable (CAT5e quality) with FCC68 connector.

Procedure

1 Pin assignment:

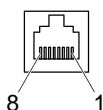

FCC68, 8-pin, male, soldering side

Pin	Signal	Description
1	TD+	Transmission Data +
2	TD-	Transmission Data -
3	RD+	Receive Data +
4	nu	not used
5	nu	not used
6	RD-	Receive Data -
7	nu	not used
8	nu	not used

Pin assignment of the D-sub 15-pin sensor connector according to the respective operating manual (→ [1], [2], [3]).

2 Plug the EtherCAT (and sensor) cables connector into the gauge: From the previous device the cable connected to OUT port has to be connected to the BPG402 <IN> port. And the cable from the BPG402 <OUT> port has to be connected to the next device's <IN> port.

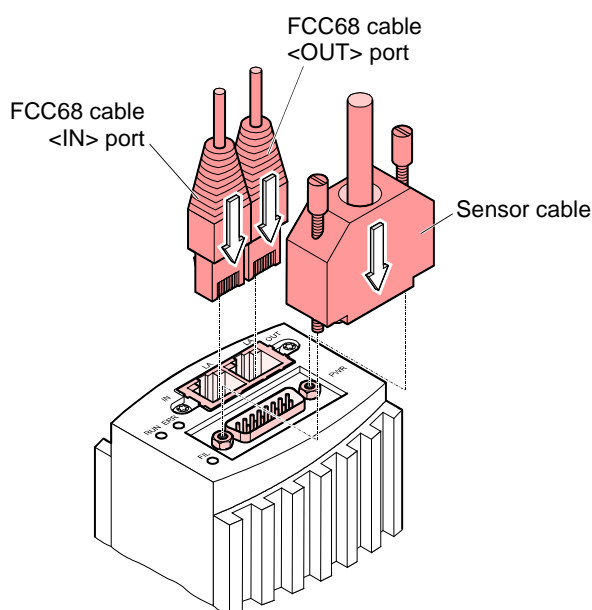

3 Operation

3.1 Introduction

Via the EtherCAT interface, the following and further data are exchanged in the standardized EtherCAT protocol:

- Pressure reading
- Pressure unit (Torr, mbar, Pa)
- Status and error messages
- Status of the switching functions
- Set Trip Point for switching functions



Caution



Data transmission errors

Any attempt to simultaneously operate the gauge via the RS232C Serial Interface and EtherCAT interface may result in incorrect data and data transmission errors.

Therefore, it is inadmissible to simultaneously operate the gauge via the RS232C Serial Interface and EtherCAT interface.

3.2 Front and Side View

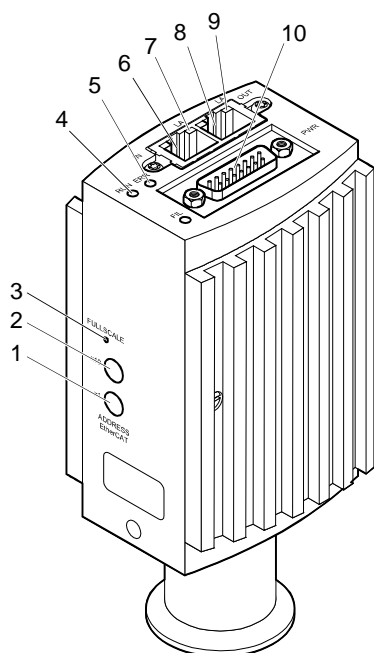

Position	Label	Function
1	x1	Address Switch x 1, hexadecimal
2	x10	Address Switch x 10, hexadecimal
3	FIL	Fullscale adjustment push button
4	RUN	EtherCAT Status LED
5	ERR	Error LED
6	IN	EtherCAT IN connector
7	LA	Link activity EtherCAT IN
8	OUT	EtherCAT OUT connector
9	LA	Link activity EtherCAT OUT
10	PWR	Sensor cable connector (Power, analog I/O, RS232C I/O and Relay contacts)

3.3 Indicators and Switches

3.3.1 <RUN> LED



Displays the operating status.

Color	LED State	Description
green	off	INIT (initialization status) or no power applied to device.
	blinking (200 ms on 200 ms off)	PREOP (pre-operational status).
	single flash (200 ms on 1000 ms off)	SAFEOP (safe-operational status). Communication of cyclic data transfer running. Input values available, output values written to the device but not updated on device output.
	on	OP (operational status).

3.3.2 <ERR> LED



Displays the error content.

Color	LED State	Description
red	off	No error or no power applied to device.
	blinking (200 ms on 200 ms off)	Error occurred (see error parameter).
	single flash (200 ms on 1000 ms off)	Slave device application has changed the EtherCAT state autonomously, due to local error (see error parameter).
	double flash (200 ms on 200 ms off 200 ms on 1000 ms off)	An application watchdog timeout has occurred. Sync Manager Watchdog timeout or communication timeout occurred.
	on	A critical communication or application controller error has occurred. Application controller is not responding any more (PDI Watchdog Timeout detected by ESC)

3.3.3 <LA> LED (<IN> Port)

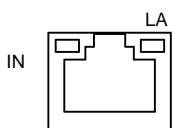

Displays the input status.

Color	LED State	Description
green	off	Port not connected or no power applied to device.
	blinking	Port connected and communication active.
	on	Port connected but no communication.

3.3.4 <LA> LED (<OUT> Port)

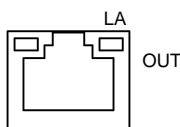

Displays the output status.

Color	LED State	Description
green	off	Port not connected or no power applied to device.
	blinking	Port connected and communication active.
	on	Port connected but no communication.

3.3.5 Device Address Switch

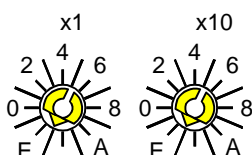

During device initialization, the device address switches are read by the device firmware. This device address is supported to the master as Explicit Device Identification.

Example: Value of the Explicit Device ID = 0xDD (dec 221):
 $0x10 * 0xD$ (dec 208) + $0x1 * 0xD$ (dec 13)

4 Object Structure

This chapter describes the CANopen over EtherCAT (CoE) Object Dictionary.

4.1 Object Dictionary structure

The objects in the CoE Object Dictionary can be accessed with SDO services, and many of the dictionary objects can be mapped for cyclic communication in PDOs. Each object is addressed using a 16-bit index and an 8-bit subindex.

The following table presents the overall layout of the standard Object Dictionary.

Index (hex.)	Object dictionary area	
1000 – 1FFF	Communication profile area	
2000 – 5FFF	Manufacturer-specific profile area	
6000 – 6FFF	Profile Specific Area	Input area
7000 – 7FFF		Output area
8000 – 8FFF		Configuration area
9000 – 9FFF		Information area
A000 – AFFF		Diagnosis area
B000 – BFFF		Service Transfer area
C000 – EFFF		Reserved area
F000 – FFFF		Device area

Explanations for the abbreviations in the columns of the tables are given below:

Abbr.	Description
Access	SDO read/write access <ul style="list-style-type: none"> RO: object can only be read by the SDO service RW: object can be both read and written by the SDO service
CoE	CAN application protocol over EtherCAT
Index	Object Index (hex.) (address of an object)
NV	Nonvolatile; attribute value is maintained through power cycles
Object	Abstract representation of a particular component within a device, which consists of data, parameters, and methods.
PDO	Process Data Object. Structure described by mapping parameters containing one or several process data entities.
PM	PDO mapping <ul style="list-style-type: none"> Rx: object can be mapped into an Rx PDO Tx : object can be mapped into a Tx PDO
RxPDO	Receive PDO. A Process Data Object received by an EtherCAT slave.
SDO	Service Data Objects. CoE asynchronous mailbox communications where all objects in the Object Dictionary can be read and written.
SI	Subindex (hex.) (sub-address of an object)
Type	Data Type <ul style="list-style-type: none"> BOOL, BIT = 1 bit. Boolean (0 = false, 1 = true) USINT, BYTE = 8 bit. Unsigned Byte UINT = 16 bit. Unsigned integer value UDINT = 32 bit. Unsigned integer value ULINT = 64 bit. Unsigned integer value REAL = 32 bit. Floating point V_STRING = 8xn bit. Visible string (1 byte for character)
TxPDO	Transmit PDO. A Process Data Object sent from an EtherCAT slave.

4.2 Communication Profile Objects (0x1000...0x1FFF)

The objects of the communication profile describe the basic EtherCAT properties of the BPG402 and are common to all EtherCAT slaves using the CoE communication protocol. The objects are described in following table:

Index	SI	Data Type	NV	Access	PM	Name
1000		UDINT		RO		Device Type 0x0000138B => 0x138B = dec 5003
1008		V_STRING		RO		Manufacturer Device name: BPG402
1009		V_STRING		RO		Manufacturer Hardware Version
100A		V_STRING		RO		Manufacturer Software Version
100B		V_STRING		RO		Manufacturer Bootloader Version
1010	0x01	UDINT		RW		Store Parameters Read: Bit 0 = 1: slave saves the backup entries when writing 0x1010:01 with 0x65766173 Bit 1-31 = 0 Write: With the value 0x65766173 the backup entries will be stored to non-volatile memory of the slave
1011	0x01	UDINT		RW		Restore Default Parameters Read: Bit 0 = 1: slave supports the restoring of backup entries with the default values when writing 0x1011:01 with 0x64616F6C Bit 1-31 = 0 Write: With the value 0x64616F6C the backup entries will be restored with the default values
1018				RO		Identity Object
	0x01	UDINT		RO		Vendor ID
	0x02	UDINT		RO		Product Code
	0x03	UDINT		RO		Revision Number
	0x04	UDINT		RO		Serial Number
10F8		ULINT		RO		Timestamp Object

4.2.1 Process Data Objects (PDO's)

The BPG402 consist of two vacuum pressure sensors. The characteristic of this combo device is that only one vacuum pressure sensor outputs an actual pressure value at one time. The other sensor is in overrange condition which means that the pressure is higher than the measurement range of the sensor or underrange condition which means that the pressure is lower than the measurement of the sensor. The 'Combination Gauge Active Value' outputs the pressure value from the active measuring sensor.

For each sensor module a default mapping is configured. The mapping for each sensor module has the same contents. For a compact cyclic data frame duplicated mappings can be deactivated..

Or to meet other requirements the TxPDO's 1A01 or 1A03 and the RxPDO 1601 are designated for user mapping. These PDO's do not have default values and can be set up by the PDO configuration.

RxPDO's

Index	SI	Data Type	NV	Access	PM	Name
1600		PM		RW		RxPDO Receive PDO Mapping,
1601		PM		RW		RxPDO Receive PDO Mapping, User Mapping

TxPDO's

Index	SI	Data Type	NV	Access	PM	Name
1A00		PM		RW		TxPDO Transmit PDO Mapping
	0x01	BIT				Reading Valid Combination Gauge
	0x02	BIT				Overrange Exceeded Combination Gauge
	0x03	BIT				Underrange Exceeded Combination Gauge
	0x04	BIT				Padding Bits 1 (5 bit)
	0x05	REAL				Sensor Value Combination Gauge
	0x06	UINT				Active Sensor Number Combination Gauge
1A01		PM		RW		TxPDO Transmit PDO Mapping, User Mapping
1A02		PM		RW		TxPDO Transmit PDO Mapping
	0x01	BIT				Reading Valid Combination Gauge
	0x02	BIT				Overrange Exceeded Combination Gauge
	0x03	BIT				Underrange Exceeded Combination Gauge
	0x04	BIT				Padding Bits 1 (5 bit)
	0x05	REAL				Sensor Value Combination Gauge
	0x06	UINT				Active Sensor Number Combination Gauge
1A03		PM		RW		TxPDO Transmit PDO Mapping, User Mapping
1BFE		PM		RW		Transmit PDO Mapping
	0x01	BYTE				Active Exception Status
	0x02	UDINT				Trip Point Output All Instance
1BFF		PM		RW		TxPDO Transmit PDO Mapping Device, User Mapping
1C00	0x01 0x02 0x03 0x04	BYTE		RW		Sync Manager Type
1C12 / 1C13	0x01 0x02 0x03 0x04	UINT		RW		Sync Manager PDO Assignment
1C32 / 1C33	0x01 - 0x20			RW		Sync Manager Parameter

4.3 Manufacturer-specific Profile Objects (0x2000...0x5FFF)

The manufacturer-specific profile objects contain the manufacturer's model number and device configuration data, status and diagnostic data. The objects are described in the following tables.

4.3.1 Manufacturer Configuration (Module 1)

Index	SI	Data Type	NV	Access	PM	Name
4000	0x02	REAL		RW		Safe Value

Subindex 0x02

Safe Value: The value to be used for Safe State = Safe Value.

4.3.2 Manufacturer Configuration (Module 2)

Index	SI	Data Type	NV	Access	PM	Name
4010	0x02	REAL		RW		Safe Value

Subindex 0x02

Safe Value: The value to be used for Safe State = Safe Value.

4.4 Input Area (0x6000...0x6FFF)

4.4.1 Input Common

Index	SI	Data Type	NV	Access	PM	Name
6000	0x0E	BOOL		RO	tx	TxPdoState
	0x11	REAL		RO	tx	Sensor Value

Subindex 0x0E

Is set if the device is not in Safe State (value (I 0x6nn0, SI 0x11) = valid)

TxPdoState	
0	Invalid
1	Valid

Subindex 0x11

The corrected, converted, calibrated final analog input value of the sensor.

4.4.2 Input Heat Transfer

Index	SI	Data Type	NV	Access	PM	Name
6003	0x01	BOOL		RO	tx	Reading Valid
	0x02	BOOL		RO	tx	Overrange Exceeded
	0x03	BOOL		RO	tx	Underrange Exceeded

Subindex 0x01

Indicates whether the Value parameter contains a valid value within the specified accuracy or not.

Reading Valid	
0	Invalid
1	Valid

Subindex 0x02

Indicates whether the Value parameter contains a value in over range.

Reading Valid	
0	No Overrange Exceeded
1	Overrange Exceeded

Subindex 0x03

Indicates whether the Value parameter contains a value in under range.

Reading Valid	
0	No Underrange Exceeded
1	Underrange Exceeded

4.4.3 Input Common

Index	SI	DataType	NV	Access	PM	Name
6010	0x0E	BOOL		RO	tx	TxPdoState
	0x11	REAL		RO	tx	Sensor Value

Subindex 0x0E

Is set if the device is not in Safe State (value (I 0x6010, SI 0x11) = valid)

TxPdoState	
0	Invalid
1	Valid

Subindex 0x11

The corrected, converted, calibrated final analog input value of the sensor.

4.4.4 Input Hot Cathod Ion

Index	SI	DataType	NV	Access	PM	Name
6015	0x01	BOOL		RO	tx	Reading Valid
	0x02	BOOL		RO	tx	Overrange Exceeded
	0x03	BOOL		RO	tx	Underrange Exceeded
	0x05	BOOL		RO	tx	Emission Status Off/On
	0x06	BOOL		RO	tx	Degas Status Off/On

Subindex 0x01

Indicates whether the Value parameter contains a valid value within the specified accuracy or not.

Reading Valid	
0	Invalid
1	Valid

Subindex 0x02

Indicates whether the Value parameter contains a value in over range.

Reading Valid	
0	No Overrange Exceeded
1	Overrange Exceeded

Subindex 0x03

Indicates whether the Value parameter contains a value in under range.

Reading Valid	
0	No Underrange Exceeded
1	Underrange Exceeded

Subindex 0x05

Emission Status Off/On	
0	OFF
1	ON

Subindex 0x06

Degas Status Off/On	
0	OFF
1	ON

4.4.5 Input Trip Point 1

Index	SI	Data Type	NV	Access	PM	Name
600E	0x01	BOOL		RO	tx	Status High Trip
	0x02	BOOL		RO	tx	Status Low Trip

Subindex 0x01

Status High Trip	
0	High Trip not assert
1	High Trip assert

Subindex 0x02

Status Low Trip	
0	Low Trip not assert
1	Low Trip assert

4.4.6 Input Trip Point 2

Index	SI	Data Type	NV	Access	PM	Name
600F	0x01	BOOL		RO	tx	Status High Trip
	0x02	BOOL		RO	tx	Status Low Trip

Subindex 0x01

Status High Trip	
0	High Trip not assert
1	High Trip assert

Subindex 0x02

Status Low Trip	
0	Low Trip not assert
1	Low Trip assert

4.5 Configuration Area (0x8000...0x8FFF)

4.5.1 Configuration Hot Cathode Ion

Index	SI	Data Type	NV	Access	PM	Name
8015	0x01	BOOL	x	RW		Filament User Mode
	0x02	BOOL	x	RW		Emission User Mode
	0x11	BYTE	x	RW		Active Filament
	0x13	REAL	x	RW		Emission Current

Subindex 0x01

Defines whether the filament selection is static as defined by "Active Filament" = manual mode or the active filament is changed always when the filament is switched on = automatic mode

Filament User Mode	
0	Automatic
1	Manual

Subindex 0x02

Defines whether the emission is switched on automatically by a different sensor (automatic) or manually by the user (manual)

Emission User Mode	
0	Automatic
1	Manual

Subindex 0x11

Active Sensor filament

Active Filament	
Bit 0	Filament 1 is on if Bit is set
Bit 1	Filament 2 is on if Bit is set
Bit 1...7	0

Subindex 0x13

Emission current in milliamps
It is not possible to change the value.

4.5.2 Configuration Trip Point 1

If "High Trip Source Index" is 0x800E1100 or 0x800F1100 the High Trip Point is equal with the value referenced in "High Trip Point Limit".

The value defined in "High Trip Point Limit" is compared with the pressure value referenced by the "Source Index" parameter.

If "Low Trip Source Index" is 0x800E1400 or 0x800F1400 the Low Trip Point is equal with the value referenced in "Low Trip Point Limit".

The value defined in "Low Trip Point Limit" is compared with the pressure value referenced by the "Source Index" parameter.

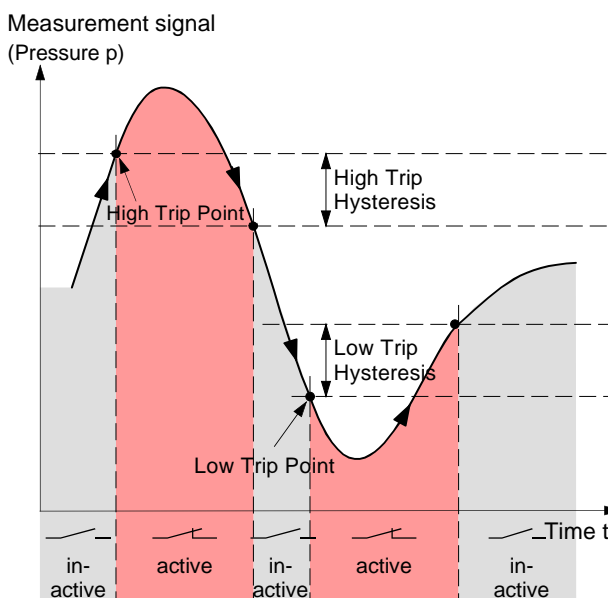

Index	SI	Data Type	NV	Access	PM	Name
800E	0x01	BOOL	x	RW		High Trip Enable
	0x02	BOOL	x	RW		Low Trip Enable
	0x04	BOOL	x	RW		Override Enable
	0x05	BOOL	x	RW		Override High Trip
	0x06	BOOL	x	RW		Override Low Trip
	0x11	REAL	x	RW		High Trip Point Limit
	0x12	UDINT	x	RW		High Trip Source Index
	0x13	REAL	X	RW		Percentage High Trip Source
	0x14	REAL	x	RW		Low Trip Point Limit
	0x15	UDINT	x	RW		Low Trip Source Index
	0x16	REAL	x	RW		Percentage Low Trip Source
	0x17	REAL	x	RW		High Trip Hysteresis
	0x18	REAL	x	RW		Low Trip Hysteresis
	0x1A	UDINT	x	RW		Source Index

Subindex 0x01

High Trip Point Enable	
0	Disable
1	Enable

Subindex 0x02

Low Trip Point Enable	
0	Disable
1	Enable

Subindex 0x04

Override Enable	
0	Disable
1	Enable

Subindex 0x05

Override High Trip	
0	Disable
1	Enable

Subindex 0x06

Override Low Trip	
0	Disable
1	Enable

Subindex 0x11

High Trip Point Limit: High limit to trigger trip point condition if Input Value (I 0x900E, SI 0x01) is above this limit.

Subindex 0x12

Object index of High Trip Point Value source. Index of High Trip Point Limit (I 0x800E, SI 0x11)

Bit 16...31: Index
 Bit 08...15: Subindex
 Bit 00...07: reserved

It is only possible to reference to "High Trip Point Limit" (I 0x800E, SI 0x11).

Subindex 0x13

Percentage of Value referenced by High Trip Source Index in [%]. If High Trip Source Index is I 0x800E, SI 0x11 this parameter is not used.

Subindex 0x14

Low Trip Point Limit: Low limit to trigger trip point condition if Input Value (I 0x900E, SI 0x01) is below this limit.

Subindex 0x15

Object index of Low Trip Point Value source. Index of Low Trip Point Limit (I 0x800E, SI 0x14)

Bit 16...31: Index
 Bit 08...15: Subindex
 Bit 00...07: reserved

It is only possible to reference to "Low Trip Point Limit" (I 0x800E, SI 0x14).

Subindex 0x16

Percentage of Value referenced by Low Trip Source Index in [%]. If Low Trip Source Index is I 0x800E, SI 0x14 this parameter is not used.

Subindex 0x17

High Trip Hysteresis: Hysteresis value for High Trip Point.

Subindex 0x18

Low Trip Hysteresis: Hysteresis value for Low Trip Point.

Subindex 0x1A

Object index of active source of (I 0x900E SI 0x01) Input Value.

Source Index	
Bit 16...31	Index
Bit 08...15	Subindex
Bit 00...07	Reserved

4.5.3 Configuration Trip Point 2

Index	SI	Data Type	NV	Access	PM	Name
800F	0x01	BOOL	x	RW		High Trip Enable
	0x02	BOOL	x	RW		Low Trip Enable
	0x04	BOOL	x	RW		Override Enable
	0x05	BOOL	x	RW		Override High Trip
	0x06	BOOL	x	RW		Override Low Trip
	0x11	REAL	x	RW		High Trip Point Limit
	0x12	UDINT	x	RW		High Trip Source Index
	0x13	REAL	X	RW		Percentage High Trip Source
	0x14	REAL	x	RW		Low Trip Point Limit
	0x15	UDINT	x	RW		Low Trip Source Index
	0x16	REAL	x	RW		Percentage Low Trip Source
	0x17	REAL	x	RW		High Trip Hysteresis
	0x18	REAL	x	RW		Low Trip Hysteresis
	0x1A	UDINT	x	RW		Source Index

Subindex 0x01

High Trip Point Enable	
0	Disable
1	Enable

Subindex 0x02

Low Trip Point Enable	
0	Disable
1	Enable

Subindex 0x04

Override Enable	
0	Disable
1	Enable

Subindex 0x05

Override High Trip	
0	Disable
1	Enable

Subindex 0x06

Override Low Trip	
0	Disable
1	Enable

Subindex 0x11

High Trip Point limit: High limit to trigger trip point condition if Input Value (I 0x900F, SI 0x01) is above this limit.

- Subindex 0x12 Object index of High Trip Point Value source. Index of High Trip Point Limit (I 0x800F, SI 0x11)
- Bit 16...31: Index
 Bit 08...15: Subindex
 Bit 00...07: reserved
- It is only possible to reference to "High Trip Point Limit" (I 0x800F, SI 0x11).
- Subindex 0x13 Percentage of Value referenced by High Trip Source Index in [%]. If High Trip Source Index is I 0x800F, SI 0x11 this parameter is not used.
- Subindex 0x14 Low Trip Point Limit: Low limit to trigger trip point condition if Input Value (I 0x900F, SI 0x01) is below this limit.
- Subindex 0x15 Object index of Low Trip Point Value source. Index of Low Trip Point Limit (I 0x800F, SI 0x14).
- Bit 16...31: Index
 Bit 08...15: Subindex
 Bit 00...07: reserved
- It is only possible to reference to "Low Trip Point Limit" (I 0x800F, SI 0x14).
- Subindex 0x16 Percentage of Value referenced by Low Trip Source Index in [%]. If Low Trip Source Index is I 0x800F, SI 0x14 this parameter is not used.
- Subindex 0x17 High Trip Hysteresis: Hysteresis value for High Trip Point.
- Subindex 0x18 Low Trip Hysteresis: Hysteresis value for Low Trip Point.
- Subindex 0x1A Object index of active source of (I 0x900F SI 0x01) Input Value.

Source Index	
Bit 16...31	Index
Bit 08...15	Subindex
Bit 00...07	Reserved

4.6 Information Area (0x9000...0x9FFF)

The Information Data object defines the input process data.

Highest / lowest measurement value

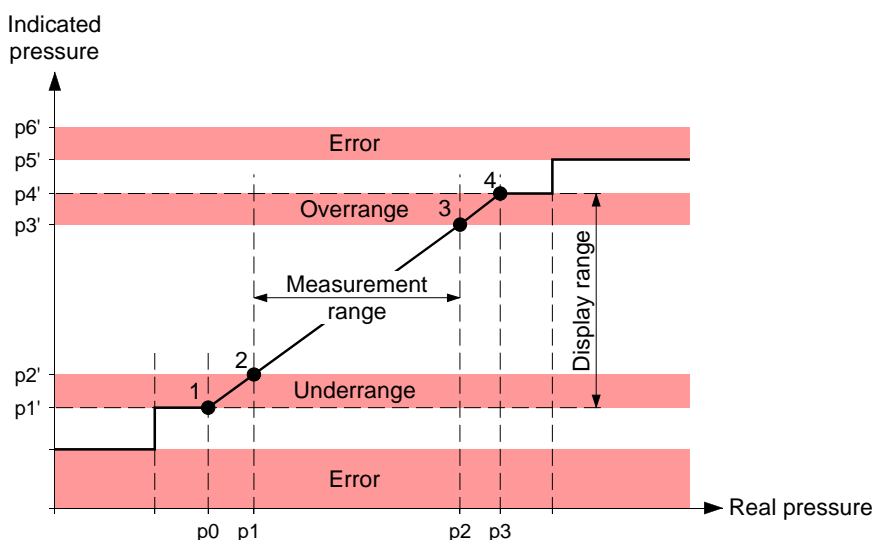

The "measurement range" is the range between minimum and maximum pressure, where the reading of the gauge is within the specified measurement uncertainty limits.

The "valid measurement information range" (display range) is the complete pressure range where the gauge gives an indication (measurement signal). The valid measurement information range (display range) consists of underrange, measurement range and overrange.

According to these definitions, 4 points are defined:

- 1 Lowest informational measurement value
- 2 Lowest precision measurement value
- 3 Highest precision measurement value
- 4 Highest informational measurement value

Index	SI	Data Type	NV	Access	PM	Name
9000	0x02	REAL	x	RO		Highest Informational Measurement Value
	0x03	REAL	x	RO		Highest Precision Measurement Value
	0x04	REAL	x	RO		Lowest Precision Measurement Value
	0x05	REAL	x	RO		Lowest Informational Measurement Value

Subindex 0x02

Highest Informational Measurement Value: Highest value that the gauge can measure without a specified accuracy.

Subindex 0x03

Highest Precision Measurement Value: Highest valid value at which the gauge is specified with an accuracy value. Above that value, the parameter Reading Valid is set to invalid.

Subindex 0x04

Lowest Precision Measurement Value: Lowest valid value at which the gauge is specified with an accuracy value. Below that value, the parameter Reading Valid is set to invalid.

Subindex 0x05

Lowest value the gauge can measure without a specified accuracy.

4.6.1 Information Heat Transfer

Index	SI	Data Type	NV	Access	PM	Name
9003	0x01	UINT		RO		Sensor Warning
	0x02	UINT		RO		Sensor Error

Subindex 0x01

Sensor Warnings	
Bit 0	0
Bit 1	Electronics Warning
Bit 2...15	0

Subindex 0x02

Sensor Errors	
Bit 0	0
Bit 1	Electronics Failure
Bit 2...15	0

4.6.2 Information Common

Index	SI	Data Type	NV	Access	PM	Name
9010	0x02	REAL	x	RO		Highest Informational Measurement Value
	0x03	REAL	x	RO		Highest Precision Measurement Value
	0x04	REAL	x	RO		Lowest Precision Measurement Value
	0x05	REAL	x	RO		Lowest Informational Measurement Value

Subindex 0x02

Highest Informational Measurement Value: Highest value that the gauge can measure without a specified accuracy.

Subindex 0x03

Highest Precision Measurement Value: Highest valid value at which the gauge is specified with an accuracy value. Above that value, the parameter Reading Valid is set to invalid.

Subindex 0x04

Lowest Precision Measurement Value: Lowest valid value at which the gauge is specified with an accuracy value. Below that value, the parameter Reading Valid is set to invalid.

Subindex 0x05

Lowest value the gauge can measure without a specified accuracy.

4.6.3 Information Hot Cathode Ion

Index	SI	Data Type	NV	Access	PM	Name
9015	0x01	UINT		RO		Sensor Warning
	0x02	UINT		RO		Sensor Error

Subindex 0x01

Sensor Warnings	
Bit 0	Sensor Filament 1 Warning
Bit 1	Sensor Filament 2 Warning
Bit 2...8	0
Bit 9	Electronics Warning
Bit 10	0
Bit 11	Pressure too high for Degass
Bit 12...15	0

Subindex 0x02

Sensor Errors	
Bit 0	Sensor Filament 1 Error
Bit 1	Sensor Filament 2 Error
Bit 2...8	0
Bit 9	Electronics Failure
Bit 10	0
Bit 11	Overpressure Emission OFF
Bit 12...15	0

4.6.4 Information Trip Point 1/2

Index	SI	DataType	NV	Access	PM	Name
900E	0x01	REAL		RO		Input Value Trip Point 1
900F	0x01	REAL		RO		Input Value Trip Point 2

Subindex 0x01 (900E)

Input Value Trip Point 1: Trip Point Input value as referenced by Source Index (I 0x800E, SI 0x0E).

Subindex 0x01 (900F)

Input Value Trip Point 2: 0 Trip Point Input value as referenced by Source Index (I 0x800F, SI 0x0E).

4.7 Device Area (0xF000...0xFFFF)

4.7.1 Semiconductor Device Profile

Index	SI	DataType	NV	Access	PM	Name
F000	0x01	UINT		RO		Index Distance
	0x02	UINT		RO		Maximum Number of Modules

Subindex 0x01

Index Distance: Index offset between PDO entries of two consecutive modules (for ETG.5003 = 0x10), e.g. 0x6000, 0x6010.

Subindex 0x02

Maximum Number of Modules: For the BPG402 this value always is 2.

4.7.2 Module Profile List

Index	SI	DataType	NV	Access	PM	Name
F010	0x01	UDINT		RO		Profile Number
	0x02	UDINT		RO		Profile Number

Subindex 0x01

Each sub-index lists the profile-number of the corresponding module. (Module 1)

Subindex 0x02

Each sub-index lists the profile-number of the corresponding module. (Module 2)

4.7.3 Exceptions

4.7.4 Active Exception Status

Index	SI	DataType	NV	Access	PM	Name
F380		USINT		RO	tx	ActiveException Status

Active Exception Status

Active Exception Status	
Bit 0	Device Warning
Bit 1	Manufacturer Warning
Bit 2	Device Error
Bit 3	Manufacturer Error
Bit 4...7	0

4.7.5 Active Device Warning Details

The "active device warning details" parameter describes the warning state of the complete device.

Index	SI	Data Type	NV	Access	PM	Name
F381	0x01	UDINT		RO	tx	Active Device Warning Details
	0x02	UDINT		RO	tx	Active Device Warning Details
F382	0x01	UDINT		RO	tx	Active Manufacturer Warning Details
	0x02	UDINT		RO	tx	Active Manufacturer Warning Details

Subindex 0x01 (F381)

Active Device Warning Details (Index F381, Module 1)	
Bit 0	0
Bit 1	Electronics warning
Bit 2...31	0

Subindex 0x02 (F381)

Active Device Warning Details (Index F381, Module 2)	
Bit 0	0
Bit 1	Electronics warning
Bit 2...31	0

Subindex 0x01 (F382)

Active Manufacturer Warning Details (Index F382, Module 1)	
Bit 0...31	0

Subindex 0x02 (F382)

Active Manufacturer Warning Details (Index F382, Module 2)	
Bit 0...31	0

4.7.6 Active Device Error Details

The "active device error details" parameter describes the error state of the complete device.

Index	SI	Data Type	NV	Access	PM	Name
F383	0x01	UDINT		RO	tx	Active Device Error Details
	0x02	UDINT		RO	tx	Active Device Error Details
F384	0x01	UDINT		RO	tx	Active Manufacturer Error Details
	0x02	UDINT		RO	tx	Active Manufacturer Error Details

Subindex 0x01 (F383)

Active Device Error Details (Index F383, Module 1)	
Bit 0	0
Bit 1	Electronics failure
Bit 2...31	0

Subindex 0x02 (F383)

Active Device Error Details (Index F383, Module 2)	
Bit 0	0
Bit 1	Electronics failure
Bit 2...31	0

Subindex 0x01 (F384)

Active Manufacturer Error Details (Index F384, Module 1)	
Bit 0...31	0

Subindex 0x02 (F384)

Active Manufacturer Error Details (Index F384, Module 2)	
Bit 0...31	0

4.7.7 Active Global Device Warning Details

The "active global device warning details" parameter describes the warning state of the complete device.

Index	SI	Data Type	NV	Access	PM	Name
F385	0x01	UDINT		RO	tx	Active Global Device Warning Details
F386	0x01	UDINT		RO	tx	Active Global Manufacturer Warning Details

Subindex 0x01 (F385)

Active Global Device Warning Details (Index F385)	
Bit 0...2	0
Bit 3	EEPROM exception
Bit 4...31	0

Subindex 0x01 (F386)

Active Global Manufacturer Warning Details (Index F386)	
Bit 0	Internal Communication Exception (between EtherCAT-Protocol and Device-Application)
Bit 1...31	0

4.7.8 Active Global Device Error Details

The "active device error details" parameter describes the error state of the complete device.

Index	SI	Data Type	NV	Access	PM	Name
F387	0x01	UDINT		RO	tx	Active Global Device Error Details
F388	0x01	UDINT		RO	tx	Active Global Manufacturer Error Details

Subindex 0x01 (F387)

Active Device Error Details Device (Index F387)	
Bit 0	0
Bit 1	uP exception
Bit 2...31	0

Subindex 0x01 (F388)

Active Manufacturer Error Details (Index F388)	
Bit 0	Internal Communication Exception (between EtherCAT-Protocol and Device-Application)
Bit 1	Wrong software version used in base device
Bit 2	Wrong sensor type detected
Bit 3...31	0

4.7.9 Latched Device Warning Details

Index	SI	Data Type	NV	Access	PM	Name
F390		USINT		RO	tx	Latched Exceptions Status
F391	0x01	UDINT		RO	tx	Latched Device Warning Details
	0x02	UDINT		RO	tx	Latched Device Warning Details
F392	0x01	UDINT		RO	tx	Latched Manufacturer Warning Details
	0x02	UDINT		RO	tx	Latched Manufacturer Warning Details

Latched Exceptions Status (F390)

Latched version of 0xF380.

Subindex 0x01 (F391)

Latched Device Warning Details: Latched version of 0xF381:01.

Subindex 0x02 (F391)

Latched Device Warning Details: Latched version of 0xF381:02.

Subindex 0x01 (F392)

Latched Manufacturer Warning Details: Latched version of 0xF382:01.

Subindex 0x02 (F392)

Latched Manufacturer Warning Details: Latched version of 0xF382:02.

4.7.10 Latched Device Error Details

Index	SI	Data Type	NV	Access	PM	Name
F393	0x01	UDINT		RO	tx	Latched Device Error Details
	0x02	UDINT		RO	tx	Latched Device Error Details
F394	0x01	UDINT		RO	tx	Latched Manufacturer Error Details
	0x02	UDINT		RO	tx	Latched Manufacturer Error Details

Subindex 0x01 (F393)

Latched Device Error Details: Latched version of 0xF383:01.

Subindex 0x02 (F393)

Latched Device Error Details: Latched version of 0xF383:02.

Subindex 0x01 (F394)

Latched Manufacturer Error Details: Latched version of 0xF384:01.

Subindex 0x02 (F394)

Latched Manufacturer Error Details: Latched version of 0xF384:02.

4.7.11 Latched Global Device Warning Details

Index	SI	Data Type	NV	Access	PM	Name
F395	0x01	UDINT		RO	tx	Latched Global Device Warning Details
F396	0x01	UDINT		RO	tx	Latched Global Manufacturer Warning Details

Subindex 0x01 (F395)

Latched Device Warning Details: Latched version of 0xF385:01.

Subindex 0x01 (F396)

Latched Manufacturer Warning Details: Latched version of 0xF386:01.

4.7.12 Latched Global Device Error Details

Index	SI	Data Type	NV	Access	PM	Name
F397	0x01	UDINT		RO	tx	Latched Global Device Error Details
F398	0x01	UDINT		RO	tx	Latched Manufacturer Error Details

Subindex 0x01 (F397)

Latched Device Error Details: Latched version of 0xF387:01.

Subindex 0x01 (F398)

Latched Manufacturer Error Details: Latched version of 0xF388:01.

4.7.13 Device Warning Mask

Index	SI	Data Type	NV	Access	PM	Name
F3A1	0x01	UDINT	x	RW		Device Warning Mask
	0x02	UDINT	x	RW		Device Warning Mask
F3A2	0x01	UDINT	x	RW		Manufacturer Warning Mask
	0x02	UDINT	x	RW		Manufacturer Warning Mask

Subindex 0x01 (F3A1)

Device Warning Mask: Mask bits for 0xF381:01 and 0xF391:01.

Subindex 0x02 (F3A1)

Device Warning Mask: Mask bits for 0xF381:02 and 0xF391:02.

Subindex 0x01 (F3A2)

Manufacturer Warning Mask: Mask bits for 0xF382:01 and 0xF392:01.

Subindex 0x02 (F3A2)

Manufacturer Warning Mask: Mask bits for 0xF382:02 and 0xF392:02.

4.7.14 Device Error Mask

Index	SI	Data Type	NV	Access	PM	Name
F3A3	0x01	UDINT	x	RW		Device Error Mask
	0x02	UDINT	x	RW		Device Error Mask
F3A4	0x01	UDINT	x	RW		Manufacturer Error Mask
	0x02	UDINT	x	RW		Manufacturer Error Mask

Subindex 0x01 (F3A3)

Device Error Mask: Mask bits for 0xF383:01 and 0xF393:01.

Subindex 0x02 (F3A3)

Device Error Mask: Mask bits for 0xF383:02 and 0xF393:02.

Subindex 0x01 (F3A4)

Manufacturer Error Mask: Mask bits for 0xF384:01 and 0xF394:01.

Subindex 0x02 (F3A4)

Manufacturer Error Mask: Mask bits for 0xF384:02 and 0xF394:02.

4.7.15 Global Device Warning Mask

Index	SI	Data Type	NV	Access	PM	Name
F3A5	0x01	UDINT	x	RW		Global Device Warning Mask
F3A6	0x01	UDINT	x	RW		Global Manufacturer Warning Mask

Subindex 0x01 (F3A5)

Global Device Warning Mask: Mask bits for 0xF385:01 and 0xF395:01.

Subindex 0x01 (F3A6)

Manufacturer Warning Mask: Mask bits for 0xF386:01 and 0xF396:01.

4.7.16 Global Device Error Mask

Index	SI	Data Type	NV	Access	PM	Name
F3A7	0x01	UDINT	x	RW		Global Device Error Mask
F3A8	0x01	UDINT	x	RW		Manufacturer Error Mask

Subindex 0x01 (F3A7)

Device Error Mask Device: Mask bits for 0xF387:01 and 0xF397:01.

Subindex 0x01 (F3A8)

Manufacturer Error Mask: Mask bits for 0xF388:01 and 0xF398:01.

4.8 Device specific Profile Objects

The manufacturer-specific profile objects contain the manufacturer's data. The objects are described in the following tables.

4.8.1 Communication Gauge

Index	SI	Data Type	NV	Access	PM	Name
F640	0x01	BOOL		RO	tx	Combination Gauge Reading Valid
	0x02	BOOL		RO	tx	Combination Gauge Overrange Exceeded
	0x03	BOOL		RO	tx	Combination Gauge Underrange Exceeded
	0x11	REAL		RO	tx	Combination Gauge Active Value
	0x12	UINT		RO	tx	Combination Gauge Active Sensor Number

Subindex 0x01

Identifies whether the complete vacuum pressure gauge (with several measuring principles) is out of its absolute overrange or absolute underrange, or in any other failure condition.

Subindex 0x02

If the bit "Overrange" is set, all modules of the gauge are in an overrange condition.

Subindex 0x03

If the bit "Underrange" is set, all modules of the gauge are in an underrange condition.

Subindex 0x11

The value copied from the measurement value of the active measuring module used for the Input PDO.

Subindex 0x12

Identifies the module that is providing the measurement value, the latter of which is copied into the Active Value parameter for all Input PDO's.

0	No module has a valid value
1	Heat Transfer sensor is providing the Active Value
2	Hot Cathode sensor is providing the Active Value

4.8.2 Trip Point Output All

Index	SI	Data Type	NV	Access	PM	Name
F641	0x01	UDINT		RO	tx	Trip Point Output All Instance

Subindex 0x01

Status of Trip Point instances.

Trip Point Output All Instance	
Bit 0	Status High Trip (I 0x600E, SI 0x01)
Bit 1	Status Low Trip (I 0x600E S,I 0x02)
Bit 2	Status High Trip (I 0x600F, SI 0x01)
Bit 3	Status Low Trip (I 0x600F, SI 0x02)
Bit 4...31	0

4.8.3 Input Latch Local Timestamp

Index	SI	DataType	NV	Access	PM	Name
F6F0	0x01	UDINT		RO	tx	Input Latch Local Timestamp
	0x02	UDINT		RO	tx	Input Latch Local Timestamp

Subindex 0x01

Local controller time corresponding to the input latch time in microseconds. It starts at zero on device power-up. Mandatory if device has inputs. If device has no inputs defined, this corresponds the time immediately prior to writing to input SM.

Subindex 0x02

Local controller time corresponding to the input latch time in microseconds. It starts at zero on device power-up. Mandatory if device has inputs. If device has no inputs defined, this corresponds the time immediately prior to writing to input SM.

4.8.4 Configuration Device

Index	SI	DataType	NV	Access	PM	Name
F840	0x01	UDINT	x	RW		Data Units
	0x02	V_STRING		RW		Password
	0x03	Enum	x	RW		Data Units Enum

Subindex 0x01

Unit of the Value of the Analog Input Sensor Instance and all related parameters.

Trip Point Output All Instance	
0x00220000	Pascal
0xFD4E0000	mbar
0x00A10000	Torr
0x00E00000	Counts (INFICON)

If this value is changed, also Subindex 3 will change the value accordingly.

Subindex 0x02

Writing the corresponding password (vendor specified value) enables Access Rights (Index F940 Subindex 03)

Subindex 0x03

Data Unit for Input Sensor as Enum to have a list of possible values.

Data Units	
0x01(Pa)	Pascal
0x04(mBar)	mbar
0x05(Torr)	Torr

If this value is changed, also Subindex 1 will change the value accordingly.

4.8.5 Information Device

Index	SI	Data Type	NV	Access	PM	Name
F940	0x01	UDINT		RO		Measurement Principle
	0x02	BYTE		RO		Number of Sensors
	0x03	USINT		RO		Access Rights
	0x04	V_STRING	x	RO		SW Version VPG PCB
F9F0		V_STRING		RO		Manufacturer Serial Number
F9F1	0x01	UDINT		RO		CDP Functional Generation Number
F9F2	0x01	UDINT		RO		SDP Functional Generation Number (Module 1)
	0x02	UDINT		RO		SDP Functional Generation Number (Module 2)
F9F3		V_STRING		RO		Vendor Name
F9F4	0x01	V_STRING		RO		Semiconductor SDP Device Name (Module 1)
	0x02	V_STRING		RO		Semiconductor SDP Device Name (Module 2)
F9F5	0x01	USINT		RW	rx/tx	Output Identifier
	0x02	USINT		RW	rx/tx	Output Identifier
F9F6		UDINT		RO		Time Since Power On
F9F7		UDINT	x	RO		Time Total Powered
F9F8		UDINT		RO		Firmware Update Functional Generation Number

Subindex 0x01 (F940)

Measurement principle assigned to the object instance.

The most significant nibble of the parameter represents the sensor type of the first Module, the second most significant nibble of the parameter represents the sensor type of the second Module, and so forth.

Measurement Principle (Index F940)	
1	Capacitance Manometer
2	Piezo
3	Heat Transfer
4	Cold Cathode
5	Hot Cathode

Subindex 0x02 (F940)

Number of Sensors (Index F940): In this device are 2 sensors implemented.

Subindex 0x03 (F940)

Access Rights (Index F940)	
0	User access to measurement and limited diagnostic features
1	Service access to additional diagnostic features (vendor specific)
2	Superuser access to vendor-specific parameters and features, e.g. calibration parameters, model number, serial numbers

Subindex 0x04 (F940)

Software version of the basic device.

4.9 Command Objects

The manufacturer-specific profile objects contain the manufacturer's data. The objects are described in the following tables.

4.9.1 Command Degas ON / OFF

Execution of this command will initiate or cancel a degas operation.

Index	SI	DataType	NV	Access	PM	Name
FB43	0x01	V_STRING(2)		RW		Command
	0x02	BYTE		RO		Status
	0x03	V_STRING(3)		RO		Response

Subindex 0x01

A degas command is initiated when the following byte sequence is sent.

Command	
Byte 0	0: Degas OFF 1: Degas ON
Byte 1	Index of the Sub Sensor module has to be 2 2: Hot Cathode

Subindex 0x02

Status (supported values)	
0	Last command completed, no errors, no reply available
1	Last command completed, no errors, reply available
2	Last command completed, errors present, no reply available
3	Last command completed, errors present, reply available
255	Command is executing

Subindex 0x03

Response	
Byte 0	See Subindex 0x02
Byte 1	not used = 0x00
Byte 2	0: Degas ON / OFF successful 1: Degas ON / OFF failed (unspecified reason) 2: Degas On failed because pressure to high 254: No previous Degas ON / OFF command issued

4.9.2 Command Emission ON / OFF

Execution of this command will turn on or off the gauge's emission state.

Index	SI	DataType	NV	Access	PM	Name
FB44	0x01	V_STRING(2)		RW		Command
	0x02	BYTE		RO		Status
	0x03	V_STRING(3)		RO		Response

Subindex 0x01

An emission command is initiated when the following byte sequence is sent.

Command	
Byte 0	0: Emission OFF 1: Emission ON
Byte 1	Index of the Sub Sensor module has to be 2 2: Hot Cathode

Subindex 0x02

Status (supported values)	
0	Last command completed, no errors, no reply available
1	Last command completed, no errors, reply available
2	Last command completed, errors present, no reply available
3	Last command completed, errors present, reply available
255	Command is executing

Subindex 0x03

Response	
Byte 0	See Subindex 0x02
Byte 1	not used = 0x00
Byte 2	0: Emission ON / OFF successful 1: Emission ON / OFF failed (unspecified reason) 2: Emission On failed because pressure to high 254: No previous Emission ON / OFF command issued

4.9.3 Device Reset Command

Execution of this command causes the device to emulate a complete power cycle. This includes an ESC reset. An SDP may limit some behavior of the power cycle emulation, but shall not exclude the EtherCAT interface.



As consequence of an ESC reset all following devices are disconnected from the network.

There are two versions of this command:

- Standard reset (as described above)
- Factory reset (as described above, but additionally, all parameters are restored to as-shipped defaults).

Index	SI	Data Type	NV	Access	PM	Name
FBF0	0x01	V_STRING(6)		RW		Command
	0x02	BYTE		RO		Status
	0x03	V_STRING(2)		RO		Response

Subindex 0x01

A device reset is initiated when the following byte sequence is sent.

Command	
Byte 0	0x74
Byte 1	0x65
Byte 2	0x73
Byte 3	0x65
Byte 4	0x72
Byte 5	0x00 = Standard reset

Subindex 0x02

Status (supported values)	
0	Reserved
1	Reserved
2	Last command completed, error, no response
3	Reserved
255	Command is executing

Subindex 0x03

Response	
Byte 0	See Subindex 0x02
Byte 1	not used = 0x00

4.9.4 Exception Reset Command

Execution of this command clears the latched exceptions.

Index	SI	DataType	NV	Access	PM	Name
FBF1	0x01	V_STRING(5)		RW		Command
	0x02	BYTE		RO		Status
	0x03	V_STRING(2)		RO		Response

Subindex 0x01

A exception reset is initiated when the following byte sequence is sent.

Command	
Byte 0	0x74
Byte 1	0x65
Byte 2	0x73
Byte 3	0x65
Byte 4	0x72

Subindex 0x02

Status (supported values)	
0	Last command completed, no error, no response
1	Reserved
2	Last command completed, error, no response
3	Reserved
255	Command is executing

Subindex 0x03

Response	
Byte 0	See Subindex 0x02
Byte 1	not used = 0x00

4.9.5 Store Parameters Command

Execution of this command will store all parameters to non-volatile memory. If a device automatically saves all non-volatile parameters at the time they are set, this command will not take any action.

Index	SI	DataType	NV	Access	PM	Name
FBF2	0x01	V_STRING(4)		RW		Command
	0x02	BYTE		RO		Status
	0x03	V_STRING(2)		RO		Response

Subindex 0x01

All device parameters are stored when the following byte sequence is sent.

Read:

Command: Read	
Byte 0	0x01 = slave saves the non-volatile parameters when writing 0xFBFB2:01 with 0x65766173
Byte 1	not used = 0x00
Byte 2	not used = 0x00
Byte 3	not used = 0x00

Write:

Command: Write	
Byte 0	0x73
Byte 1	0x61
Byte 2	0x76
Byte 3	0x65

Subindex 0x02

Status (supported values)	
0	Last command completed, no error, no response
1	Reserved
2	Last command completed, error, no response
3	Reserved
255	Command is executing

Subindex 0x03

Response	
Byte 0	See Subindex 0x02
Byte 1	not used = 0x00

4.9.6 Calculate Checksum Command

Execution of this command will calculate a checksum for all writable, non-volatile parameters as currently stored in non-volatile memory.

Index	SI	Data Type	NV	Access	PM	Name
FBF3	0x01	V_STRING(4)		RW		Command
	0x02	BYTE		RO		Status
	0x03	V_STRING(6)		RO		Response

Subindex 0x01

A device reset is initiated when the following byte sequence is sent.

Read

Command: Read	
Byte 0	Bit 0 = 1: non-volatile parameters supported Bit 1 = 1: CRC-32 Bit 2..7 = 0: not used
Byte 1...3	not used = 0x00

Write

Command: Write	
Byte 0	Bit 0 = 1: use default checksum algorithm of the slave Bit 1 = 1: CRC-32 Bit 2..7 = 0: not used
Byte 1	not used = 0x00
Byte 2	not used = 0x00
Byte 3	not used = 0x00

Subindex 0x02

Status (supported values)	
0	Last command completed, no error, no response
1	Reserved
2	Last command completed, error, no response
3	Reserved
255	Command is executing

Subindex 0x03

Response	
Byte 0	See Subindex 0x02
Byte 1	not used = 0
Byte 2	Checksum return value, Byte 0
Byte 3	Checksum return value, Byte 1
Byte 4	Checksum return value, Byte 2
Byte 5	Checksum return value, Byte 3

4.9.7 Load Parameters Command

Execution of this command will load all parameters from non-volatile memory.

Index	SI	DataType	NV	Access	PM	Name
FBF4	0x01	V_STRING(4)		RW		Command
	0x02	BYTE		RO		Status
	0x03	V_STRING(2)		RO		Response

Subindex 0x01

A device reset is initiated when the following byte sequence is sent.

Read:

Command: Read	
Byte 0	0x01 = slave loads the non-volatile parameters when writing 0xFBF4:01 with 0x64616F6C
Byte 1	not used = 0x00
Byte 2	not used = 0x00
Byte 3	not used = 0x00

Write:

Command: Write	
Byte 0	0x6C
Byte 1	0x6F
Byte 2	0x61
Byte 3	0x64

Subindex 0x02

Status (supported values)	
0	Last command completed, no error, no response
1	Reserved
2	Last command completed, error, no response
3	Reserved
255	Command is executing

Subindex 0x03

Response	
Byte 0	See Subindex 0x02
Byte 1	not used = 0x00

Appendix

A: Overview Setting Trip Points

Input Data Trip Point

Index	Object Code	Sub Index	Data Type	Access	B/S	PM	Name	Description
0x6nnx	RECORD			RO			Input Trip Point 1 / 2	Trip Point 1 / Trip Point 2 E = Trip Point 1 F = Trip Point 2
0x600E 0x600F		0x01	BOOL	RO		tx	Status High Trip	1: High Trip asserted
0x600E 0x600F		0x02	BOOL	RO		tx	Status Low Trip	2: Low Trip asserted

Trip Point 1 → 15

Trip Point 2 → 15

Trip Point Configuration

Index	Object Code	Sub Index	Data Type	Access	B/S	PM	Name	Description
0x8nnx	RECORD			RO			Configuration Trip Point 1 / 2	Trip Point 1 / 2 E = Trip Point 1 F = Trip Point 2
0x800E 0x800F		0x01	BOOL	RW	B/S		High Trip enable	High Trip Point 0: disable 1: enable
0x800E 0x800F		0x02	BOOL	RW	B/S		Low Trip enable	Low Trip Point 0: disable 1: enable
0x800E 0x800F		0x11	REAL	RW	B/S		High Trip Point Limit	Mandatory, if 0x8nnE.20 is not supported (Low Trip Point Limit). High limit to trigger trip point condition, if Input Value (I 0x9nnE, SI 0x01) is above this limit.
0x800E 0x800F		0x12	UDINT	RW	B/S		High Trip Source Index	Object index of High Trip Point Value source. Bit 16...31: Index Bit 08...15: Subindex Bit 00...07: reserved It is possible to reference to "High Trip Point Limit" or any other available input source from another sensor (in case of combi / multigauges).
0x800E 0x800F		0x13	REAL	RW	B/S		Percentage High Trip Source	Percentage of value referenced by High Trip Source Index (I 0x8nnE, SI 0x12) in %.
0x800E 0x800F		0x14	REAL	RW	B/S		Low Trip Point Limit	Mandatory, if 0x8nnE.17 is not supported (High Trip Point Limit). Low limit to trigger trip point condition, if Input Value (I 0x9nnE, SI 0x01) is below this limit.

(continued)

(Table "Trip Point Configuration" concluded)

Index	Object Code	Sub Index	Data Type	Access	B/S	PM	Name	Description
0x800E 0x800F		0x15	UDINT	RW	B/S		Low Trip Source Index	Object index of Low Trip Point Value source. Bit 16...31: Index Bit 08...15: Subindex Bit 00...07: reserved It is possible to reference to "Low Trip Point Limit" or any other available input source from another sensor (in case of combi / multigauges.
0x800E 0x800F		0x16	REAL	RW	B/S		Percentage Low Trip Source	Percentage of value referenced by Low Trip Source Index (I 0x8nnE, SI 0x15) in %.
0x800E 0x800F		0x17	REAL	RW	B/S		High Trip Hysteresis	Mandatory, if 0x8nnE.17 is not supported (High Trip Point Limit). Hysteresis value for High Trip Point.
0x800E 0x800F		0x18	REAL	RW	B/S		Low Trip Hysteresis	Mandatory, if 0x8nnE.20 is not supported (Low Trip Point Limit). Hysteresis value for Low Trip Point.
0x800E 0x800F		0x1A	UDINT	RW	B/S		Source Index	Mandatory, if combi and multigauges and High Trip Point Limit or Low Trip Point Limit supported. Object index of active source of Input Value (I 0x9nnE, SI 0x01). Bit 16...31: Index Bit 08...15: Subindex Bit 00...07: reserved

Trip Point 1 → 16

Trip Point 2 → 18

Information Data of the Modules

Index	Object Code	Sub Index	Data Type	Access	B/S	PM	Name	Description
0x9nnx	RECORD			RO			Information Trip Point 1 / 2	Trip Point 1 / Trip Point 2 E = Trip Point 1 F = Trip Point 2
0x900E 0x900F		0x01	REAL	RO			Input Value of Trip Point 1 / 2	Mandatory, if 0x8nnE.26 is not supported (Source Index). Trip Point Input value as referenced by Source Index (I 0x8nnE, SI 0x1A).

Trip Point 1 / 2 → 22

Trip Point All Slots Combined

Index	Object Code	Sub Index	Data Type	Access	B/S	PM	Name	Description
0xF641	RECORD			RO			Trip Point Output All	Trip Point Output All
0xF641		0x01	UDINT	RO		TX	Trip Point Output All Instance	Status of Trip Point Instances Bit 0: Status High Trip (I 0x6nnE, SI 0x01) Bit 1: Status Low Trip (I 0x6nnE, SI 0x02) Bit 2: Status High Trip (I 0x6nnF, SI 0x01) Bit 3: Status Low Trip (I 0x6nnF, SI 0x02)

Trip Point 1 / 2 → 27

B: Literature

- [1] www.inficon.com
Instruction Sheet
BPG402-S, BPG402-SD, BPG402-SE, BPG402-SL, BPG402-SP
tima46d1 (German)
tima46e1 (English)
INFICON AG, LI-9496 Balzers, Liechtenstein
- [2] www.inficon.com
Instruction Sheet
BPG402-SD, BPG402-SE, BPG402-SP
tima47d1 (German)
tima47e1 (English)
INFICON AG, LI-9496 Balzers, Liechtenstein
- [3] www.inficon.com
Operating Manual
BPG402-S, BPG402-SD, BPG402-SE, BPG402-SL, BPG402-SP
tina46d1 (German)
tina46e1 (English)
INFICON AG, LI-9496 Balzers, Liechtenstein
- [4] ETG.1000.2: Physical Layer service definition and protocol specification
- [5] ETG.1000.3: Data Link Layer service definition
- [6] ETG.1000.4: Data Link Layer protocol specification
- [7] ETG.1000.5: Application Layer service definition
- [8] ETG.1000.6: Application Layer protocol specification
- [9] ETG.1020: EtherCAT Protocol Enhancements
- [10] ETG.2000: EtherCAT Slave Information
- [11] ETG.5001.1: Modular Device Profile – Part 1: General MDP Device Model
- [12] ETG.5003.1 S (R) V1.1.0: Semiconductor Device profile – Part 1: Common Device Profile (CDP)
- [13] ETG.5003.2080 S (R) V1.3.0: Semiconductor Device profile – Part 2080: Specific Device Profile (SDP): Vacuum Pressure Gauge
- [14] IEC 61158-x-12 (all parts for type 12): Industrial communication networks – Fieldbus specifications
- [15] IEC 61784-2: Industrial communication networks – Profiles – Part 2: Additional fieldbus profiles for real-time networks based on ISO/IEC 8802-3
- [16] SEMI E54 / Draft 5102A: SPECIFICATION FOR SENSOR/ACTUATOR NETWORK SPECIFIC DEVICE MODEL FOR VACUUM PRESSURE GAUGES
- [17] SEMI E52: Practice for referencing gases, gas mixtures and vaporizable materials used in digital mass flow controllers

Original: English



t i r b 5 3 e 1



*LI-9496 Balzers
Liechtenstein
Tel +423 / 388 3111
Fax +423 / 388 3700
reachus@inficon.com*

www.inficon.com