

Complete Gas Injection Kit



Operating Instructions

Contents

1. General.....	3
2. Safety Aspects.....	3
3. Shipping contents.....	4
4. Main Parts.....	5
5. Operation.....	6
Connecting gas supply.....	6
Connecting panel to Injection Kit/Injection Fix Kit.....	6
Locating the leak.....	8
To pressurize a larger surface.....	9
Pressurizing the leak surface.....	9
6. To use the Reference Leak.....	10
7. Maintenance.....	11
Reference Leak certificate.....	11
To change the Reference Leak.....	11
To change the Main Filter.....	12

1. General

Complete Gas Injection Kit is an accessory to Hydrogen Leak Detector EXTRIMA, when leak detecting on aircraft fuel tanks. The entry point inside the tank is often far from the exit point on the outside and tracer gas leak detection is the fastest way to find and repair the leak by back

tracing the gas. Using the Complete Gas Injection Kit is the easiest way to get the tracer gas from bottle to leak point and it also helps you to see that you have the correct pressure at the right time and that your instrument is calibrated and ready for use.

2. Safety Aspects

The tracer gas used is a mixture of 5% Hydrogen (H₂) in Nitrogen (N₂). It is non-flammable, non-toxic, non-corrosive and environmentally friendly.

This gas mixture contains no oxygen and releasing large amounts of gas in confined spaces may lead to asphyxiation.

The normal risks with all compressed gases must also be considered.

Before connecting tracer gas: confirm that your connectors or test fixture is designed for working at the specified test pressure.

Compressed gases contain much energy. Always carefully secure gas bottles before connecting pressure regulator.



Warning

Pure Hydrogen is a flammable gas. Use only ready-made mixtures of 5% Hydrogen in Nitrogen. This is a standard, industrial gas mixture used in various industrial applications.

Whenever the word Hydrogen is used throughout this manual it implies that hydrogen gas is safely mixed with Nitrogen in proportions 5% H₂ 95%N₂.



Hazard

The recommended tracer gas mixture contains no oxygen. Releasing large amounts of gas in confined spaces may displace the air and create a risk for asphyxiation.

3. Shipping Contents

Complete Gas Injection Kit (590-621)

Case with Panel		590-619
1x Reference Leak with Certificate		591-446
1x Allen Key for Diffuser House		591-476
1x Guide Ring 9 mm		598-054
1x Guide Ring 11 mm		598-055
1x Filter for Reference Leak		591-475
1x Reference Leak Dummy		598-165
1x Input Protection Cap		591-736
1x Output Protection Cap		591-737
1x Leak Protection Cap		591-738
20 m 4 mm Hose		591-728
1x Gas Out Connector	591-730+	591-731
1x Gas In Connector	591-730+	591-732
1x EX Zone 0 LED lamp		591-717

Injection Pad small 10 pcs	590-615
Injection Pad large 10 pcs	590-616

Injection Fix Kit	590-618
1x Injection plug 40 mm	599-055
3 x Modeling tools	591-720
1x Cutting Knife	591-711
1x Injection Fix Tube 40 mm x 10	598-150
1x Sealant Tape	591-712
1x Tape	591-716
10 m Plastic Bagging Film	591-721



4. Main Parts

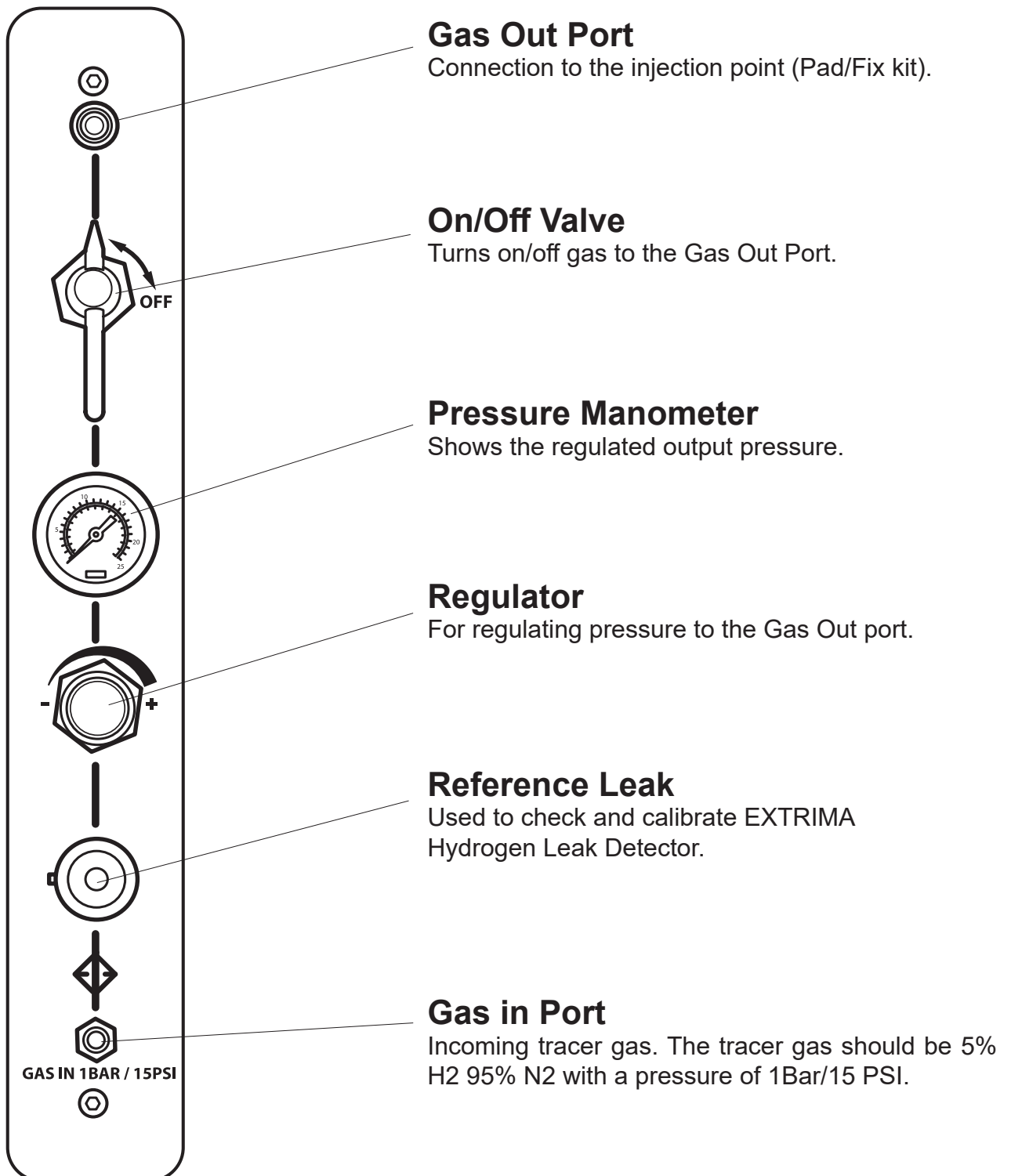

5. Operation

Connecting gas supply

Before fitting the regulator to the gas bottle, make sure that the bottle is protected and can not fall. Do not transport the gas bottle with regulator fitted!

- Fit the pressure regulator to the bottle. See manufacturer's instructions for details.

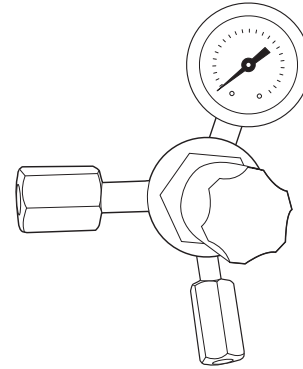

A two stage regulator with 0–1 bar / 0–15 psi output pressure is recommended.

- Connect a suitable length of supply hose to the output of the regulator. Use 4 mm or 5/32" outer diameter pneumatic tubing (PA or PUR).
- Connect the hose with the quick connector to the Gas in Port on the Injection Panel.

Connecting panel to Injection Pad/ Injection Fix Kit.

- Apply an Injection Pad or Injection Fix Kit according to the Instruction in the pad/kit package.

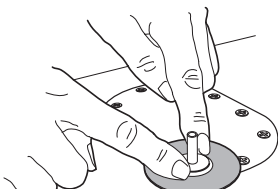
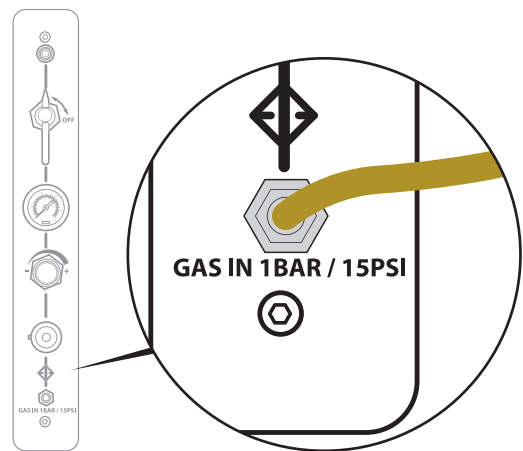

Injection Pad

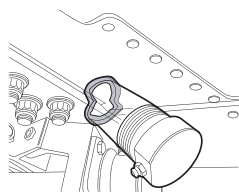

Injection Fix Kit

- Connect a suitable length of supply hose to Gas out Port on the Injection Panel. Use 4 mm or 5/32" outer diameter pneumatic tubing (PA or PUR). Do not connect to the Injection Pad/ Injection Fix Kit yet.

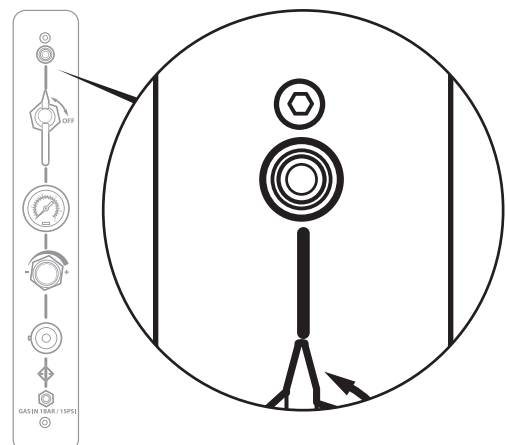

- Check that the ON /OFF valve is OFF.

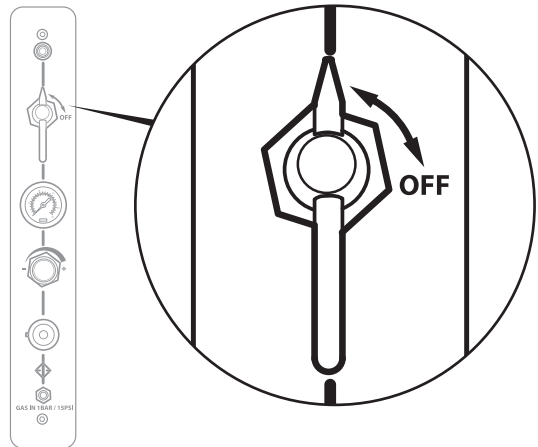

- Set the correct pressure from the bottle (1 Bar / 15 PSI).

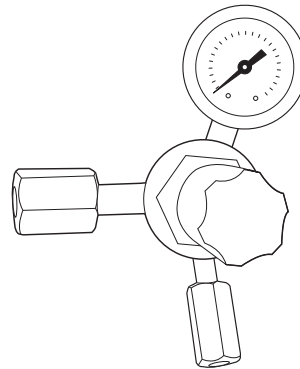

- Set output pressure to 0.1 bar (1.5 psi).

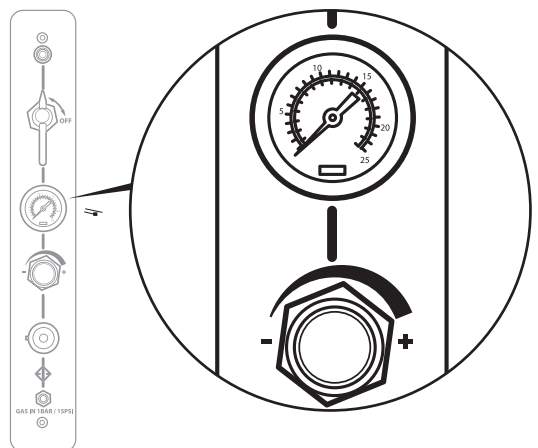

- Before connecting hose to injection point, open On/Off valve for a few seconds to purge hose.
- Close valve and immediately connect hose to the Pad/Fix kit.

Locating the leak

- Open the On/Off valv and increase output pressure slowly to desired pressure (max 0.5 bar / 7.2 psi).
- Check that pad is not peeling off. If so, reduce pressure and press pad back in place again.
- Wait for gas to clear path to entry point.
- Use Extrima to locate leaks.
- When a leak is detected, reduce pressure using the output regulator.
- Repair the leak.
- When the repair has cured enough to withstand pressure, increase pressure again and check that the leak is tight.

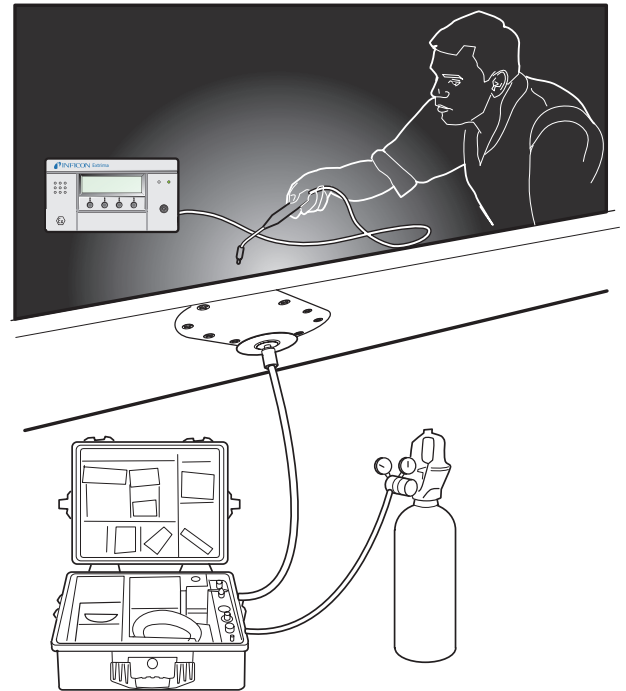

To pressurize a larger surface

- Clean area carefully with degreasing solvent before applying tape or Mastik.
- Cut off a piece of plastic film and tape it over the leaking surface as shown in the picture. Use Seal tape or Mastik to fix the plastic film in order to allow a higher pressure.
- Make a hole in the middle of the film and mount a small Injection Pad. Purge the hose from the Gas Out port as earlier described and connect it to the Injection Pad.

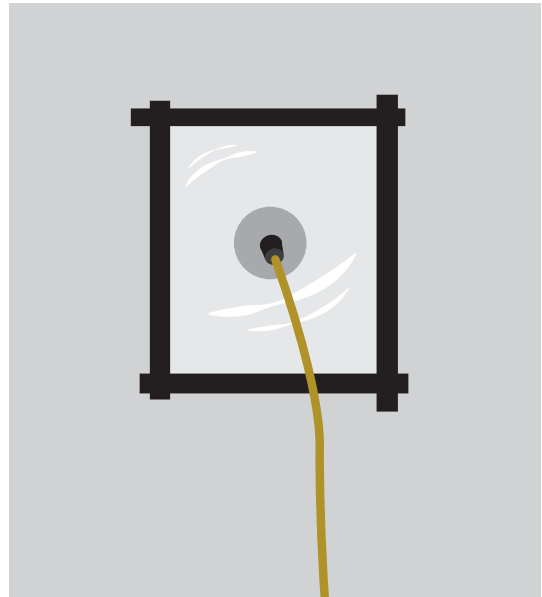

Pressurizing the leak surface

- Open the ON/OFF valve and adjust the pressure using the regulator on the Injection Panel, to make sure that there are no leaks from the covered surface.

Note! A larger surface normally means that you must use a considerably lower pressure.

- Wait for gas to clear path to the entry point and start leak detection with Extrima.

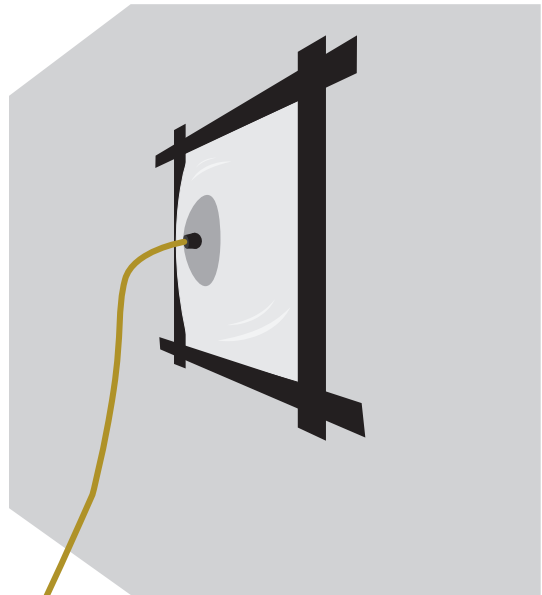

6. To use the Reference Leak

The Reference Leak is a reference used to calibrate the Extrima. The leak mounted in the case leaks 5×10^{-4} mbarl/s @1 barG (See certificate for exact value and pressure).

When a leak flow is 10^{-4} mbarl/s or less it is generally fluid tight (no stain).

10^{-2} mbarl/s is considered drop tight.

1 bar/15 psi gas pressure must be applied to the Gas in Port when using the Reference Leak.

For calibration — see the Extrima Manual.

Extrima function check: Put the hand probe into the reference leak as shown in the picture and check the signal on the Extrima. Re-move the probe immediately when the signal has stabilized.

Note! The regulator and manometer on the Injection Panel do not affect the reference leak.

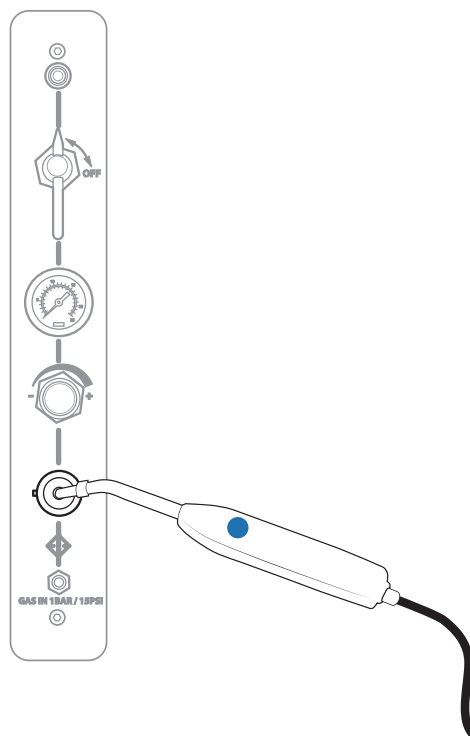

7. Maintenance

Reference Leak certificate

The reference leak is delivered with a certificate. To keep the certification valid the reference leak must be sent in to INFICON for re-calibration once a year. The reference leak can during re-calibration temporarily be replaced by the enclosed "dummy" leak.

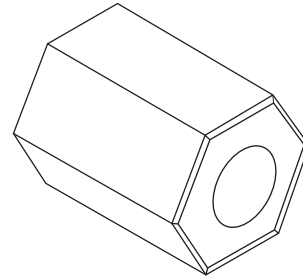

To change the Reference Leak

- Unscrew the diffuser. Mount the protective cap on the reference leak, the protective cap is found in the reference leak pack.
- Use a 14 mm spanner to remove the reference leak.

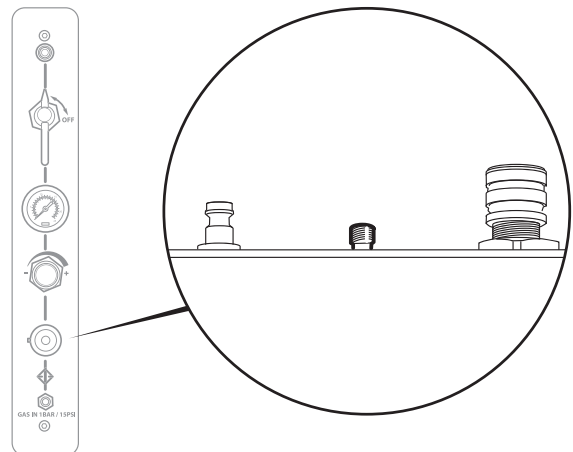
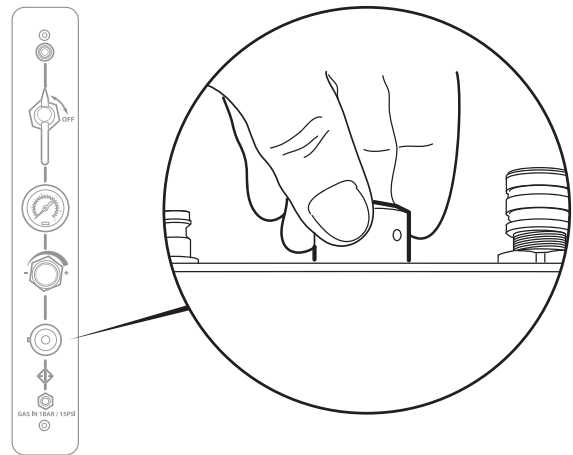

- Check the O-ring under the reference leak and replace it with a new O-ring if necessary.
- Replace the reference leak with a new one or mount the enclosed Reference Leak Dummy. Assemble in reverse order. Connect tracer gas to the panel and use Extrima to check that there are no leaks.

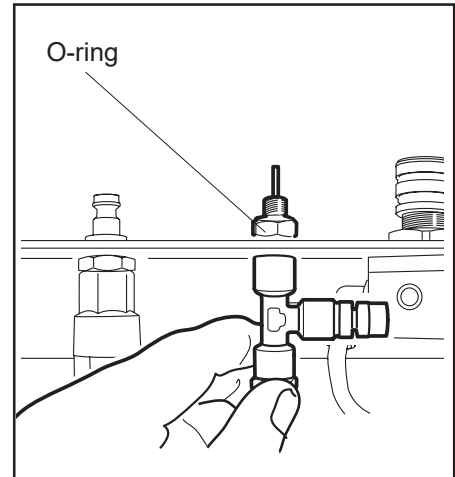

To change the Main Filter

- Check the filter once a year and change filter when needed. Remove the panel according to the description above. Unscrew the filter connections using two 14 mm spanners. Insert a new filter. Use Loctite 577 or similar to tighten the threads.
- Connect tracer gas to the panel and use Extrima to check that there are no leaks.

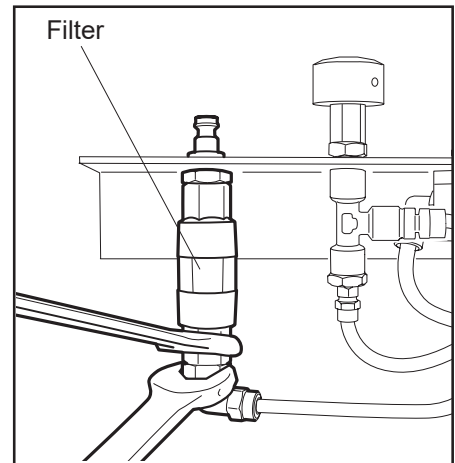

Spare Parts

591-727	Filter
591-735	O-ring 9,1 x 1,6
591-446	Reference Leak Type C



INFICON GmbH, Bonner Strasse 498, D-50968 Cologne, Germany

UNITED STATES TAIWAN JAPAN KOREA SINGAPORE GERMANY FRANCE UNITED KINGDOM HONG KONG

Visit our website for contact information and sales offices worldwide.

www.inficon.com

Document: ninm69en1-01 (1602)