

## SKY<sup>®</sup> CDG100D

### Heated Capacitance Diaphragm Gauge

INFICON SKY CDG100D manometers are your best choice for accurate total pressure measurement and control. CDG100D gauges are temperature controlled at 100°C for superior performance in demanding semiconductor and plasma processes. They are available for full scale ranges from 100 mTorr to 1000 Torr, with all common flange types and fieldbus interfaces and provide a linear 0 to 10 V, gas type independent, pressure signal. INFICON capacitance manometers use an ultra pure alumina ceramic diaphragm which is corrosion proof. The advantages of the ceramic sensor are better signal stability, faster recovery from atmosphere, short warm up time and an extraordinary lifetime. INFICON CDG are high quality, cost effective pressure sensors for demanding semiconductor, plasma and vacuum applications.



#### ADVANTAGES

- Lower cost of ownership, 50% faster warm up, energy efficient low power consumption
- Easy integration, wide variety of full scales, flanges and interfaces, standard with two set points
- Easy one push button or remote signal zero command, zero offset adjustable
- Diagnostic port for quick service and maintenance
- Two year warranty, longer lifetime with advanced heating concept and gauge protection
- No long term recalibration due to excellent signal stability and repeatability, even in harsh plasma applications
- Compliance and standards: CE, EN, UL, SEMI, RoHS

#### APPLICATIONS

- Etch, PVD, CVD and other semiconductor production processes
- Chemical and corrosive high temperature processes
- General thin film and vacuum processes requiring gauge protection

# SKY® CDG100D

## ORDERING INFORMATION

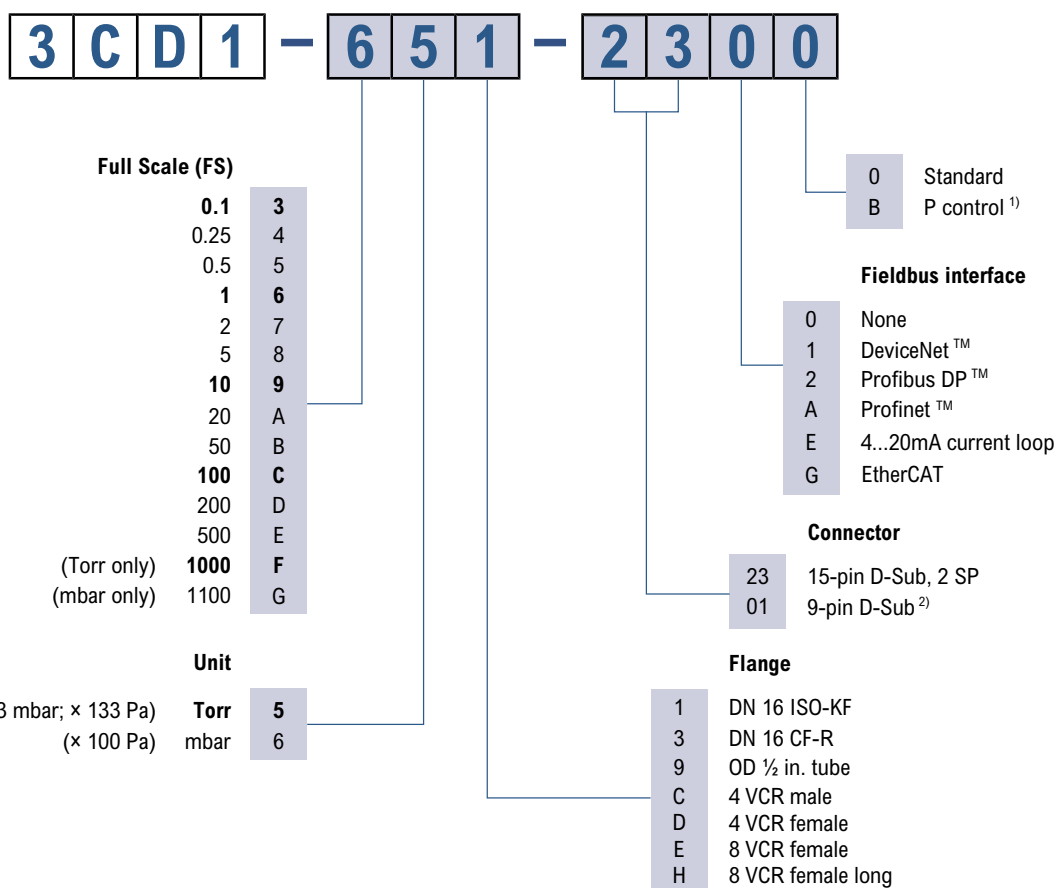

1) Optimized signal filter setting for pressure control

2) Not possible with fieldbus interfaces

bold = standard products

Other flange types on request.

## ACCESSORIES

Type	Part no.
Diagnostic cable RS232C; USB-A - phone jack 2.5mm (1.8m) <sup>1)</sup>	303-366

<sup>1)</sup> Diagnostic SW available upon request

## SKY<sup>®</sup> CDG100D

### SPECIFICATIONS

Full scale (FS)	1000 Torr, 1100 mbar	500 ... 1 Torr / mbar	0.5 ... 0.05Torr / mbar
Accuracy <sup>1)</sup>	0.2 % of reading	0.2 % of reading	0.4 % of reading
Temperature effect			
on zero	0.0025 % FS / °C	0.0025 % FS / °C	0.005 % FS / °C
on span	0.02 % of reading / °C	0.02 % of reading / °C	0.02 % of reading / °C
Pressure, max. (absolute)	400 kPa	260 kPa	130 kPa
Resolution		0.003 % FS	
Lowest reading		0.01 % FS	
Lowest suggested reading		0.05 % FS	
Lowest suggested control pressure		0.5 % FS	
Temperature			
Operation (ambient) <sup>2)</sup>		+10 ... +50 °C	
Bakeout at flange		≤110 °C	
Storage		-20 ... +65 °C	
Supply voltage		+14 ... +30 V (dc) or ±15 V (±5%)	
Power consumption			
During Heat up		≤15 W	
At operating temperature		≤10 W	
Output signal (analog)		0 ... +10 V (dc)	
Response time <sup>3)</sup>	30 ms	30 ms	130 / 30 ms <sup>4)</sup>
Degree of protection		IP 40	
Standards			
CE conformity		EN 61000-6-2, EN 61000-6-3, EN 61010	
ETL certification		UL 61010-1, CSA 22.2 No.61010-1	
SEMI compliance		SEMI S2	
Electrical connection		D-sub, 15-pin, male	
Setpoint			
Number of setpoints		2 (SP1, SP2)	
Relay contact		≤30 V (dc) / ≤0.5 A (dc)	
Hysteresis		1 % FS	
Diagnostic port			
Protocol		RS232-C	
Read		pressure, status, ID,	
Set		set points, filter, zero adjust, factory reset, DC offset	
Materials exposed to vacuum		ceramics (Al <sub>2</sub> O <sub>3</sub> ), stainless steel (AISI 316L )	
Internal volume		≤6.8 cm <sup>3</sup>	
Weight		892 ... 964 g	

<sup>1)</sup> Non-linearity, hysteresis, repeatability at 25°C ambient operating temperature without temperature effects after two hours operation

<sup>2)</sup> Ambient temperatures >40°C may increase surface temperature above SEMI S2 compliance levels — mark "caution hot!"

<sup>3)</sup> Increase 10 ... 90% FS

<sup>4)</sup> For pressure control type only

## SKY® CDG100D

### SPECIFICATIONS DEVICENET

#### DeviceNet™

Protocol	DeviceNet™, group 2 slave only
Data rate switch	125, 250, 500 kBaud or network programmable
Cable length	
125 kbps	500 m (1650 ft.)
250 kbps	250 m (825 ft.)
500 kbps	100 m (330 ft.)
MAC ID	Two switches (address 00 – 63) or network programmable
Digital functions	Read pressure, select units: Torr, mbar, Pa Degas function, Pirani full scale adjust Monitor gauge status Safe state allows definition of behavior in case of error Detailed alarm and warning information
Analog functions	0 ... 10 V analog output pressure indication two setpoint relays A + B
Visual communication indicators	LED network status (green / red) LED module status (green / red)
Specification	DeviceNet™ "Vacuum Gauge Device Profile"
Device type	"CG" for combination gauge
I / O slave messaging	Polling only
Setpoint relays	2
Range	$1 \times 10^{-9}$ ... 100 mbar
Relay contact	NO, potential free
Hysteresis	10 % of reading
Contact rating	60 V / 0.5 A (dc)
Supply voltage for DeviceNet™	+11 - +25 V / 0.5 A (dc)
Supply voltage for gauge	+20 - +28 V / 0.8 A (dc)
Connector for DeviceNet™	Microstyle, 5-pin
Connector for Gauges (analog output, supply voltage, setpoints)	D-Sub, 15-pin, male

### SPECIFICATIONS PROFIBUS DP

#### Profibus DP

Baud rates	9.6 / 19.2 / 93.75 / 187.5 / 500 kBaude 1.5 / 12 MBaud
Address	Two switches (address 00 - 127) or network programmable
Digital functions	Read pressure, select units: Torr, mbar, Pa Degas function, Pirani full scale adjust Monitor gauge status, filament status Safe state allows definition of behavior in case of error Detailed alarm and warning information
Analog functions	0 ... 10 V analog output pressure indication two setpoint relays A + B
Setpoint relays	2
Range	$1 \times 10^{-9}$ ... 100 mbar
Relay contact	NO, potential free
Hysteresis	10 % of reading
Contact rating	$\leq 30$ V / $\leq 0.5$ A (dc)

## SKY® CDG100D

### Profibus DP

Connector for Profibus DP	D-Sub, 9-pin, female
Connector for BPG (analog output, supply voltage, setpoints)	D-Sub, 15-pin, male

### SPECIFICATIONS ETHERCAT

#### EtherCAT®

Protocol	EtherCAT®, firmware generation 2.0
Communication standards	Semiconductor Device Profile ETG.5003 Part 1 Common Device Profile ETG.5003 Part 2080 "Specific Device Profile - Vacuum Pressure Gauge"
Process Data	Fixed PDO mapping and configurable PDO mapping
EtherCAT connector	RJ45, 8-pin (socket), IN and OUT
Cable	Shielded Ethernet CAT5e or higher
Cable length	≤100 m (330 ft.)
Data rate	100000 Kbps

### SPECIFICATION PROFINET

#### Profinet™

Communication protocol	protocol specialized for Profinet
Physical Layer	100BASE-Tx (IEEE 802.3)
Digital functions	
read	pressure, status, ID
set	set points, filter, zero adjust, reset, DC offset
Profinet connector	2 × RJ45, 8-pin (socket), IN and OUT
Cable	Special Ethernet Patch Cable or Crossover Cable, shielded (CAT5e quality or higher)
Cable length	≤100 m (330 ft.)
Data rate	100000 Kbps

# SKY<sup>®</sup> CDG100D

## DIMENSIONS

mm (inch)

