



LDS3000 helium and hydrogen leak detector

Maximum performance, minimum costs thanks to the revolutionary EcoBoost function.



 **INFICON**

Unsurpassed performance and innovation in the field of leak detection

Since its market launch, the LDS3000 has demonstrated unsurpassed performance in terms of accuracy, reproducibility of measurement results and speed of leak detection. The LDS3000 has made a name for itself as a benchmark in system leak detection and this makes it the first choice worldwide in all industries, especially among automotive and battery manufacturers, as well as in refrigeration and air conditioning technology.

Its compact design and wide range of modern fieldbus systems make it easy to integrate into your system.

For all applications that can be helium-critical, we are now able to offer the BEST solution: With the brand new EcoBoost function, helium consumption for measuring processes can be significantly reduced! EcoBoost can be retrofitted easily and free of charge or is included as standard in the new generation LDS3000.

YOUR BENEFITS AT A GLANCE

- ✓ Cost savings: The new and patented EcoBoost function makes it possible to save up to 90% of helium in the detection process. This reduces running costs and the investment costs of the instrument are amortized in a short time
- ✓ A compact design allows individual, customized integration into leak detection systems
- ✓ Quick and easy integration: Versatile communication options thanks to a wide range of analog and digital interfaces
- ✓ Process efficiency: Fast calibration of the LDS3000 within 20 seconds.

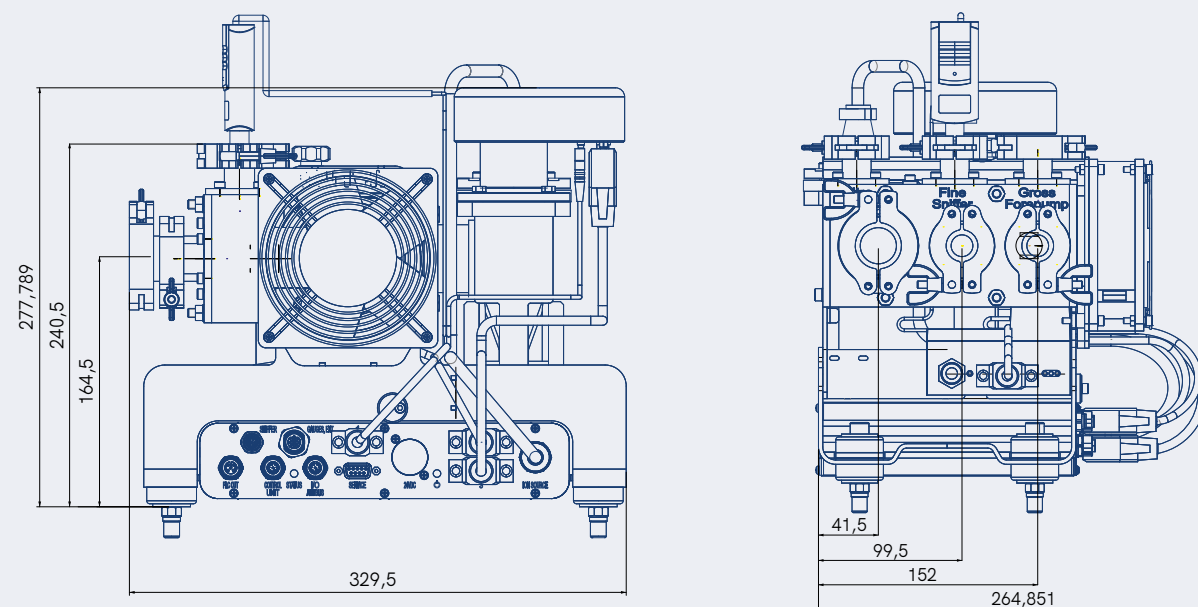

Dimensional drawing of the leak detector (dimensions in mm)

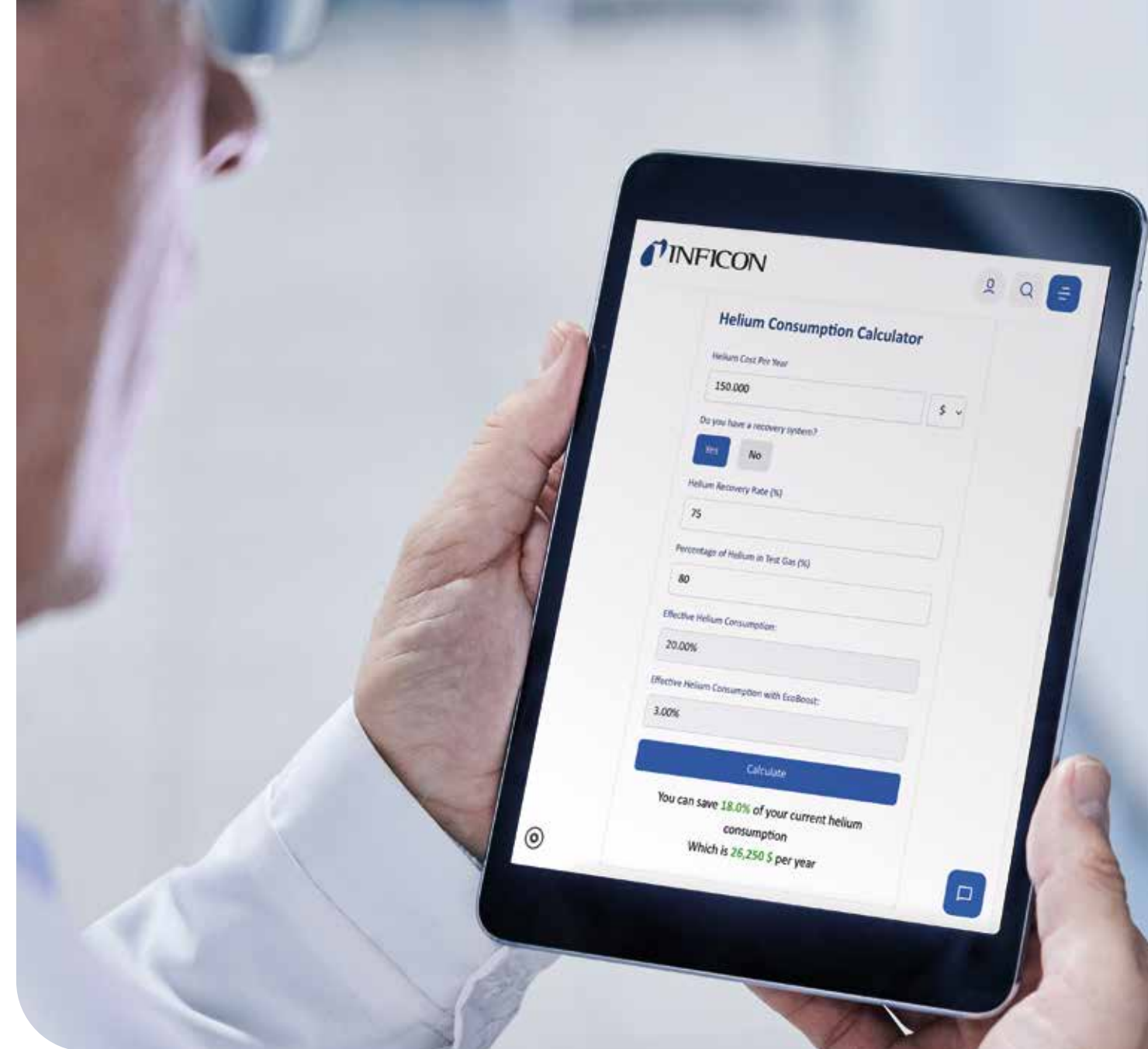

Helium Consumption Calculator: inficon.com/de/ecoboost-calculator

Find the smallest leaks, achieve maximum efficiency: LDS3000 and EcoBoost, an unbeatable duo

The LDS3000 detects even the smallest leaks with high reliability and delivers precise, reproducible measurement results at high speed, making it well suited for high-throughput applications.

Helium remains the preferred tracer gas for detecting very small leak rates, but its limited availability and cost require efficient use. The innovative and patented EcoBoost function further enhances the performance of the LDS3000 by drastically reducing helium consumption—by up to 90% compared to conventional methods—thereby lowering operating costs while providing a cost-effective and sustainable solution without compromising measurement accuracy.

Integrate seamlessly, achieve maximum flexibility

The compact design of the LDS3000 facilitates integration into existing systems. With a large number of interfaces, the LDS3000 offers versatile communication options that ensure seamless integration into the overall system.

INFICON also offers the CU1000 control unit for simple and convenient operation.

With INFICON as a partner, the smooth integration and optimum performance of your leak detection system is guaranteed.

Discover the LDS3000 with EcoBoost and benefit from its impressive functions. Contact us for more information on the savings potential of the EcoBoost function and to arrange a demo.



c TÜVus Certified
(NRTL tested)

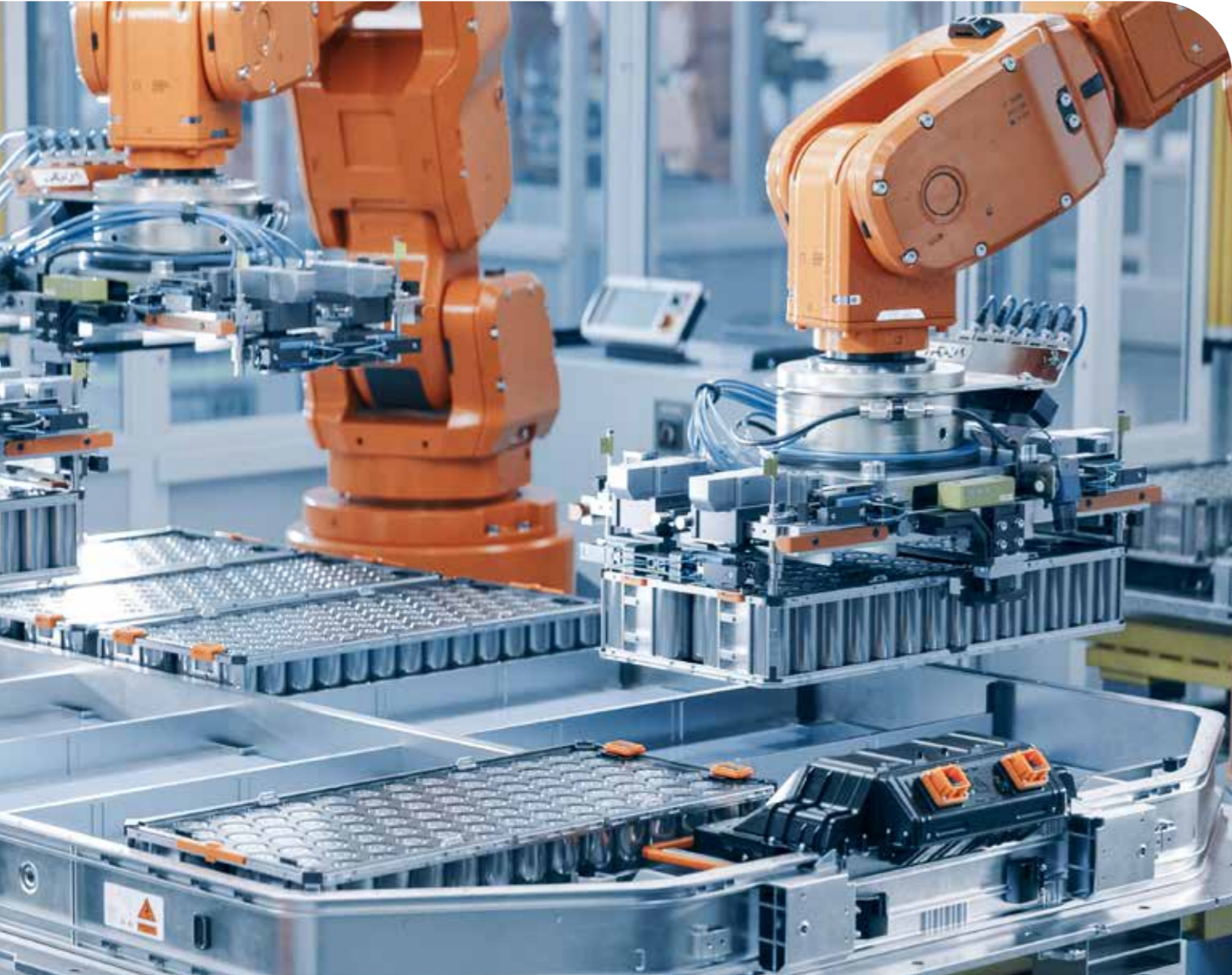

ROBUST, HIGH-EFFICIENCY TURBOMOLECULAR PUMP

Engineered for peak performance in challenging environments.

Its robust design ensures reliable operation and minimal maintenance, while providing rapid pump-down and supporting precise leak detection.

INFICON'S HIGH-PRECISION MASS SPECTROMETER

Engineered for maximum sensitivity and precision, the mass spectrometer at the core of the LDS3000 delivers outstanding performance.

Its advanced technology and robust design optimize production while maintaining high quality standards.

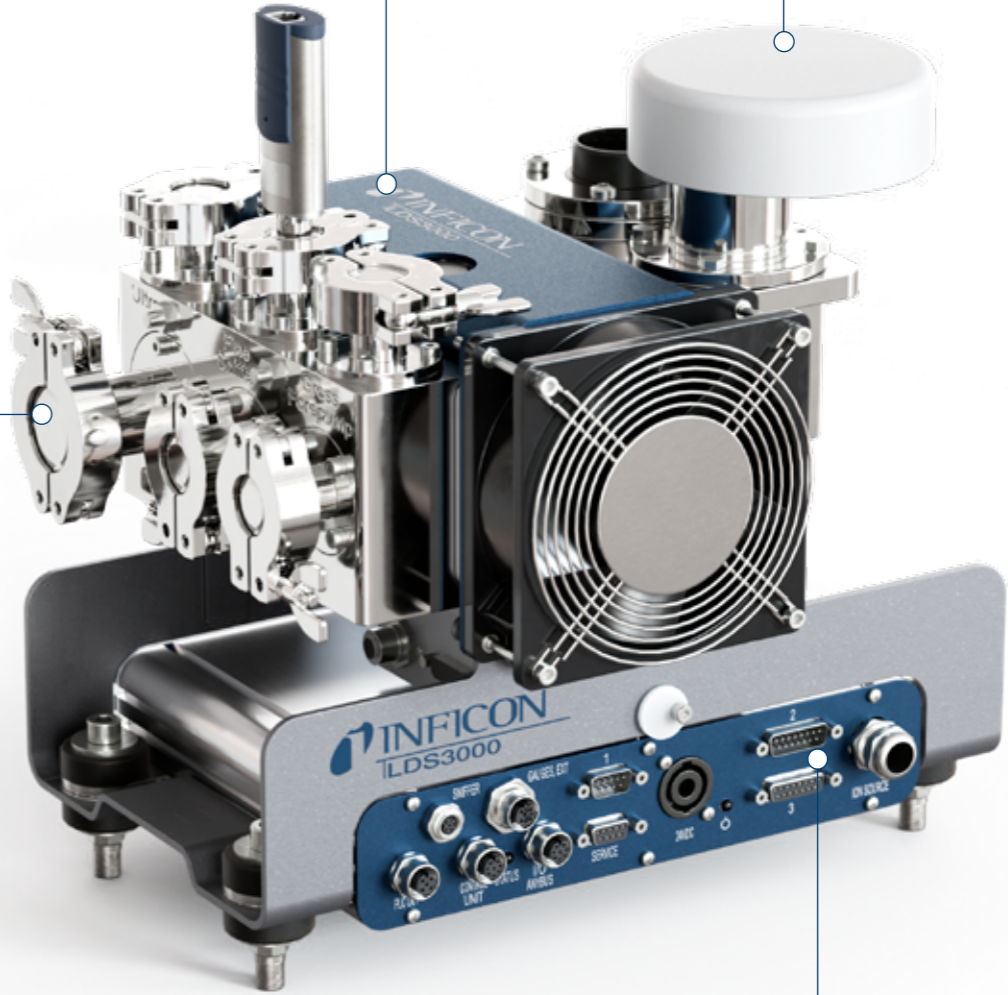

CONNECTION BLOCK

A masterpiece of versatility and precision with its gross, fine, and ultra connections, it offers tailored solutions for a wide range of applications.

INTEGRATED MSB BOX

In conjunction with the I/O 1000 and BM1000 modules, it offers versatile connection options for seamless integration with existing systems and efficient operation.



CU1000 CONTROL UNIT

With its installation-friendly design, the LDS3000 integrates seamlessly into existing systems. Clear parameter monitoring provides reliable and consistent process control.



CALIBRATION LEAKS

Wide range of calibration leaks—from standard models to customized solutions—ensuring accurate measurements and reliable performance.



I/O AND COMMUNICATION MODULES

I/O1000 and BM1000 modules offer versatile integration for the LDS3000, delivering precise control, reliable communication, and maximum system flexibility.



XL SNIFFER ADAPTER

Makes the LDS3000 a sniffer leak detector for both low- and high-flow modes. It enables leak detection from greater distances, even when sensitivity is reduced.



Performance you can depend on

INFICON offers the world's leading technology in the field of measuring technology, sensor technology and process control for sophisticated vacuum processes in highly specialized industries. Products for gas leak detection are used, in particular, in the refrigeration and air conditioning sectors, in semiconductor manufacturing and in automobile and battery production.

With INFICON, you have a competent service representative at your side who knows the

challenges of your industry and who, together with you, will find the optimal solution for your requirements.

INFICON ensures the best service and the greatest possible support for your company through our specialized experts in numerous branch offices worldwide. Our state-of-the-art production facilities are located in the USA, Europe and Asia.



TECHNICAL DATA

Minimum detectable leak rate of helium: "Ultra" mode "Fine" mode "Gross" mode "Sniffer" mode	$\leq 1 \cdot 10^{-11}$ mbar l/s (>5 l/s helium pumping speed) $\leq 5 \cdot 10^{-11}$ mbar l/s (1.7 l/s helium pumping speed) $\leq 1 \cdot 10^{-9}$ mbar l/s $\leq 1 \cdot 10^{-7}$ mbar l/s
Units of measurement (options)	mbar l/s, Pa m3/s, atm cc/s, g/a, ppm
Maximum permissible inlet pressure: "Gross" mode "Fine" mode "Ultra" mode	18 mbar 0.9 mbar 0.2 mbar
Response time	< 1 s
Ion source	2 yttrium/iridium long-life cathodes (3 year warranty)
Digital inputs/outputs	10 inputs, 8 outputs (when used with I/O1000 module)
Control input	PLC-compatible (max. 35 V)
Lin/log recorder output	0 - 10 V
Serial interface	RS232, RS485 or field bus systems
Dimensions (L x W x H)	330 x 240 x 280 mm
Ambient temperature (operation)	10 - 45°C
Warranty	2 years (3 years on ion source)

ORDERING INFORMATION

Base units

PRODUCT	CAT.-NO.	PRODUCT	CAT.-NO.
LDS3000, base unit	560-300	Sniffer valve	14520
I/O1000 module (input/output module)	560-310	Sniffer line, incl. handpiece, with 200 mm sniffer tip.	
BM1000 bus module (Profibus)	560-315	3 m line length	14521
Other bus modules upon request		5 m line length	14522
Data cable (MSB-I/O1000)		10 m line length	14523
2 m cable length	560-332	Replacement sniffer tip, 400 mm line length	20004 642
5 m cable length	560-335	XL Sniffer Adapter	560-319
10 m cable length	560-340	Diaphragm pump (recommended to use with the XL Sniffer Adapter)	560-330
Connection cable for display unit		External test leak with 100 % H2 (leak rate of test leak corresponds to (95/5) forming gas leak rate)	12322
5 m length	551-102	External helium test leak	12237
0.7 m length	551-103	Sniffer lines to use in combination with the XL Sniffer Adapter	
OPTIONS		SL3000XL-3, 3 m line length	521-011
CU1000 control unit	560-320	SL3000XL-5, 5 m line length	521-012
Snap-on mounting rail power supply unit 24 V, 10 A	560-324	SL3000XL-10, 10 m line length	521-013
Internal test leak TL7	560-323	SL3000XL-15, 15 m line length	521-014
Customized leaks	upon request		

An I/O1000 module or BM1000 module as well as a data cable are necessary for the operation of an LDS3000.

The data cables can be used for connecting to an I/O1000 module or a BM1000 bus module and the CU1000 control unit.



ISO 14001
ISO 9001

INNOVATION THROUGH PROVEN, PATENTED TECHNOLOGY

At INFICON, we know that technology leadership is not possible without innovation leadership. That is why we develop and implement pioneering solutions that enable our customers to master the future challenges of their industry with confidence.

 **INFICON** Inspired by visions. Proven by success.

www.inficon.com

reach.germany@inficon.com

Due to our continuing program of product improvements, specifications are subject to change without prior notice.

kiba40en1-06-(2601) © 2026 INFICON