

SKY™ Capacitance Diaphragm Gauge

CDG160-S

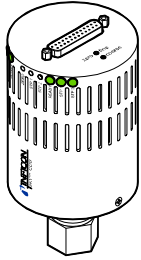

Operating Manual
Incl. Declaration of Conformity

tina08e1-a (0205)

Product Identification

In all communications with INFICON, please specify the information given on the product nameplate. For convenient reference copy that information into the diagram below.

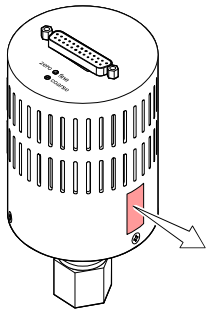

INFICON AG, LI-9496 Balzers

Model: _____

PN: _____

SN: _____

_____ V _____ W

Validity

This document applies to products with the following part numbers:

373-060	(10 ⁻¹ ... 1000 Torr (F.S.))
373-061	(10 ⁻² ... 100 Torr (F.S.))
373-062	(10 ⁻³ ... 10 Torr (F.S.))
373-063	(10 ⁻⁴ ... 1 Torr (F.S.))
373-065	(1.33×10 ¹ ... 133322 Pa (F.S.))
373-066	(1.33×10 ⁰ ... 13332.2 Pa (F.S.))
373-067	(1.33×10 ⁻¹ ... 1333.22 Pa (F.S.))
373-068	(1.33×10 ⁻² ... 133.322 Pa (F.S.))

The part number (PN) can be taken from the product nameplate.

We reserve the right to make technical changes without prior notice.

All dimensions in mm.

Intended Use

The Capacitance Diaphragm Gauges of the CDG160-S series are vacuum gauges and intended for absolute pressure measurement of gases in the pressure ranges specified in section "Validity".

The gauges can be operated in connection with an appropriate controller.

Functional Principle

The Capacitance Diaphragm Gauges consist of a capacitive sensor element made of aluminum oxide ceramic and electronics which convert the capacitance change into a DC voltage output signal.

The output signal is linear to the measured pressure and independent of the gas type ¹⁾.

The sensor is heated and its temperature kept constant at 160 °C to avoid contamination by process and process by-products.

The gauge also offers switching functions and status indicators.

Trademarks

SKY™ INFICON GmbH
VCR® Swagelok Marketing Co.

Safety

Symbols Used

DANGER

Information on preventing any kind of physical injury.

WARNING

Information on preventing extensive equipment and environmental damage.

Caution

Information on correct handling or use. Disregard can lead to malfunctions or minor equipment damage.

Personnel Qualifications

Skilled personnel

All work described in this document may only be carried out by persons who have suitable technical training and the necessary experience or who have been instructed by the end-user of the product.

General Safety Instructions

- Adhere to the applicable regulations and take the necessary precautions for the process media used. Consider possible reactions with the product materials. Consider possible reactions of the process media due to the heat generated by the product.
- Adhere to the applicable regulations and take the necessary precautions for all work you are going to do and consider the safety instructions in this document.
- Before beginning to work, find out whether any vacuum components are contaminated. Adhere to the relevant regulations and take the necessary precautions when handling contaminated parts.

Communicate the safety instructions to all other users.

Liability and Warranty

INFICON assumes no liability and the warranty becomes null and void if the end-user or third parties

- disregard the information in this document
- use the product in a non-conforming manner
- make any kind of interventions (modifications, alterations etc.) on the product
- use the product with accessories not listed in the product documentation.

The end-user assumes the responsibility in conjunction with the process media used.

Technical Data

Measurement ranges	→ "Validity"
Accuracy	0.5% of reading
Resolution	0.005% F.S.
Temperature effect on zero	0.005% F.S. /°C
Temperature effect on span	0.02% of reading /°C
Gas type dependence	none ¹⁾

Output signal (measurement signal)	
measurement range	0... +10.0 V
voltage range	-11.0 ... +11.0 V
voltage vs. pressure	linear ¹⁾
Output impedance	200 Ω (short-circuit proof)
Minimum loaded impedance	10 kΩ
Response time	50 ms

Gauge identification	Resistance 13.2 kΩ referenced to supply common
----------------------	--

Supply

DANGER

The gauge may only be connected to supply or measurement units that conform to the requirements of a grounded protective extra-low voltage (SELV-E according to EN 61010). The connection to the gauge has to be fused.

Supply voltage at the gauge	±15 VDC ±5% (ripple ≤0.3 V _{pp})
Current	≤0.9 A
Power consumption	
while heating	≤27 W
at operating temperature	≤15 W (The power consumption strongly depends on the temperature of the vacuum connection.)
Internal fuse	900 mA, slow reaction, automatic reset (Polifuse)
The gauge is protected against polarity change of the supply voltage.	

Status indication	
supply voltage o.k. (only the +15 V voltage supply is monitored)	U ≥ +12 V; hysteresis = 0.5 V
<POWER> LED green	

Electrical connection	D-Sub, male, 25 poles
Sensor cable	22 poles plus shielding
Cable length	≤50 m (22×0.5 mm ²)
For longer cables, bigger conductor cross-sections are required (R _{conductor} ≤ 1.0 Ω).	

Grounding concept	→ "Electrical Connection"
supply common–signal common	conducted separately, for differential measurement

¹⁾ For p < 1 mbar and T_{Gauge} ≠ T_{Vacuum}, the linearity of temperature-controlled gauges is influenced by the thermal transpiration (gas type dependent) at the maximum in the same order of magnitude as the zero point stability. See K. F. Poulter, et al., Vacuum 33, 331 (1983); W. Jitschin and P. Röhl, J. Vac. Sci. Technol. A, Vol. 5, No. 3, 1987.

Relay functions	relay active if:
"Temp sensor not defect"	temperature sensor o.k.
"Overheat detection"	sensor temperature $T > 200\text{ °C}$, $0 \dots +5\%$
"Temp ready"	sensor temperature $T = T_c \pm 5\%$, where $T_c = 160\text{ °C}$ (controlled sensor temperature)
"Setpoint 1"	$p \leq \text{setpoint level 1}$
"Setpoint 2"	$p \leq \text{setpoint level 2}$

Relay outputs	
type of contact	NC/NO change-over
switching voltage	$\leq 110\text{ VDC} / 125\text{ VAC}$
switching current	$\leq 1\text{ A DC/AC peak}$

Setpoints (adjustable)	2
Switching range	
voltage	$0 \dots 10\text{ V}$
hysteresis	40 mV
pressure	$0 \dots 100\% \text{ F.S.}$

Materials exposed to vacuum	
vacuum connection, tube, protective chamber, plasma shield	stainless steel AISI 316L
sensor housing, diaphragm connection	ceramic ($\text{Al}_2\text{O}_3 \geq 99.5\%$)
sensor housing – diaphragm	glass ceramic solder
ceramic – metal	AgCu hard solder, Vacon 70 (28% Ni, 23% Co, 49% Fe)

Internal volume	6 cm^3
Admissible pressure	
373-060	$\leq 3000\text{ Torr}$ (absolute)
373-065	$\leq 399966\text{ Pa}$ (absolute)
373-061 ... 373-063	$\leq 2000\text{ Torr}$ (absolute)
373-066 ... 373-068	$\leq 266644\text{ Pa}$ (absolute)

Admissible temperatures	
process gas at sensor	$\leq 200\text{ °C}$
vacuum connection	$\leq 160\text{ °C}$
ambiance	$+15\text{ °C} \dots +50\text{ °C}$
storage	$-40\text{ °C} \dots +65\text{ °C}$

Relative humidity	$\leq 80\%$ at temperatures $\leq +31\text{ °C}$, decreasing to 50% at $+40\text{ °C}$
-------------------	--

Mounting orientation	any → "Installation"
Use	indoors only altitude up to 2000 m NN
Protection category	IP 30

Dimensions [mm]

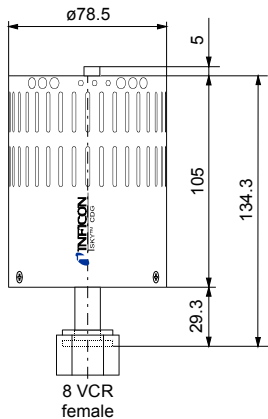

Weight 600 g

Output Signal vs. Pressure

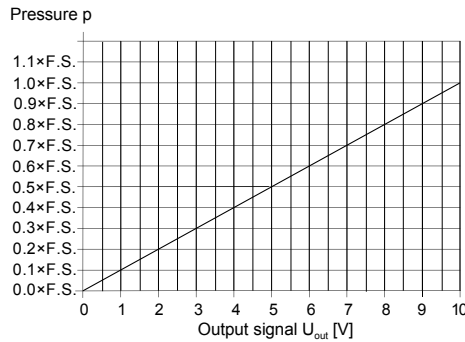

$$p = (U_{\text{out}} / 10\text{ V}) \times p(\text{F.S.})$$

Example: Gauge with 10 Torr F.S.
Output signal $U_{\text{out}} = 6\text{ V}$

$$p = (6\text{ V} / 10\text{ V}) \times 10\text{ Torr} = 0.6 \times 10\text{ Torr} = 6\text{ Torr}$$

Conversion Torr ↔ mbar		Conversion Pascal ↔ mbar	
Torr	mbar ²⁾	Pa	mbar ²⁾
1.00	$1013.25 / 760 = 1.3332\dots$	1.00	0.01

Installation

Vacuum Connection

STOP DANGER

Caution: overpressure in the vacuum system >750 Torr, 100000 Pa

Injury caused by released parts and harm caused by escaping process gases can result if clamps are opened while the vacuum system is pressurized.

Do not open any clamps while the vacuum system is pressurized. Use the type clamps which are suited to overpressure.

STOP DANGER

Caution: protective ground

Incorrectly grounded products can be extremely hazardous in the event of a fault.

Electrically connect the gauge to the grounded vacuum chamber. This connection must conform to the requirements of a protective connection according to EN 61010: 8 VCR connections fulfill this requirement.

Caution

Caution: vacuum component

Dirt and damages impair the function of the vacuum component.

When handling vacuum components, take appropriate measures to ensure cleanliness and prevent damages.

Caution

Caution: dirt sensitive area

Touching the product or parts thereof with one's bare hands increases the desorption rate.

Always wear clean, lint-free gloves and use clean tools when working in this area.

The gauge may be mounted in any orientation. However, it should be mounted so that no vibrations occur and that no particles and condensates can penetrate into the measuring chamber. If it should be possible to adjust the gauge while it is mounted, make sure its two trimmer potentiometers <zero coarse> and <zero fine> are accessible with a screw driver. The vacuum connection may be heated at the maximum to the controlled sensor temperature of 160 °C .

Remove the threaded plug and connect the product to the vacuum system.

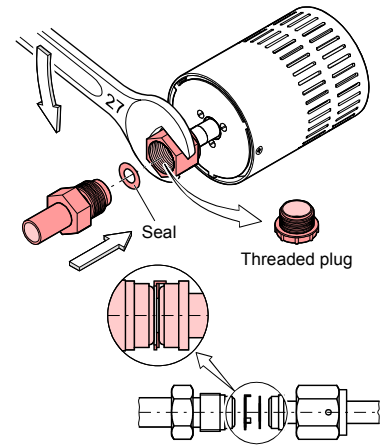

Electrical Connection

Make sure the vacuum connection is properly made (→ "Vacuum Connection").

If no connection cable is available, make one according to the following diagram.

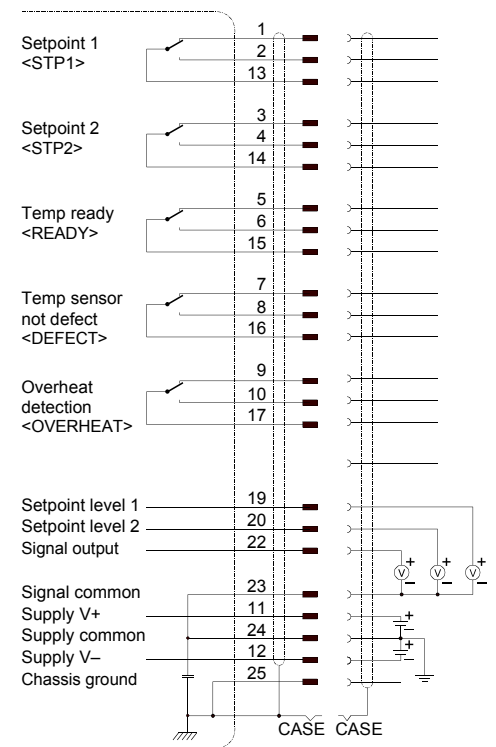

Pins 18 and 21 are not assigned in the gauge. Contacts shown in de-energized state.

²⁾ Source: NPL (National Physical Laboratory) Guide to the Measurement of Pressure and Vacuum ISBN 0904457x / 1998.



Connector soldering side

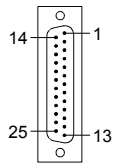

25-pole D-Sub, female

- 2 Connect the cable to the gauge.
- 3 Secure the cable socket to the gauge connector with the lock screws.
- 4 Connect the sensor cable to the controller.

Operation

Turn the gauge on. The sensor is heated and its temperature kept constant at 160 °C.

If the vacuum connection is not heated, it takes up to 2 hours until the output signal of the gauge reaches a stability of 5 mV. If the vacuum connection is heated, the warm-up time is reduced accordingly.

Gas type dependence

The measured value is independent of the gas type ¹⁾.

Zeroing the Gauge <zero>

When the gauge is put into operation for the first time, its zero should be adjusted.

Due to long time operation or contamination, a zero drift could occur. Periodically check the zero and adjust it if necessary.

Adjust the zero at the ambient temperature at which the gauge is normally operated. The gauge should be adjusted in the position in which it will be operated.

- 1 Evacuate the gauge to a pressure in accordance with the table below:

	Recommended final pressure for zero adjustment	
373-060	$<5 \times 10^{-2}$ Torr	
373-061	$<5 \times 10^{-3}$ Torr	
373-062	$<5 \times 10^{-4}$ Torr	
373-063	$<5 \times 10^{-5}$ Torr	
373-065		$<6.65 \times 10^0$ Pa
373-066		$<6.65 \times 10^{-1}$ Pa
373-067		$<6.65 \times 10^{-2}$ Pa
373-068		$<6.65 \times 10^{-3}$ Pa

- 2 Operate the gauge for at least two hours.
- 3 Adjust the gauge measuring the output signal (measurement signal) with a reliable, correctly calibrated (at least) 4-digit instrument.
- 4 Only when operating the gauge for the first time:
The influence of the mounting orientation on the output signal can be compensated by adjusting the output signal to $-0.2 \dots +0.2$ VDC via the <zero coarse> potentiometer by means of a screwdriver (1.5 mm).

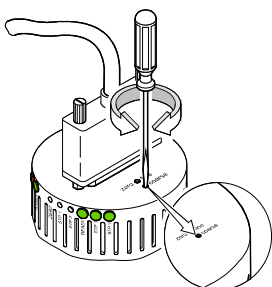

- 5 With a screwdriver (1.5 mm) adjust the potentiometer <zero fine> adjacent to the connector or the potentiometer <zero> on the periphery, between the visual indicators, so that the output signal is 0.000 VDC.

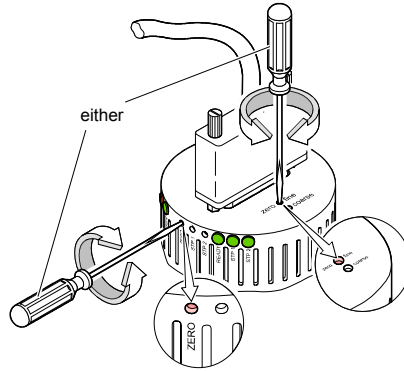

Status Indicators

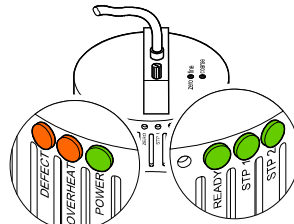

LED	Status	Meaning
<DEFECT>	red	Temperature sensor faulty
<OVERHEAT>	red	Sensor temperature $T > 200$ °C
<POWER>	green	Supply voltage o.k.
<READY>	green	Sensor temperature T_c o.k.
<STP1>	green	$p \leq$ setpoint level 1
<STP2>	green	$p \leq$ setpoint level 2

Defect

The heat controller stops the heatpower when this function is activated.

Overheat

When this function is activated, the heat controller stops the heatpower. Once activated, this function can only be reset by turning the gauge off.

Setpoints

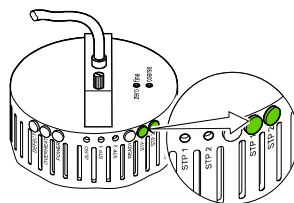

The gauge has two adjustable setpoints. With the potentiometers STP1 and STP2, the setpoints can be assigned to any pressure within the measurement range of the gauge. The setpoints are output at the D-Sub connector and can be read with a voltmeter (\rightarrow pin assignment, "Electrical Connection"). The desired threshold setting can be determined with the formula or the diagram "Output Signal vs. Pressure". If the actual pressure is lower than the set threshold, the corresponding LED (STP1 or STP2) is lit and the corresponding relay is activated (\rightarrow "Electrical Connection" and "Relay Functions").

Relay Functions

The gauge is equipped with five change-over relays (\rightarrow "Electrical Connection") that can be used for monitoring the gauge and controlling a process. The status of a relay is indicated by the corresponding LED (\rightarrow "Status Indicators"). The relay status is output at the D-Sub connector (\rightarrow pin assignment, "Electrical Connection").

Deinstallation

STOP DANGER



Caution: contaminated parts

Contaminated parts can be detrimental to health and environment.

Before beginning to work, find out whether any parts are contaminated. Adhere to the relevant regulations and take the necessary precautions when handling contaminated parts.

Caution



Caution: vacuum component

Dirt and damages impair the function of the vacuum component.

When handling vacuum components, take appropriate measures to ensure cleanliness and prevent damages.

Caution



Caution: dirt sensitive area

Touching the product or parts thereof with one's bare hands increases the desorption rate.

Always wear clean, lint-free gloves and use clean tools when working in this area.

- 1 Vent the vacuum system.
- 2 Turn the gauge off.
- 3 Loosen the lock screws and unplug the sensor cable.
- 4 Remove the gauge from the vacuum system.

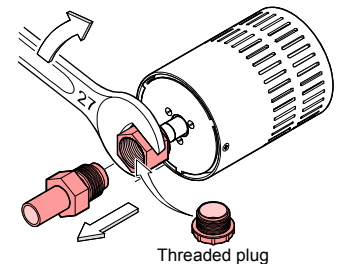

Maintenance, Repair

Under clean operating conditions, the product requires no maintenance.

- Gauge failures due to contamination are not covered by the warranty. INFICON assumes no liability and the warranty becomes null and void if any repair work is carried out by the end-user or third parties.

Returning the Product

WARNING



Caution: forwarding contaminated products Contaminated products (e.g. radioactive, toxic, caustic or microbiological hazard) can be detrimental to health and environment. Products returned to INFICON should preferably be free of harmful substances. Adhere to the forwarding regulations of all involved countries and forwarding companies and enclose a duly completed declaration of contamination.

Products that are not clearly declared as "free of harmful substances" are decontaminated at the expense of the customer.

Products not accompanied by a duly completed declaration of contamination are returned to the sender at his own expense.

Disposal

DANGER



Caution: contaminated parts Contaminated parts can be detrimental to health and environment. Before beginning to work, find out whether any parts are contaminated. Adhere to the relevant regulations and take the necessary precautions when handling contaminated parts.

WARNING



Caution: substances detrimental to the environment Products or parts thereof (mechanical and electric components, operating fluids etc.) can be detrimental to the environment. Dispose of such substances in accordance with the relevant local regulations.

Separating the Components

After disassembling the product, separate its components according to the following criteria:

- Contaminated components Contaminated components (radioactive, toxic, caustic, or biological hazard etc.) must be decontaminated in accordance with the relevant national regulations, separated according to their materials, and disposed of.
- Other components Such components must be separated according to their materials and recycled.

Declaration of Contamination

The service, repair, and/or disposal of vacuum equipment and components will only be carried out if a correctly completed declaration has been submitted. Non-completion will result in delay. This declaration may only be completed (in block letters) and signed by authorized and qualified staff.

- 1 Description of product**
 Type _____
 Part number _____
 Serial number _____
- 2 Reason for return**

- 3 Operating fluid(s) used**
 (Must be drained before shipping.)

- 4 Process related contamination of product**

toxic	no <input type="checkbox"/> 1)	yes <input type="checkbox"/>	 <p>2) Products thus contaminated will not be accepted without written evidence of decontamination!</p>
corrosive	no <input type="checkbox"/> 1)	yes <input type="checkbox"/>	
biological hazard	no <input type="checkbox"/>	yes <input type="checkbox"/> 2)	
explosive	no <input type="checkbox"/>	yes <input type="checkbox"/> 2)	
radioactive	no <input type="checkbox"/>	yes <input type="checkbox"/> 2)	
other harmful substances	no <input type="checkbox"/> 1)	yes <input type="checkbox"/>	

1) or not containing any amount of hazardous residues that exceed the permissible exposure limits

The product is free of any substances which are damaging to health yes
- 5 Harmful substances, gases and/or by-products**
 Please list all substances, gases, and by-products which the product may have come into contact with:

Trade/product name Manufacturer	Chemical name (preferably with formula)

Precautions associated with substance	Action in case of human contact
- 6 Legally binding declaration:**
 We hereby declare that the information on this form is complete and accurate and that we will assume any further costs that may arise. The contaminated product will be dispatched in accordance with the applicable regulations.

Organization/company _____
 Address _____
 Post code, place _____
 Phone _____ Fax _____
 E-mail _____
 Name _____

Company stamp _____

Date and legally binding signature _____

This form can be downloaded from our website.
 Copies: Original for addressee
 1 copy for accompanying documents
 1 copy for file of sender

Declaration of Conformity



We, INFICON, hereby declare that the equipment mentioned below complies with the provisions of the Directive relating to electrical equipment designed for use within certain voltage limits 73/23/EEC and the Directive relating to electromagnetic compatibility 89/336/EEC.

SKY™ Capacitance Diaphragm Gauge CDG160-S

Part numbers

373-060	373-065
373-061	373-066
373-062	373-067
373-063	373-068

Standards

Harmonized and international/national standards and specifications:

- EN 61010 (Safety requirements for electrical equipment for measurement, control and laboratory use)
- EN 50081-1 (Electromagnetic compatibility: generic emission standard)
- EN 50082-2 (Electromagnetic compatibility: generic immunity standard)

Signatures

INFICON AG, Balzers

6 August 2001

Hannes Fischer
Product Manager

6 August 2001

Dr. Georg Sele
Technical Support Manager
Quality Representative



LI-9496 Balzers
Liechtenstein
Tel +423 / 388 3111
Fax +423 / 388 3700
reach.liechtenstein@inficon.com
www.inficon.com