

Bayard-Alpert Pirani Gauge

Dual Filament Bayard-Alpert Pirani Gauge

BPG402-S
BPG402-SD
BPG402-SP

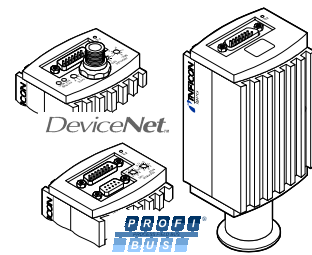

Instruction Sheet
Incl. Declaration of Conformity

tima46e1-a (2006-07)

Product Identification

In all communications with INFICON, please specify the information given on the product nameplate. For convenient reference copy that information into the space provided below.

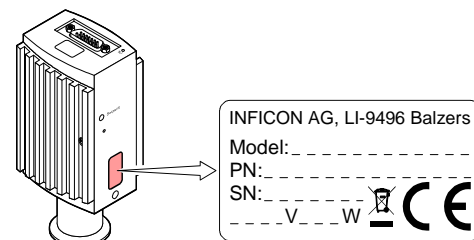

Validity

This document applies to products with the following part numbers:

BPG402-S (without display, 1 switching function)
353-570 (vacuum connection DN 25 ISO-KF)
353-571 (vacuum connection DN 40 CF-R)

BPG402-S (with display, 1 switching function)
353-572 (vacuum connection DN 25 ISO-KF)
353-573 (vacuum connection DN 40 CF-R)

BPG402-SD (with DeviceNet interface and 2 switching functions)
353-576 (vacuum connection DN 25 ISO-KF)
353-577 (vacuum connection DN 40 CF-R)

BPG402-SP (with Profibus interface and 2 switching functions)
353-574 (vacuum connection DN 25 ISO-KF)
353-575 (vacuum connection DN 40 CF-R)

The part number (PN) can be taken from the product name plate.

If not indicated otherwise in the legends, the illustrations in this document correspond to the gauge with part number 353-572. They apply to the other gauges by analogy (more detailed information on BPG402-SD and -SP gauges → [1] and [2]).

We reserve the right to make technical changes without prior notice.

All dimensions in mm.

Intended Use

The BPG402-S, BPG402-SD and -SP gauges have been designed for vacuum measurement of non-flammable gases and gas mixtures in a pressure range 5×10^{-10} ... 1000 mbar.

The gauges can be operated in connection with the VGC 40x Vacuum Gauge Controller or with another instrument or control device.

Functional Principle

Over the whole measuring range, the gauge has a continuous characteristic curve and its measuring signal is output as logarithm of the pressure.

The gauge functions with a Bayard-Alpert hot cathode ionization measurement system (for $p < 2.0 \times 10^{-2}$ mbar) and a Pirani measurement system (for $p > 5.5 \times 10^{-3}$ mbar). In the overlapping pressure range of 2.0×10^{-2} ... 5.5×10^{-3} mbar, a mixed signal of the two measurement systems is output. The hot cathode is switched on by the Pirani measurement system only below the switching threshold of 2.4×10^{-2} mbar (to prevent filament burn-out). It is switched off when the pressure exceeds 3.2×10^{-2} mbar.

BPG402-Sx sensors are equipped with two hot cathodes. The filaments are monitored by the gauge electronics. In case of a filament failure, the gauge will switch over to the second (undamaged) filament and continue to operate. Filament status is displayed on the gauge or can be read via the interfaces).

The gauge features an adjustable switching function (setpoint) (→ [1] for full description).

Safety

Symbols Used

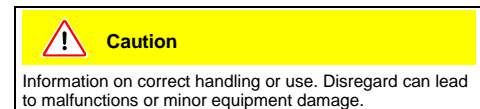
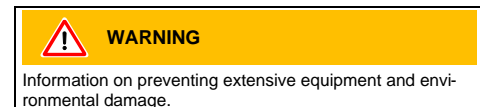
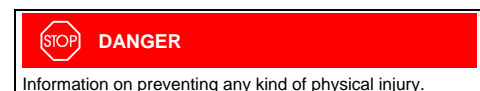

Personnel Qualifications

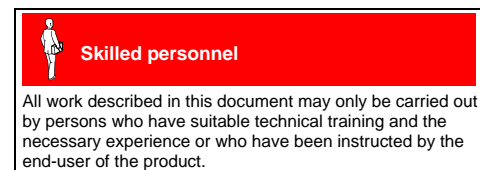

General Safety Instructions

- Adhere to the applicable regulations and take the necessary precautions for the process media used. Consider possible reactions with the product materials. Consider possible reactions (e.g. explosion) of the process media due to the heat generated by the product.

- Adhere to the applicable regulations and take the necessary precautions for all work you are going to do and consider the safety instructions in this document.

- Before beginning to work, find out whether any vacuum components are contaminated. Adhere to the relevant regulations and take the necessary precautions when handling contaminated parts.

Communicate the safety instructions to all other users.

Liability and Warranty

INFICON assumes no liability and the warranty becomes null and void if the end-user or third parties

- disregard the information in this document
- use the product in a non-conforming manner
- make any kind of changes (modifications, alterations etc.) to the product
- use the product with accessories not listed in the product documentation.

The end-user assumes the responsibility in conjunction with the process media used.

Gauge failures due to contamination, as well as expendable parts (filament), are not covered by the warranty.

Technical Data

In some points, the technical data of BPG402-SD and -SP differ from those of BPG402-S, which are given below (→ "Technical Data" in [1] and [2]).

Measuring range (air, O ₂ , CO, N ₂)	5 × 10 ⁻¹⁰ ... 1000 mbar continuous
Accuracy (after 10 min. stabilization)	15% of reading in the range of 1 × 10 ⁻⁸ ... 10 ⁻² mbar
Repeatability (after 10 min. stabilization)	5% of reading in the range of 1 × 10 ⁻⁸ ... 10 ⁻² mbar

Emission	
Switching on threshold	2.4 × 10 ⁻² mbar
Switching off threshold	3.2 × 10 ⁻² mbar
Emission current	
$p \leq 7.2 \times 10^{-6}$ mbar	5 mA
7.2×10^{-6} mbar < $p < 3.2 \times 10^{-2}$ mbar	25 µA
Emission current switching	
25 µA ⇒ 5 mA	7.2 × 10 ⁻⁶ mbar
5 mA ⇒ 25 µA	3.0 × 10 ⁻³ mbar
Filaments	
Number	2
Means of selection	Controlled by gauge (default) or via interfaces (→ [1])

Settling time of measuring signal after filament change	<4s
Filament status	LED, relay contact
Emission control mode	
Automatic	Emission ON/OFF automatically
Manual	Emission ON/OFF by user via interfaces (→ [1])

Degas	
Current ($p < 7.2 \times 10^{-6}$ mbar)	≈20 mA
Control input signal	0 V/+24 V, active high
Duration	<3 min, followed by automatic stop

In degas mode, the BPG402-Sx keeps supplying pressure readings, the tolerances of which can be higher than during normal operation.

Output signal (measuring signal)	0 ... +10 V
Measuring range	+0.774 ... +10 V (5 × 10 ⁻¹⁰ ... 1000 mbar) logarithmic, 0.75 V/decade
Voltage vs. pressure	
Error signal (→ [1])	
EEPROM error	≈+0.1 VDC
Hot cathode error	≈+0.3 VDC
Pirani error	≈+0.5 VDC
Minimum load impedance	10 kΩ

Gauge identification	42 kΩ (Pin 10 and Pin 5 on sensor cable connector)
----------------------	--

Switching function	
Adjustment range	1 × 10 ⁻⁹ mbar ... 100 mbar Setpoint adjustable via potentiometer, one floating, normally open relay contact (→ "Electrical Connection")
Hysteresis	10% of reading
Relay contact rating	≤60 V, ≤0.5 ADC

RS232C interface	
Data rate, data format	9600 baud, binary, 8 data bits, 1 stop bit
Connector	no parity bit, no handshake (→ "Electrical Connection")

Further information on the RS232C interface → [1]

Display (353-572, 353-573)	LCD matrix, 32 × 16 pixels, with background illumination
Dimensions	17 mm × 12 mm
Pressure units	mbar (default), Torr, Pa
Selecting the pressure unit	via RS232C → [1]

Supply

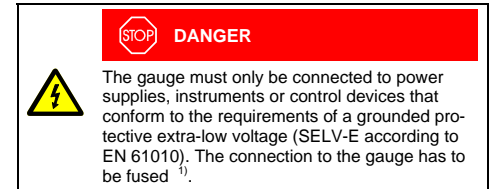

Voltage at gauge	+24 VDC (+20 ... +28 VDC) (ripple ≤2 V _{pp}) ²⁾
Power consumption	
Standard	≤0.5 A
Degas	≤0.8 A
Emissions start (200 ms)	≤1.4 A
Fuse required ¹⁾	≤1.25 AT
Power consumption	≤18 W (BPG402-S only)

Electrical connection	D-Sub, 15 pins, male
Sensor cable	Shielded, number of conductors depend on functions used.

Cable length (24 VDC)	≤35 m (0.25 mm ² /conductor) ≤50 m (0.34 mm ² /conductor) ≤100 m (1.0 mm ² /conductor)
-----------------------	---

For operation with RS232C interface	≤30 m
-------------------------------------	-------

Materials on the vacuum side	
Housing, supports, screens	stainless steel
Feedthroughs	NiFe nickel plated
Insulator	glass
Cathode	iridium, yttrium oxide (Y ₂ O ₃)
Cathode holder	molybdenum, platinum
Pirani element	tungsten, copper

Internal volume	
DN 25 ISO-KF	≈24 cm ³
DN 40 CF-R	≈34 cm ³
Pressure max.	≤2 bar (absolute)

Admissible temperatures	
Storage	-20 ... +70 °C
Operation	0 ... +50 °C
Bakeout	80 °C (flange temperature, without electronics unit, horizontally mounted)

Relative humidity	
Year's mean	≤65% (not condensable)
During 60 days	≤85% (not condensable)
Use	indoors only altitude up to 2000 m NN

Mounting orientation	any
Type of protection	IP 30

- INFICON controllers fulfill these requirements.
- Consider the voltage drop on the sensor cable.

Dimensions

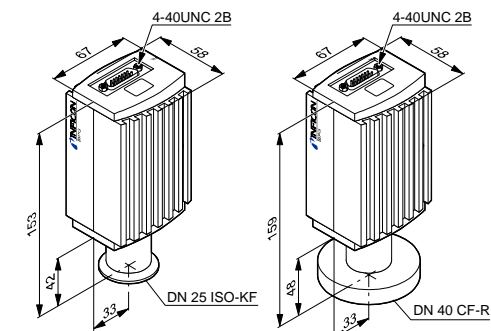

Weight:	353-570, 353-572	≈450 g
	353-571, 353-573	≈710 g

Measuring Signal vs. Pressure

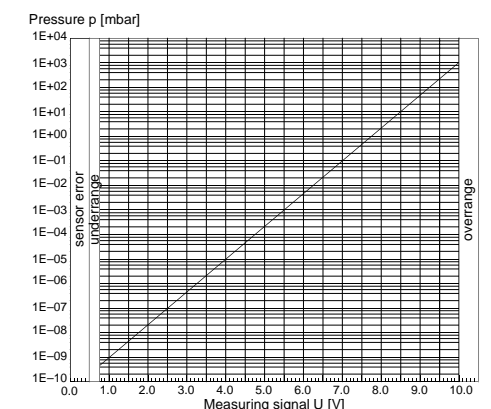

$$p = 10^{(U-7.75)/0.75+c}$$

U	p	c
[V]	[mbar]	0
[V]	[Pa]	2
[V]	[Torr]	-0.125

where p pressure
U measuring signal
c constant (pressure unit dependent)

Gas Type Dependence

For gases other than air, the pressure in the indication range $p < 10^{-3}$ mbar can be determined by a simple conversion:

$$p_{\text{eff}} = C \times \text{pressure indicated}$$

Gas type	Calibration factor C	Gas type	Calibration factor C
He	5.9	air, O ₂ , CO, N ₂	1.0
Ne	4.1	H ₂	2.4
Kr	0.5	Xe	0.4
Ar	0.8		

Installation

Vacuum Connection

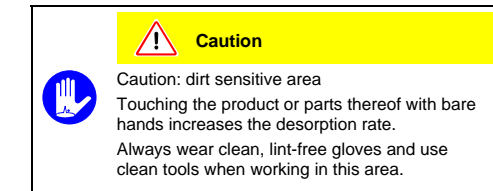
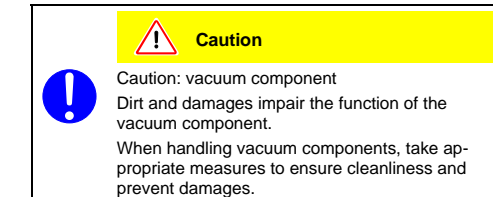
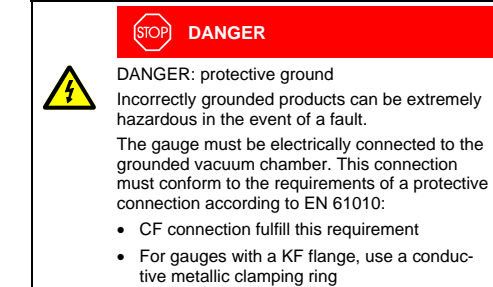
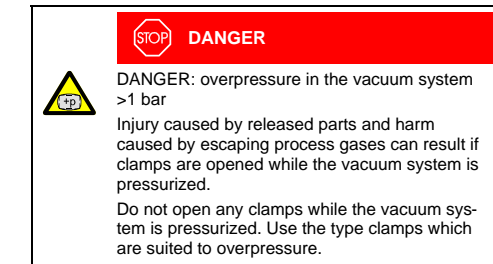

The gauge may be mounted in any orientation. To keep condensates and particles from getting into the measuring chamber, preferably choose a horizontal to upright position.
The gauge is supplied with a built-in grid. For potentially contaminating applications and to protect the electrodes against light and fast particles, installation of the optional baffle is recommended (→ [1]).

Vacuum connection free of grease.

Remove the protective lid and install the gauge to the vacuum system.

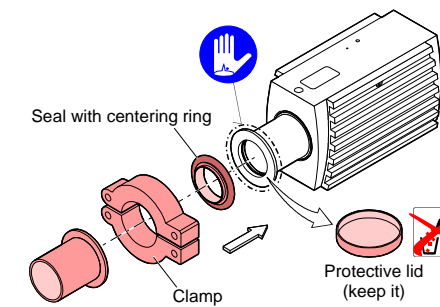

Electrical Connection (BPG402-S only)

Make sure the vacuum connection is properly made (→ "Vacuum Connection").

If no connection cable is available, make one according to the following diagram.

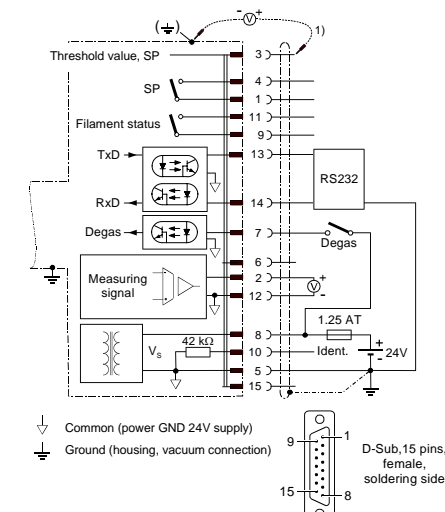

Electrical connection

Pin 1	Relay switching function, common contact	
Pin 2	Measuring signal output	0 ... +10 V
Pin 3	Threshold (setpoint) ¹⁾	0 ... +10 V
Pin 4	Relay switching function, n.o. contact	
Pin 5	Supply common	0 V
Pin 6	Not connected internally	
Pin 7	Degas (active high)	0 V/+24 V
Pin 8	Supply (V _s)	+24 V
Pin 9	Relay filament status common contact ²⁾	
Pin 10	Gauge identification	
Pin 11	Relay filament status, n.o. contact ²⁾	
Pin 12	Measuring signal common	
Pin 13	RS232C, Tx/D	
Pin 14	RS232C, Rx/D	
Pin 15	Do not connect	

¹⁾ Do not connect pin 3 for normal operation of the gauge. This pin is reserved for adjustment of the setpoint potentiometer (→ section "Switching Function").

²⁾ → section "Filament Status"



- 2 Connect the sensor cable to the gauge.
- 3 Secure the cable connector with the lock screws.
- 4 Connect the sensor cable to the controller.

A "Filament Status" relay contact is available at the sensor cable connector → "Electrical Connection" (pins 9 and 11).

Filament status	Relay contact
Both filaments O.K.	energized
One filament broken	deenergized
Both filaments broken	deenergized

Switching Function

The BPG402-S has a manually adjustable switching function with a normally open relay contact. The relay contact is accessible at the sensor cable connector (pins 1 and 4).

The threshold value of the switching function can be set within the pressure range 1×10^{-9} mbar ... 100 mbar via a potentiometer "SETPOINT".

The following rule applies:

$$U_{\text{Threshold}} = 0.75 \times (\log p_{\text{Setpoint}} - c) + 7.75$$

Where constant c is pressure unit dependent (→ "Relationship Measuring Signal – Pressure").

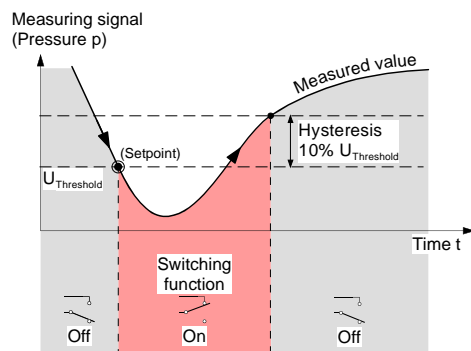

Setting the Switching Function

- 1 Put the gauge into operation.
- 2 Connect the + lead of a voltmeter to the threshold measurement point Pin 3 and its – lead to a grounded point (e.g. connector case or flange of the gauge).

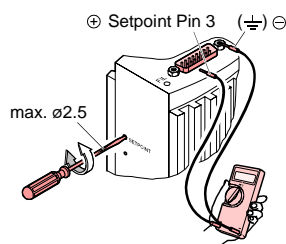

- 3 Using a screwdriver (max. ø2.5 mm), set the voltage (Setpoint) to the desired value $U_{\text{Threshold}}$.

Deinstallation

STOP DANGER

DANGER: contaminated parts
Contaminated parts can be detrimental to health and environment.
Before beginning to work, find out whether any parts are contaminated. Adhere to the relevant regulations and take the necessary precautions when handling contaminated parts.

Caution

Caution: vacuum component
Dirt and damages impair the function of the vacuum component.
When handling vacuum components, take appropriate measures to ensure cleanliness and prevent damages.

Gas Type Dependence

The measurement value is gas dependent. The displayed reading applies to dry air, O₂, CO, and N₂. For other gases, it has to be converted (→ "Technical Data" and [1]).

Display

(BPG402-S with part numbers 353-572 and 353-573)

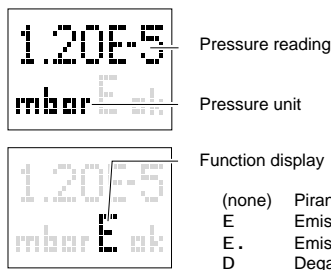

Error display:
1.20E-5 mbar **OK**
No error (green background illumination)

FAIL Pir
Pirani sensor error (red background illumination)

FAIL Ion
Bayard-Alpert sensor error (red background illumination)

NO Signal
Internal data connection failure (red background illumination)

Filament Status

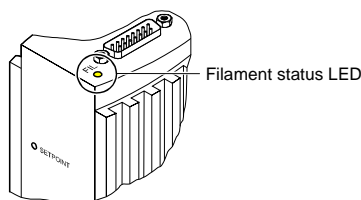

Filament status	Emission	Status LED
–	off	dark
Both filaments O.K.	on	green
One filament broken	on	green, flashing
Both filaments broken	on	red

Caution

Caution: dirt sensitive area
Touching the product or parts thereof with bare hands increases the desorption rate.
Always wear clean, lint-free gloves and use clean tools when working in this area.

- 1 Vent the vacuum system.
- 2 Turn the gauge off at the power supply.
- 3 Unfasten the lock screws and unplug the sensor cable. (If you are using BPG402-SD or -SP, unfasten and unplug the interface cable, too (→ [1] and [2]).
- 4 Remove the gauge from the vacuum system and install the protective lid.

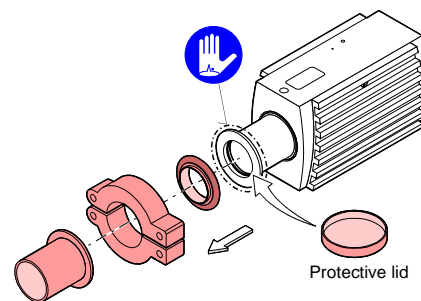

Maintenance, Troubleshooting

In case of severe contamination or a malfunction, the sensor can be replaced (→ [1]).

Gauge failures due to contamination, as well as expendable parts (filament), are not covered by the warranty.

Adjusting the Gauge

The gauge is factory calibrated. If used under different climatic conditions, at extreme temperatures, through aging or contamination and after exchanging the sensor, the characteristic curve can be offset and readjustment can become necessary. Only the Pirani element can be adjusted and only at atmosphere.

At the push of a button the digital value and thus the analog output are adjusted electronically to +10 V at atmospheric pressure.

Adjustment is necessary if

- at atmospheric pressure, the output signal is $< +10$ V
- the display reads $<$ atmospheric pressure (if the gauge has a display)
- at atmosphere, the digital value of the RS232C interface is $<$ atmospheric pressure
- when the vacuum system is vented, the digital value of the RS232C interface reaches its maximum before the measured pressure has reached atmosphere.

- 1 Activate the gauge and operate it for ≈ 10 minutes at atmospheric pressure. If the gauge was operated within the Bayard-Alpert range, a cooling-down time of ≈ 30 minutes is to be expected.
- 2 Press the button with a pin (max. ø1.3 mm) for 1 s.

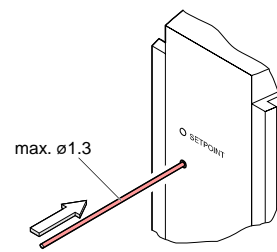

Gauges with a display will show the reading "1000 mbar".

Zero Point Adjustment

Zero point readjustments are automatically carried out during operation of the gauge, no manual adjustment is needed.

Returning the Product

WARNING

WARNING: forwarding contaminated products
Contaminated products (e.g. radioactive, toxic, caustic or microbiological hazard) can be detrimental to health and environment.
Products returned to INFICON should preferably be free of harmful substances. Adhere to the forwarding regulations of all involved countries and forwarding companies and enclose a duly completed declaration of contamination

Products that are not clearly declared as "free of harmful substances" are decontaminated at the expense of the customer.

Products not accompanied by a duly completed declaration of contamination are returned to the sender at his own expense.

Disposal

STOP DANGER

DANGER: contaminated parts
Contaminated parts can be detrimental to health and environment.
Before beginning to work, find out whether any parts are contaminated. Adhere to the relevant regulations and take the necessary precautions when handling contaminated parts.

WARNING

WARNING: substances detrimental to the environment
Products or parts thereof (mechanical and electric components, operating fluids etc.) can be detrimental to the environment.
Dispose of such substances in accordance with the relevant local regulations.

Separating the components

After disassembling the product, separate its components according to the following criteria:

- Contaminated components
Contaminated components (radioactive, toxic, caustic, or biological hazard etc.) must be decontaminated in accordance with the relevant national regulations, separated according to their materials, and recycled.
- Other components
Such components must be separated according to their materials and recycled.

Further Information

- [1] www.inficon.com
Operating Manual tina46e1
Bayard-Alpert Pirani Gauge BPG402-S, BPG402-SD, BPG402-SP
INFICON AG, LI-9496 Balzers, Liechtenstein
- [2] www.inficon.com
Instruction Sheet tima47e1
Bayard-Alpert Pirani Gauge BPG402-SD, BPG402-SP
INFICON AG, LI-9496 Balzers, Liechtenstein

Declaration of Contamination

The service, repair, and/or disposal of vacuum equipment and components will only be carried out if a correctly completed declaration has been submitted. Non-completion will result in delay. This declaration may only be completed (in block letters) and signed by authorized and qualified staff.

- Description of product**
Type _____
Part number _____
Serial number _____
- Reason for return**

- Operating fluid(s) used**
(Must be drained before shipping.)

- Used in copper process**
no yes Seal product in plastic bag and mark it with a corresponding label.
- Process related contamination of product:**

toxic	no <input type="checkbox"/> 1)	yes <input type="checkbox"/>
corrosive	no <input type="checkbox"/> 1)	yes <input type="checkbox"/>
biological hazard	no <input type="checkbox"/>	yes <input type="checkbox"/> 2)
explosive	no <input type="checkbox"/>	yes <input type="checkbox"/> 2)
radioactive	no <input type="checkbox"/>	yes <input type="checkbox"/> 2)
other harmful substances	no <input type="checkbox"/> 1)	yes <input type="checkbox"/>

1) or not containing any amount of hazardous residues that exceed the permissible exposure limits
2) Products thus contaminated will not be accepted without written evidence of decontamination.
- Harmful substances, gases and/or by-products**
Please list all substances, gases, and by-products which the product may have come into contact with:
Trade/product name manufacturer _____ Chemical name (or symbol) _____
Precautions associated with substance _____ Action if human contact _____
- Legally binding declaration:**
We hereby declare that the information on this form is complete and accurate and that we will assume any further costs that may arise. The contaminated product will be dispatched in accordance with the applicable regulations.
Organization/company _____
Address _____
Post code, place _____
Phone _____ Fax _____
Email _____
Name _____
Company stamp _____

This form can be downloaded from our website.
Copies: Original for addressee
1 copy for accompanying documents
1 copy for file of sender

Declaration of Conformity

CE We, INFICON, hereby declare that the equipment mentioned below complies with the provisions of the Directive relating to electrical equipment designed for use within certain voltage limits 73/23/EEC and the Directive relating to electromagnetic compatibility 89/336/EEC.

Bayard-Alpert Pirani Gauge

Dual Filament Bayard-Alpert Pirani Gauge
BPG402-S
BPG402-SD
BPG402-SP

Part numbers

353-570
353-571
353-572
353-573
353-574
353-575
353-576
353-577

Standards

Harmonized and international/national standards and specifications:

- EN 61010-1 (Safety requirements for electrical equipment for measurement, control and laboratory use)
- EN 61000-6-2 (Electromagnetic compatibility generic immunity standard)
- EN 61000-6-3 (Electromagnetic compatibility generic emission standard)
- EN 50325 (DeviceNet standard)
- EN 50170 (Profibus standard)

Signatures

INFICON AG, Balzers
30 November 2004
30 November 2004
Michael Schöch
Product Marketing Manager
Dr. Georg Sele
Technical Support Manager
Quality Representative