

# TripleGauge™

Bayard-Alpert Pirani Capacitance Diaphragm Gauge

BCG450  
BCG450-SD  
BCG450-SP

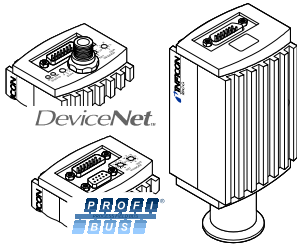

Instruction Sheet  
Incl. Declaration of Conformity  
tima40e1-a (2005-04)

## Product Identification

In all communications with INFICON, please specify the information given on the product nameplate. For convenient reference copy that information into the space provided below.

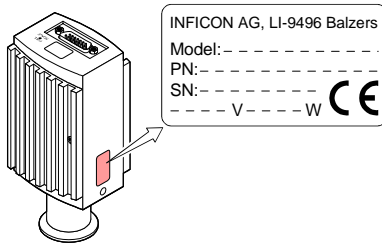

## Validity

This document applies to products with the following part numbers (PN):

BCG450 (without display)  
353-550 (DN 25 ISO-KF)  
353-551 (DN 40 CF-R)

BCG450 (with display)  
353-552 (DN 25 ISO-KF)  
353-553 (DN 40 CF-R)

BCG450-SD (with DeviceNet interface and switching functions)  
353-557 (DN 25 ISO-KF)  
353-558 (DN 40 CF-R)

BCG450-SP (with Profibus interface and switching functions)  
353-554 (DN 25 ISO-KF)  
353-556 (DN 40 CF-R)

The part number (PN) can be taken from the product name plate.

If not indicated otherwise in the legends, the illustrations in this document correspond to the gauge with part number 353-550. They apply to the other gauges by analogy.

We reserve the right to make technical changes without prior notice.

All dimensions in mm.

## Intended Use

The BCG450, BCG450-SD and BCG450-SP gauges have been designed for vacuum measurement of non-flammable gases and gas mixtures in a pressure range  $5 \times 10^{-10}$  ... 1500 mbar.

## Trademarks

DeviceNet™ Open DeviceNet Vendor Association, Inc.  
TripleGauge™ INFICON AG, Balzers

## Functional Principle

Due to the combination of three sensor technologies incorporated in the gauge (Capacitance diaphragm sensor, Pirani sensor and hot cathode ionisation sensor (BA)), a minimized gas type dependence is achieved.

Between 10 mbar and atmospheric pressure, the capacitance diaphragm sensor operates without any gas type dependence. Below 1 mbar, the Pirani sensor and the hot cathode ionisation sensor take over with only a small gas type dependence.

Between  $1 \dots 10$  mbar and  $5 \times 10^{-3} \dots 2 \times 10^{-2}$  mbar the gauges built in electronic circuits take care of continuous and smooth crossovers between the ranges. Over the whole measurement range, the measurement signal is output as a logarithm of the pressure.

The hot cathode is switched on by the Pirani measurement system only below the switching threshold of  $2.4 \times 10^{-2}$  mbar (to prevent filament burn-out). It is switched off when the pressure exceeds  $3.2 \times 10^{-2}$  mbar.

Gauge adjustment is carried out automatically, no manual adjustment is required.

A user programmable atmospheric pressure switching function is incorporated.

## Safety

### Symbols Used

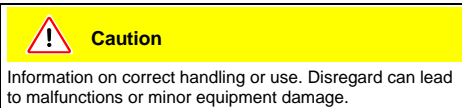
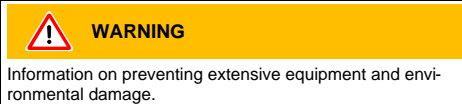
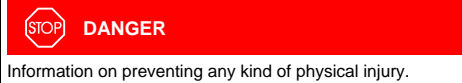

## Personnel Qualifications

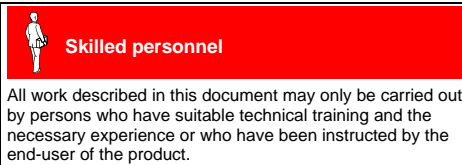

## General Safety Instructions

- Adhere to the applicable regulations and take the necessary precautions for the process media used. Consider possible reactions with the product materials. Consider possible reactions (e.g. explosion) of the process media due to the heat generated by the product.
- Adhere to the applicable regulations and take the necessary precautions for all work you are going to do and consider the safety instructions in this document.
- Before beginning to work, find out whether any vacuum components are contaminated. Adhere to the relevant regulations and take the necessary precautions when handling contaminated parts.

Communicate the safety instructions to all other users.

## Liability and Warranty

INFICON assumes no liability and the warranty becomes null and void if the end-user or third parties

- disregard the information in this document
- use the product in a non-conforming manner
- make any kind of changes (modifications, alterations etc.) to the product
- use the product with accessories not listed in the product documentation.

The end-user assumes the responsibility in conjunction with the process media used.

## Technical Data



In some points, the technical data of BCG450-SD and BCG450-SP differ from those of BCG450, which are given below (→ "Technical Data" in [1] and [2]).

Measuring principle	10 ... 1500 mbar	capacitance diaphragm sensor
	1 ... 10 mbar	crossover range
	$2 \times 10^{-2}$ ... 1 mbar	Pirani sensor
	$5 \times 10^{-3}$ ... $2 \times 10^{-2}$ mbar	crossover range
	$5 \times 10^{-10}$ ... $5 \times 10^{-3}$ mbar	hot cathode ionization (BA)
Measuring range (air, O <sub>2</sub> , CO, N <sub>2</sub> )		$5 \times 10^{-10}$ ... 1500 mbar continuous
Accuracy		
	$1 \times 10^8$ ... 50 mbar	15% of reading
	50 ... 950 mbar	5% of reading
	950 ... 1050 mbar	2.5% of reading (after 10 min. stabilization)
Repeatability ( $1 \times 10^8$ ... $10^2$ mbar)		5% of reading (after 10 min. stabilization)
Emission		
Switching on threshold		$2.4 \times 10^{-2}$ mbar
Switching off threshold		$3.2 \times 10^{-2}$ mbar
Emission current		
$p \leq 7.2 \times 10^6$ mbar		5 mA
$7.2 \times 10^6$ mbar < $p < 3.2 \times 10^2$ mbar		25 $\mu$ A
Emission current switching		
25 $\mu$ A $\Rightarrow$ 5 mA		$7.2 \times 10^6$ mbar
5 mA $\Rightarrow$ 25 $\mu$ A		$3.0 \times 10^{-5}$ mbar
Degas		
Current ( $p < 7.2 \times 10^6$ mbar)		$\approx 20$ mA ( $P_{\text{degas}} \approx 4.0$ W)
Control input signal		0 V/+24 V, active high
Duration		<3 min, followed by automatic stop. A new degas cycle can only be started after a waiting time of 30 minutes.
		In degas mode, the BCG450 keeps supplying pressure readings, the tolerances of which can be higher than during normal operation.
Output signal (measuring signal)		0 ... +10.13 V
Measuring range		0.774 V $\pm$ $5 \times 10^{-10}$ mbar ... 10.13 V $\pm$ 1500 mbar
Relationship voltage-pressure		logarithmic, 0.75 V/decade
Error signal (→ [1])		+0.1 V diaphragm sensor error or EEPROM error
		+0.3 V BA sensor error
		+0.5 V Pirani sensor error
Minimum load impedance		10 k $\Omega$
Gauge identification		42 k $\Omega$ between Pin 10 and Pin 5 (gauge cable connector)
Atmosphere switching function (relay "Atmosphere reached")		Atmospheric pressure threshold programmable via serial interfaces (→ [1])
BCG450		threshold value programmable via RS232 (default value 99%)
BCG450-SD/-SP		threshold value programmable via fieldbus interfaces (→ corresponding communication protocols).
RS232C interface (BCG450)		
Data rate		9600 Baud
Data format		binary
		8 data bits
		one stop bit
		no parity bit
		no handshake
Connector		→ "Electrical Connection"
Further information on the RS232C interface		→ [1]
Display (353-552, 353-553)		LCD matrix, 32x16 pixels
Background illumination		two colors red/green
Dimensions		16.0 mm x 11.2 mm
Pressure units		mbar (default), Torr, Pa (Selecting the pressure unit → [1])

**Supply**

<b>STOP DANGER</b>	
	The gauge must only be connected to power supplies, instruments or control devices that conform to the requirements of a grounded protective extra-low voltage (SELV-E according to EN 61010). The connection to the gauge has to be fused <sup>1)</sup> .
Voltage at gauge	+24 VDC (+20 ... +28 VDC) (ripple $\leq 2 V_{pp}$ ) <sup>2)</sup>
Power consumption	
Standard	$\leq 0.5$ A
Degas	$\leq 0.9$ A
Emissions start (200 ms)	$\leq 1.4$ A
Fuse required <sup>1)</sup>	1.25 AT
Power consumption	$\leq 18$ W (BPG450)
Electrical connection	D-Sub, 15 pins, male
Sensor cable	shielded, number of conductors depending on the functions used (max. 15 conductors plus shielding).
Cable length (24 VDC (conductor cross-section))	$\leq 35$ m (0.25 mm <sup>2</sup> ) $\leq 50$ m (0.34 mm <sup>2</sup> ) $\leq 100$ m (1.0 mm <sup>2</sup> )
For operation with RS232C interface	$\leq 30$ m

Materials on the vacuum side	
Housing, supports, screens	stainless steel
Feedthroughs	NiFe nickel plated
Insulator	glass
Cathode	iridium, yttrium oxide (Y <sub>2</sub> O <sub>3</sub> )
Cathode holder	molybdenum
Pirani element	tungsten, copper
diaphragm	ceramic (Al <sub>2</sub> O <sub>3</sub> )
sensor electrodes	SnAg
Internal volume	
DN 25 ISO-KF	$\approx 24$ cm <sup>3</sup>
DN 40 CF-R	$\approx 34$ cm <sup>3</sup>
Maximum admissible pressure	5 bar (absolute)
Admissible temperatures	
Storage	-20 ... +70 °C
Operation	0 ... +50 °C
Bakeout	+80 °C (at vacuum connection, without electronics unit, horizontally mounted)
Relative humidity	
Year's mean	$\leq 65\%$ (not condensable)
During 60 days	$\leq 85\%$ (not condensable)
Use	indoors only altitude up to 2000 m NN
Mounting orientation	any
Type of protection	IP 30

**Dimensions [mm]**

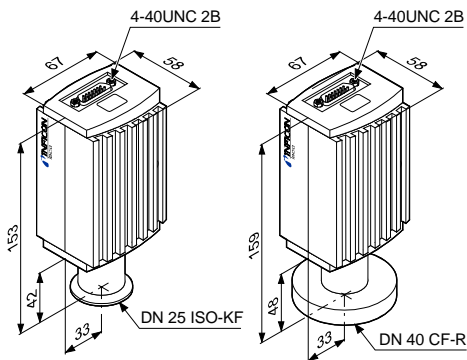

Weight	
353-550, 353-552	$\approx 305$ g
353-551, 353-553	$\approx 565$ g
353-554, 353-557	$\approx 445$ g
353-556, 353-558	$\approx 710$ g

**Relationship Measuring Signal – Pressure**

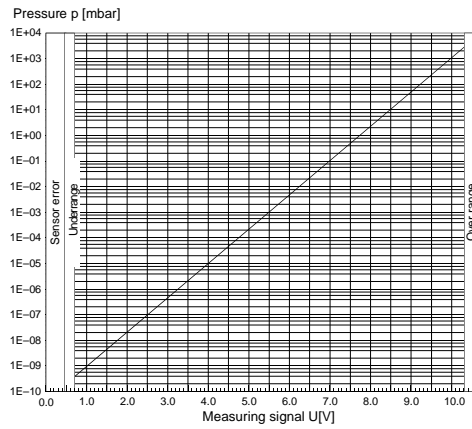

$$p = 10^{(U-7.75)/0.75+c}$$

U [V]	p [mbar]	c
0	0	0
2	1 Pa	2
-0.125	1 Torr	-0.125

where p pressure  
U measuring signal  
c constant (pressure unit dependent)

**Gas Type Dependence**

Indicated pressure (gauge calibrated for air)

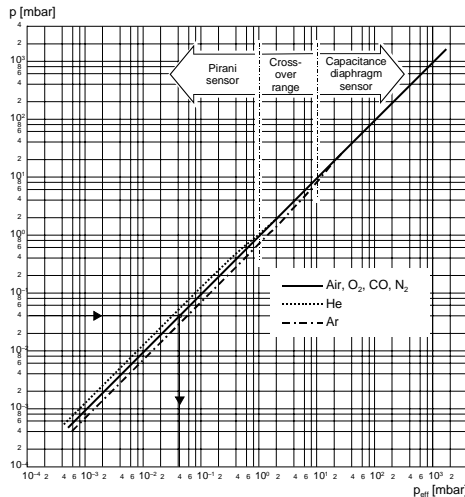

**Calibration factors**

(Gauge calibrated for air)

$$p_{eff} = C \times \text{pressure indicated}$$

Valid for Pirani pressure range  $2 \times 10^{-2}$  ... 1 mbar:

Gas type	Calibration factor C	Gas type	Calibration factor C
He	0.8	H <sub>2</sub>	0.5
Ne	1.4	air, O <sub>2</sub> , CO, N <sub>2</sub>	1.0
Ar	1.7	CO <sub>2</sub>	0.9
Kr	2.4	H <sub>2</sub> O vapor	0.5
Xe	3.0	freon 12	0.7

Valid for BA pressure range  $\leq 5 \times 10^{-3}$  mbar:

Gas type	Calibration factor C	Gas type	Calibration factor C
He	5.9	H <sub>2</sub>	2.4
Ne	4.1	air, O <sub>2</sub> , CO, N <sub>2</sub>	1.0
Ar	0.8		
Kr	0.5		
Xe	0.4		

(Indicated factors are average values.)

**Installation**

**Vacuum Connection**

**STOP DANGER**

Caution: overpressure in the vacuum system >1 bar  
Injury caused by released parts and harm caused by escaping process gases can result if clamps are opened while the vacuum system is pressurized.  
Do not open any clamps while the vacuum system is pressurized. Use the type clamps which are suited to overpressure.

**STOP DANGER**

Caution: overpressure in the vacuum system >2 bar  
KF flange connections with elastomer seals (e.g. O-rings) cannot withstand such pressures. Process media can thus leak and possibly damage your health.  
Use O-rings provided with an outer centering ring.

**STOP DANGER**

Caution: protective ground  
Incorrectly grounded products can be extremely hazardous in the event of a fault.  
The gauge must be electrically connected to the grounded vacuum chamber. This connection must conform to the requirements of a protective connection according to EN 61010:

- CF connection fulfill this requirement
- For gauges with a KF flange, use a conductive metallic clamping ring

**Caution**

Caution: vacuum component  
Dirt and damages impair the function of the vacuum component.  
When handling vacuum components, take appropriate measures to ensure cleanliness and prevent damages.

**Caution**

Caution: dirt sensitive area  
Touching the product or parts thereof with bare hands increases the desorption rate.  
Always wear clean, lint-free gloves and use clean tools when working in this area.

The gauge may be mounted in any orientation. To keep condensates and particles from getting into the measuring chamber, preferably choose a horizontal to upright position.  
The gauge is supplied with a built-in grid. For potentially contaminating applications and to protect the electrodes against light and fast particles, installation of the optional baffle is recommended (→ [1]).

<sup>1)</sup> INFICON gauge controllers fulfill these requirements.  
<sup>2)</sup> Measured at the sensor cable connector (consider the voltage drop on the sensor cable).

(Installation, continued)

Remove the protective lid and install the product to the vacuum system.

 INFICON recommends to install the gauge without applying vacuum grease.

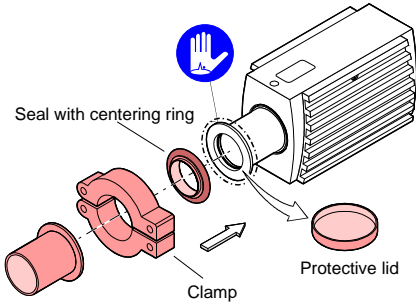

 Keep the protective lid.

## Electrical Connection (BCG450)

 The following information on the electrical connection as well as the wiring diagram applies to BCG450 only (→ [1] and [2] for details on the electrical connection and additional functions of BCG450-SD and -SP).

Make sure the vacuum connection is properly made (→ "Vacuum Connection").

**1** If no connection cable is available, make one according to the following diagram.

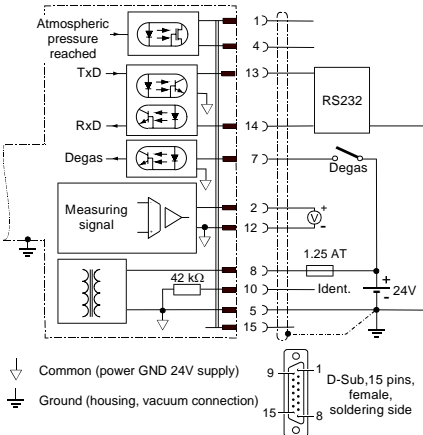

↓ Common (power GND 24V supply)  
 ⚡ Ground (housing, vacuum connection)

### Electrical connection

Pin 1	Relay "Atmosphere reached", n. o. contact	1)
Pin 2	Measuring signal output	0 ... +10.13 V
Pin 4	Relay "Atmosphere reached", com contact	1)
Pin 5	Supply common	0 V
Pin 7	Degas on, active high	0 V/+24 V
Pin 8	Supply	+24 V
Pin 10	Gauge identification	
Pin 12	Measuring signal common	
Pin 13	RS232, Tx	
Pin 14	RS232, Rx	
Pin 15	Do not connect	

Pins , 3, 6, 9 and 11 are not connected internally.

1) Detailed information on the atmosphere switching function and the "Atmosphere reached" relay → [1].

**2** Connect the sensor cable to the gauge.

**3** Secure the cable connector with the lock screws.

**4** Connect the sensor cable to the controller.

## Operation

When the supply voltage is applied, the measuring signal is available between pins 2 (+) and 12 (-) (Relationship Measuring Signal – Pressure → "Technical Data" and [1]).

BCG450-SD and -SP can also be operated via the corresponding fieldbus interface (DeviceNet or Profibus, → [1] and [2] for further details and functions).

Allow for a stabilizing time of ≈10 minutes. Once the gauge has been switched on, permanently leave it on irrespective of the pressure.

## Gas Type Dependence

Pressure range	Measuring principle	Gas type dependence
10 ... 1500 mbar	capacitance diaphragm sensor	independent of gas type, no correction required
1 ... 10 mbar	capacitance diaphragm sensor and Pirani sensor	crossover range
$2 \times 10^{-2}$ ... 1 mbar	Pirani sensor	1)
$5 \times 10^{-3}$ ... $2 \times 10^{-2}$ mbar	Pirani sensor and hot cathode ionisation sensor (BA)	crossover range
$5 \times 10^{-10}$ ... $5 \times 10^{-3}$ mbar	hot cathode ionisation sensor (BA)	1)

1) → Table "Technical Data, Calibration factors"

## Adjusting the Gauge

The gauge is adjusted automatically (adjustment of the atmosphere switching function (atmosphere sensor) → [1]).

## Display

(BCG450 with part numbers 353-552 and 353-553)



Pressure reading

Pressure unit

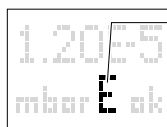

Function display

(none) Pirani operation  
 E Emission 25 μA  
 E . Emission 5 mA  
 I Degas

### Error display:



No error (green background illumination)



Pirani sensor error (red background illumination)



BA sensor error (red background illumination)

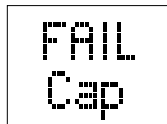

Diaphragm sensor error (red background illumination)



EEPROM error (red background illumination)

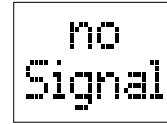

Internal data connection failure (red background illumination)

## Deinstallation

 **DANGER**



Caution: contaminated parts

Contaminated parts can be detrimental to health and environment.

Before beginning to work, find out whether any parts are contaminated. Adhere to the relevant regulations and take the necessary precautions when handling contaminated parts.

 **Caution**



Caution: vacuum component

Dirt and damages impair the function of the vacuum component.

When handling vacuum components, take appropriate measures to ensure cleanliness and prevent damages.

 **Caution**



Caution: dirt sensitive area

Touching the product or parts thereof with bare hands increases the desorption rate.

Always wear clean, lint-free gloves and use clean tools when working in this area.

**1** Vent the vacuum system.

**2** Turn the gauge off, switch off power supply.

**3** Unfasten the lock screws and unplug the sensor cable. (If you are using BCG450-SD or -SP, unfasten and unplug the interface cable too (→ [1] and [2]).

**4** Remove the gauge from the vacuum system and replace the protective lid.

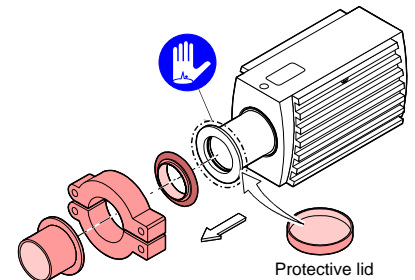

## Maintenance, Troubleshooting

In case of severe contamination or a malfunction, the sensor can be replaced (→ [1]).

Adjustment of the atmosphere sensor is described in detail in [1].



Gauge failures due to contamination are not covered by the warranty.

## Returning the Product

**WARNING**

Caution: forwarding contaminated products

Contaminated products (e.g. radioactive, toxic, caustic or microbiological hazard) can be detrimental to health and environment.

Products returned to INFICON should preferably be free of harmful substances. Adhere to the forwarding regulations of all involved countries and forwarding companies and enclose a duly completed declaration of contamination

Products that are not clearly declared as "free of harmful substances" are decontaminated at the expense of the customer.

Products not accompanied by a duly completed declaration of contamination are returned to the sender at his own expense.

## Disposal

**DANGER**

Caution: contaminated parts

Contaminated parts can be detrimental to health and environment.

Before beginning to work, find out whether any parts are contaminated. Adhere to the relevant regulations and take the necessary precautions when handling contaminated parts.

**WARNING**

Caution: substances detrimental to the environment

Products or parts thereof (mechanical and electric components, operating fluids etc.) can be detrimental to the environment.

Dispose of such substances in accordance with the relevant local regulations.

## Separating the components

After disassembling the product, separate its components according to the following criteria:

- Contaminated components  
Contaminated components (radioactive, toxic, caustic, or biological hazard etc.) must be decontaminated in accordance with the relevant national regulations, separated according to their materials, and recycled.
- Other components  
Such components must be separated according to their materials and recycled.

## Further Information

[1] [www.inficon.com](http://www.inficon.com)  
Operating Manual  
TripleGauge™ BCG450, BCG450-SD, BCG450-SP  
tima40e1  
INFICON AG, LI-9496 Balzers, Liechtenstein

[2] [www.inficon.com](http://www.inficon.com)  
Instruction Sheet  
TripleGauge™ BCG450-SD, BCG450-SP  
tima41e1  
INFICON AG, LI-9496 Balzers, Liechtenstein

## Declaration of Contamination

The service, repair, and/or disposal of vacuum equipment and components will only be carried out if a correctly completed declaration has been submitted. Non-completion will result in delay. This declaration may only be completed (in block letters) and signed by authorized and qualified staff.

- Description of product**  
Type \_\_\_\_\_  
Part number \_\_\_\_\_  
Serial number \_\_\_\_\_
- Reason for return**  
\_\_\_\_\_
- Operating fluid(s) used**  
(Must be drained before shipping.)  
\_\_\_\_\_
- Used in copper process**  
no  yes  **Seal product in plastic bag and mark it with a corresponding label.**
- Process related contamination of product:**  

toxic	no <input type="checkbox"/> 1)	yes <input type="checkbox"/>	
corrosive	no <input type="checkbox"/> 1)	yes <input type="checkbox"/>	
biological hazard	no <input type="checkbox"/>	yes <input type="checkbox"/> 2)	
explosive	no <input type="checkbox"/>	yes <input type="checkbox"/> 2)	
radioactive	no <input type="checkbox"/>	yes <input type="checkbox"/> 2)	
other harmful substances	no <input type="checkbox"/> 1)	yes <input type="checkbox"/>	

1) or not containing any amount of hazardous residues that exceed the permissible exposure limits

2) Products thus contaminated will not be accepted without written evidence of decontamination.

The product is free of any substances which are damaging to health. yes
- Harmful substances, gases and/or by-products**  
Please list all substances, gases, and by-products which the product may have come into contact with:  

Trade/product name manufacturer	Chemical name (or symbol)

Precautions associated with substance	Action if human contact
- Legally binding declaration:**  
We hereby declare that the information on this form is complete and accurate and that we will assume any further costs that may arise. The contaminated product will be dispatched in accordance with the applicable regulations.  
 Organization/company \_\_\_\_\_  
 Address \_\_\_\_\_  
 Post code, place \_\_\_\_\_  
 Phone \_\_\_\_\_ Fax \_\_\_\_\_  
 Email \_\_\_\_\_  
 Name \_\_\_\_\_  
 Company stamp \_\_\_\_\_

This form can be downloaded from our website.  
Copies: Original for addressee  
1 copy for accompanying documents  
1 copy for file of sender

## Declaration of Conformity



We, INFICON, hereby declare that the equipment mentioned below complies with the provisions of the Directive relating to electrical equipment designed for use within certain voltage limits 73/23/EEC and the Directive relating to electromagnetic compatibility 89/336/EEC.

## TripleGauge™

Bayard-Alpert Pirani Capacitance Diaphragm Gauge

BCG450  
BCG450-SD  
BCG450-SP

## Part numbers

353-550  
353-551  
353-552  
353-553  
353-554  
353-556  
353-557  
353-558

## Standards

Harmonized and international/national standards and specifications:

- EN 61010-1 (Safety requirements for electrical equipment for measurement, control and laboratory use)
- EN 61000-6-2 (Electromagnetic compatibility generic immunity standard)
- EN 61000-6-3 (Electromagnetic compatibility generic emission standard)
- EN 50325 (DeviceNet standard)
- EN 50170 (Profibus standard)

## Signatures

INFICON AG, Balzers

09 March 2004

Michael Schöch  
Product Marketing Manager

09 March 2004

Dr. Georg Sele  
Technical Support Manager  
Quality Representative



LI-9496 Balzers  
Liechtenstein  
Tel +423 / 388 3111  
Fax +423 / 388 3700  
reachus@inficon.com  
www.inficon.com