

Bayard-Alpert Pirani Gauge

Dual Filament Bayard-Alpert Pirani Gauge

BPG402-S
BPG402-SD
BPG402-SP

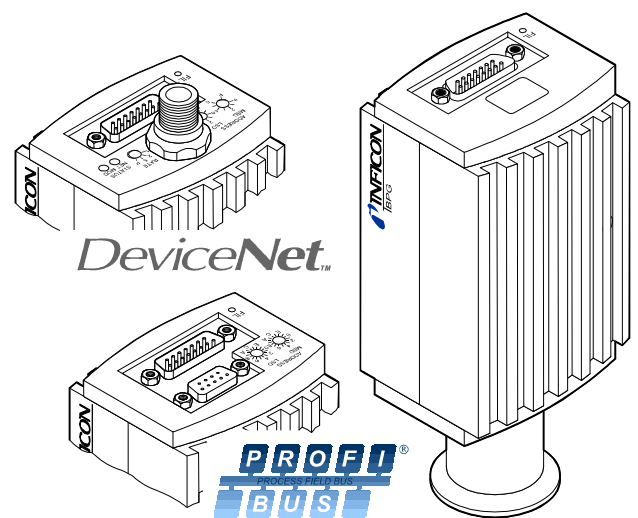

Product Identification

In all communications with INFICON, please specify the information on the product nameplate. For convenient reference copy that information into the space provided below.

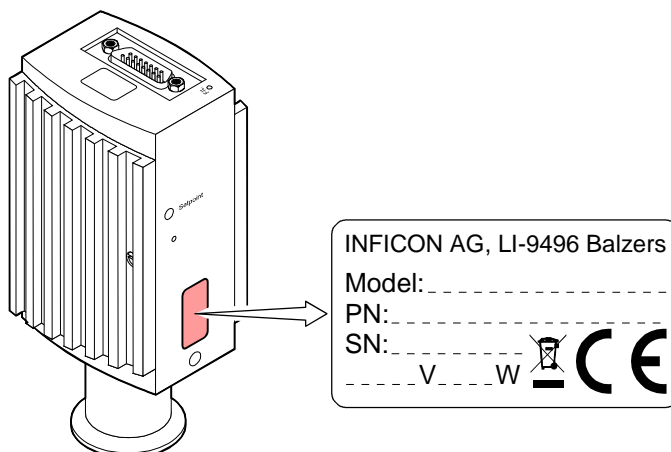

Validity

This document applies to products with the following part numbers:

BPG402-S (without display, one switching function)

353-570 (vacuum connection DN 25 ISO-KF)

353-571 (vacuum connection DN 40 CF-R)

BPG402-S (with display, one switching function)

353-572 (vacuum connection DN 25 ISO-KF)

353-573 (vacuum connection DN 40 CF-R)

BPG402-SD (with DeviceNet interface and two switching functions)

353-576 (vacuum connection DN 25 ISO-KF)

353-577 (vacuum connection DN 40 CF-R)

BPG402-SP (with Profibus interface and two switching functions)

353-574 (vacuum connection DN 25 ISO-KF)

353-575 (vacuum connection DN 40 CF-R)

The part number (PN) can be taken from the product nameplate.

If not indicated otherwise in the legends, the illustrations in this document correspond to gauge with part number 353-572. They apply to the other gauges by analogy.

We reserve the right to make technical changes without prior notice.

All dimensions in mm.

Intended Use

The BPG402-Sx gauges have been designed for vacuum measurement of non-flammable gases and gas mixtures in a pressure range of 5×10^{-10} ... 1000 mbar.

The gauges can be operated in connection with the INFICON Vacuum Gauge Controller VGC40x or with other control devices.

Functional Principle

Over the whole measuring range, the gauge has a continuous characteristic curve and its measuring signal is output as logarithm of the pressure.



The gauge functions with a Bayard-Alpert hot cathode ionization measurement system (for $p < 2.0 \times 10^{-2}$ mbar) and a Pirani measurement system (for $p > 5.5 \times 10^{-3}$ mbar). In the overlapping pressure range of $2.0 \times 10^{-2} \dots 5.5 \times 10^{-3}$ mbar, a mixed signal of the two measurement systems is output. The hot cathode is switched on by the Pirani measurement system only below the switching threshold of 2.4×10^{-2} mbar (to prevent filament burn-out). It is switched off when the pressure exceeds 3.2×10^{-2} mbar.

BPG402-Sx sensors are equipped with two hot cathodes. The identical filaments are monitored by the gauge electronics. In case of a filament failure, the gauge will switch over to the second (undamaged) filament and continue to operate. The filament status is displayed on the gauge or can be read via the interfaces (RS232C, DeviceNet or Profibus).

Contents

Product Identification	2
Validity	2
Intended Use	2
Functional Principle	3
1 Safety	6
1.1 Symbols Used	6
1.2 Personnel Qualifications	6
1.3 General Safety Instructions	7
1.4 Liability and Warranty	7
2 Technical Data	8
3 Installation	13
3.1 Vacuum Connection	13
3.1.1 Removing and Installing the Electronics Unit	14
3.1.2 Using the Optional Baffle	15
3.2 Electrical Connection	17
3.2.1 Use With INFICON VGC40x Vacuum Gauge Controller	17
3.2.2 Use With Other Controllers	17
3.2.2.1 Making an Individual Sensor Cable	18
3.2.2.2 Making a DeviceNet Interface Cable (BPG402-SD)	21
3.2.2.3 Making a Profibus Interface Cable (BPG402-SP)	22
3.2.3 Using the Optional Power Supply (With RS232C Line)	23
4 Operation	25
4.1 Measuring Principle, Measuring Behavior	25
4.2 Operational Principle of the Gauge	27
4.3 Putting the Gauge Into Operation	27
4.4 Degas	27
4.5 Filament Status	28
4.5.1 Filament Status Indicator	28
4.5.2 Filament Status Relay (Only BPG402-S)	28
4.5.3 Filament Status via Interface	28
4.6 Filament Control Mode	28
4.7 Emission Control Mode	29
4.8 Display (BPG402-S)	29
4.9 RS232C Interface	30
4.9.1 Description of the Functions	30
4.9.1.1 Output String (Transmit)	31
4.9.1.2 Input String (Receive)	33
4.10 DeviceNet Interface (BPG402-SD)	34
4.10.1 Description of the Functions	34
4.10.2 Operating Parameters	34
4.10.2.1 Operating Software	34
4.10.2.2 Node Address Setting	34
4.10.2.3 Data Rate Setting	35
4.10.3 Status Indicators	35
4.11 Profibus Interface (BPG402-SP)	36
4.11.1 Description of the Functions	36
4.11.2 Operating Parameters	36
4.11.2.1 Operating Software	36
4.11.2.2 Node Address Setting	36
4.12 Switching Functions	37
4.12.1 Setting the Switching Functions	38
5 Deinstallation	39

6 Maintenance, Repair	41
6.1 Cleaning the Gauge	41
6.2 Adjusting the Gauge	41
6.2.1 Adjustment at Atmospheric Pressure	41
6.2.2 Zero Point Adjustment	42
6.3 What to Do in Case of Problems	42
6.4 Replacing the Sensor	44
7 Options	45
8 Spare Parts	45
9 Storage	45
10 Returning the Product	46
11 Disposal	46
Appendix	47
A: Relationship Output Signal – Pressure	47
B: Gas Type Dependence	48
C: Literature	50
Declaration of Contamination	51

For cross-references within this document, the symbol (→  XY) is used, for cross-references to further documents and data sources, the symbol (→  [Z]).

1 Safety

1.1 Symbols Used

DANGER

Information on preventing any kind of physical injury.

WARNING

Information on preventing extensive equipment and environmental damage.

Caution

Information on correct handling or use. Disregard can lead to malfunctions or minor equipment damage.



Notice



Hint, recommendation



The result is O.K.



The result is not as expected



Optical inspection



Waiting time, reaction time

1.2 Personnel Qualifications

Skilled personnel

All work described in this document may only be carried out by persons who have suitable technical training and the necessary experience or who have been instructed by the end-user of the product.

1.3 General Safety Instructions

- Adhere to the applicable regulations and take the necessary precautions for the process media used.
Consider possible reactions between the materials (→ 11) and the process media.
Consider possible reactions of the process media (e.g. explosion) due to the heat generated by the product.
- Adhere to the applicable regulations and take the necessary precautions for all work you are going to do and consider the safety instructions in this document.
- Before beginning to work, find out whether any vacuum components are contaminated. Adhere to the relevant regulations and take the necessary precautions when handling contaminated parts.

Communicate the safety instructions to all other users.

1.4 Liability and Warranty

INFICON assumes no liability and the warranty becomes null and void if the end-user or third parties

- disregard the information in this document
- use the product in a non-conforming manner
- make any kind of interventions (modifications, alterations etc.) on the product
- use the product with accessories not listed in the corresponding product documentation.

The end-user assumes the responsibility in conjunction with the process media used.

Gauge failures due to contamination, as well as expendable parts (filament), are not covered by the warranty.

2 Technical Data

Measurement	Measurement range (air, O ₂ , CO, N ₂)	5×10 ⁻¹⁰ ... 1000 mbar, continuous
	Accuracy (after 10 min. stabilization)	15% of reading in the range of 1×10 ⁻⁸ ... 10 ⁻² mbar
	Repeatability (after 10 min. stabilization)	5% of reading in the range of 1×10 ⁻⁸ ... 10 ⁻² mbar
	Gas type dependence	→ Appendix B
Emission	Switching on threshold	2.4×10 ⁻² mbar
	Switching off threshold	3.2×10 ⁻² mbar
	Emission current	
	p ≤ 7.2×10 ⁻⁶ mbar	5 mA
	7.2×10 ⁻⁶ mbar < p < 3.2×10 ⁻² mbar	25 μA
	Emission current switching	
	25 μA ⇒ 5 mA	7.2×10 ⁻⁶ mbar
	5 mA ⇒ 25 μA	3.0×10 ⁻⁵ mbar
	Filaments	
	Number	2
	Means of selection	Controlled by gauge (default) or via interfaces (→ ¶ 33, ¶ [1] and ¶ [9])
	Settling time of measurement signal after filament change	<4 s
	Filament status	LED, relay contact (→ ¶ 28)
Emission control mode		
Automatic	Emission ON/OFF automatically	
Manual	Emission ON/OFF by user via interfaces (→ ¶ 29)	
Degas	Current (p < 7.2×10 ⁻⁶ mbar)	≈20 mA
	Control input signal	0 V/+24 VDC, active high (→ ¶ 19, 20) (control via RS232C → ¶ 30)
	Duration	<3 min., followed by automatic stop
	In degas mode, the BPG402-Sx gauges keep supplying pressure readings, the tolerances of which can be higher than during normal operation. Degas acts only upon the active filament.	
Output signal	Output signal (measuring signal)	0 ... +10 VDC
	Measuring range	+0.774 ... +10 V (5×10 ⁻¹⁰ ... 1000 mbar)
	Relationship voltage-pressure	logarithmic, 0.75 V/decade (→ Appendix A)
	Error signal (→ ¶ 42)	
	EEPROM error	≈+0.1 VDC
	Hot cathode error	≈+0.3 VDC
Pirani error	≈+0.5 VDC	
Minimum load impedance	10 kΩ	
Gauge identification	BPG402-Sx	42 kΩ resistor between Pin 10 and Pin 5 (sensor cable)

Switching functions

BPG402-S	1 ("SETPOINT")
BPG402-SD, -SP	2 ("SETPOINT A, B")
Adjustment range	1×10 ⁻⁹ mbar ... 100 mbar Setpoints adjustable via potentiometers, one floating, normally open relay contact per setpoint (→ 19 , 20 , 37). (Adjusting the setpoints via field bus → corresponding bus section)
Hysteresis	10% of the threshold value
Relaiskontaktbelastung	≤60 VDC, ≤0.5 ADC

RS232C interface

Data rate	9600 Baud
Data format	binary 8 data bits one stop bit no parity bit no handshake
Connections (sensor cable connector)	
TxD (Transmit Data)	Pin 13
RxD (Receive Data)	Pin 14
GND	Pin 5
Function and communication protocol of the RS232C interface → 30	



DeviceNet interface (BPG402-SD)

Fieldbus name	DeviceNet
Standard applied	→ 6
Communication protocol, data format	→ 1 , 4
Interface, physical	CAN bus
Data rate (adjustable via "RATE" switch)	125 kBaud 250 kBaud 500 kBaud (default) "P" (125 kBaud, 250 kBaud, 500 kBaud programmable via DeviceNet) (→ 1)
Node address (MAC ID) (Adjustable via "ADDRESS", "MSD", "LSD" switches)	0 ... 63 _{dec} (default = 63 _{dec}) "P" (0 ... 63 programmable via DeviceNet, → 1)
DeviceNet connector	Micro-Style, 5 pins, male
Cable	shielded, special DeviceNet cable, 5 conductors (→ 21 and 4)
Cable length, system wiring	according to DeviceNet specifications (→ 6 , 4)

Electrical connection



For reasons of compatibility, the expression "sensor cable" is used for all BPG402 versions in this document, although the pressure reading of the gauges with fieldbus interface (BPG402-SD and BPG402-SP) is normally transmitted via the corresponding bus.

Electrical connection	D-Sub, 15 pins, male
BPG402-S	→  19
BPG402-SD, -SP	→  20
Sensor cable	shielded, number of conductors depending on the functions used, max. 15 conductors plus shielding
Cable length (supply voltage 24 VDC ¹⁾)	
Analog and fieldbus operation	≤35 m, 0.25 mm ² /conductor ≤50 m, 0.34 mm ² /conductor ≤100 m, 1.0 mm ² /conductor
For operation with RS232C interface	≤30 m

Materials used

Materials exposed to vacuum	
Housing, supports, screens	stainless steel
Feedthroughs	NiFe, nickel plated
Insulator	glass
Cathode	iridium, yttrium oxide (Y ₂ O ₃)
Cathode holder	molybdenum, platinum
Pirani element	tungsten, copper
Internal volume	
DN 25 ISO-KF	≈24 cm ³
DN 40 CF-R	≈34 cm ³
Pressure max.	2 bar (absolute)

Ambiance

Admissible temperatures	
Storage	-20 ... 170 °C
Operation	0 ... 150 °C
Bakeout	+80 °C (flange temperature, electronics unit removed, horizontally mounted)
Relative humidity	
Year's mean	≤65 (no condensation)
During 60 days	85% (no condensation)
Use	indoors only altitude up to 2000 m NN
Mounting orientation	any
Type of protection	IP 30

Dimensions [mm]

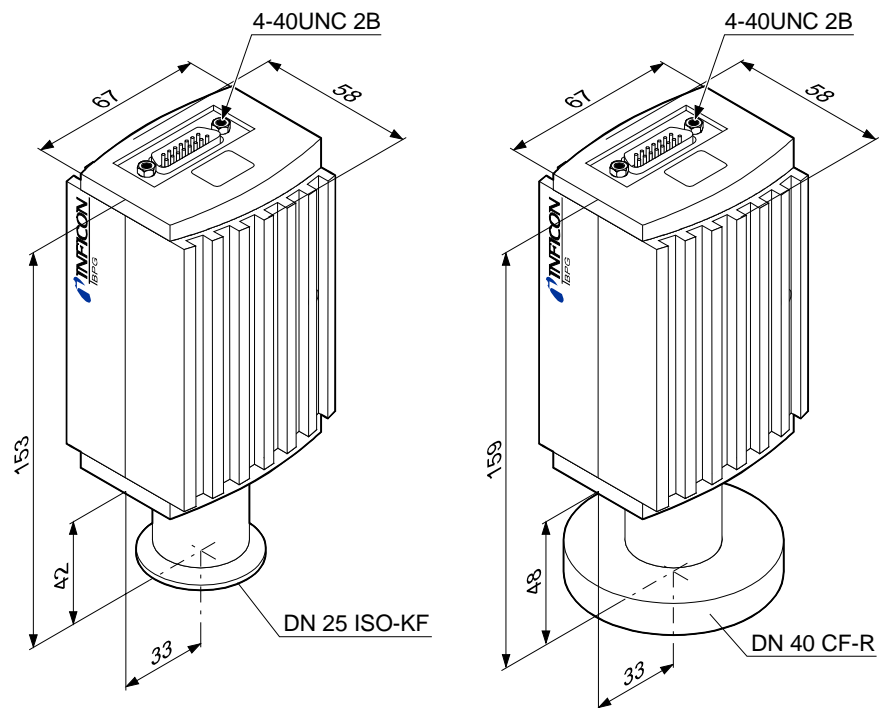

Gauges with DeviceNet connector are 14 mm longer.

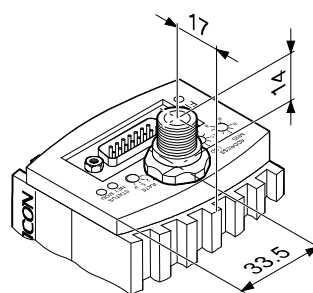

Weight

353-570, 353-572	≈450 g
353-571, 353-573	≈710 g
353-574, 353-576	≈490 g
353-575, 353-577	≈750 g

3 Installation

3.1 Vacuum Connection



DANGER

DANGER: overpressure in the vacuum system >1 bar
Injury caused by released parts and harm caused by escaping process gases can result if clamps are opened while the vacuum system is pressurized.

Do not open any clamps while the vacuum system is pressurized. Use the type of clamps which are suited to overpressure.



DANGER

The gauge must be electrically connected to the grounded vacuum chamber. This connection must conform to the requirements of a protective connection according to EN 61010:

- CF connections fulfill this requirement
- For gauges with a KF vacuum connection, use a conductive metallic clamping ring.



Caution



Caution: vacuum component
Dirt and damages impair the function of the vacuum component.
When handling vacuum components, take appropriate measures to ensure cleanliness and prevent damages.



Caution



Caution: dirt sensitive area
Touching the product or parts thereof with bare hands increases the desorption rate.
Always wear clean, lint-free gloves and use clean tools when working in this area.



The gauge may be mounted in any orientation. To keep condensates and particles from getting into the measuring chamber, preferably choose a horizontal to upright position. See dimensional drawing for space requirements (→ [12](#)).

The gauge is supplied with a built-in grid. For potentially contaminating applications and to protect the electrodes against light and fast charged particles, installation (→ [15](#)) of the optional baffle is recommended (→ [45](#)).



When installing the gauge, make sure that the area around the connector is accessible for the tools required for adjustment while the gauge is mounted (→ [38](#), [41](#)).

When installing the gauge, allow for installing/deinstalling the connectors and accommodation of cable loops.

If you are using a gauge with display, make sure easy reading of the display is possible.



Vacuum connection free of grease.

Procedure

Remove the protective lid and install the gauge to the vacuum system.

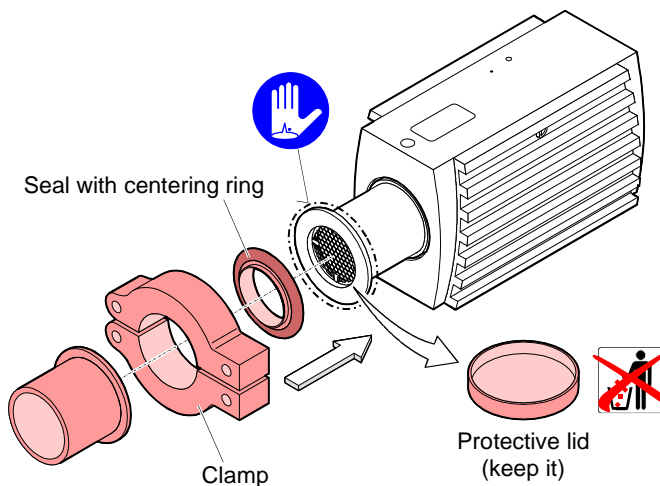

3.1.1 Removing and Installing the Electronics Unit

Required tools / material

- Allen wrench, AF 2.5

Removing the electronics unit

- 1 Unscrew the hexagon socket set screw (1) on the side of the electronics unit (2).

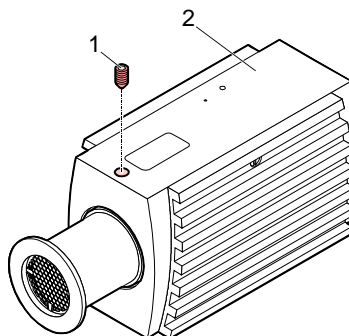

- 2 Remove the electronics unit **without twisting it**.

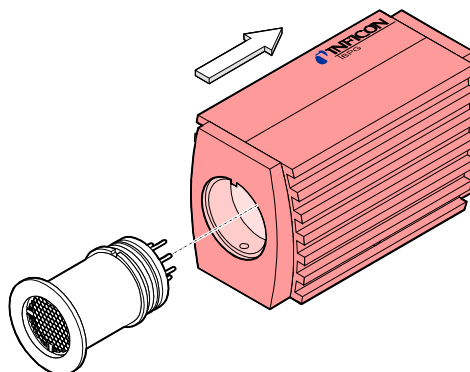

Installing the electronics unit

- 3 Place the electronics unit (2) on the sensor (3) (be careful to correctly align the pins and notch (4)).

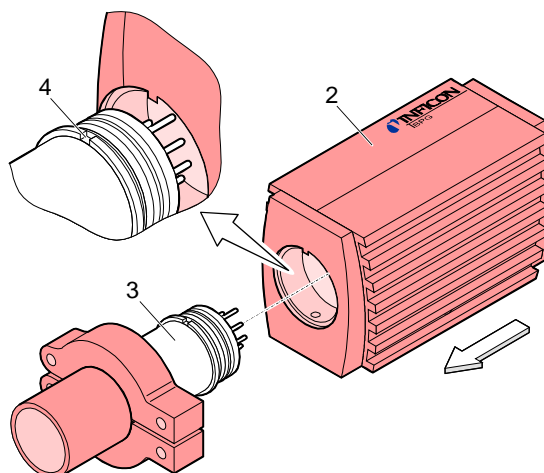

- 4 Slide the electronics unit in to the mechanical stop and lock it with the hexagon socket set screw.

3.1.2 Using the Optional Baffle

In severely contaminating processes and to protect measurement electrodes optically against light and fast charged particles, replacement of the built-in grid by the optional baffle (→ 45) is recommended.

Precondition

Gauge deinstalled ("Deinstallation" → 39).

Required tools / material

- Baffle (→ 45)
- Pointed tweezers
- Pin (e.g. pencil)
- Screwdriver No 1

Installation

- 1 Carefully remove the grid with tweezers.

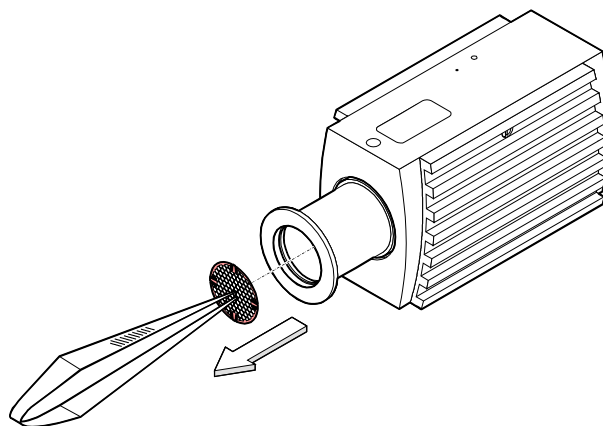

- 2** Carefully place the baffle onto the sensor opening.

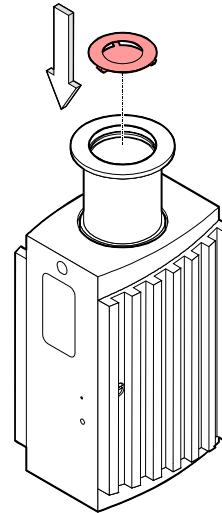

- 3** Using a pin, press the baffle down in the center until it catches.

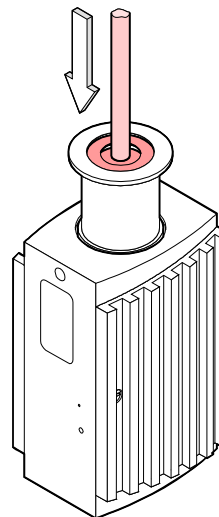

Deinstallation

Carefully remove the baffle with the screwdriver.

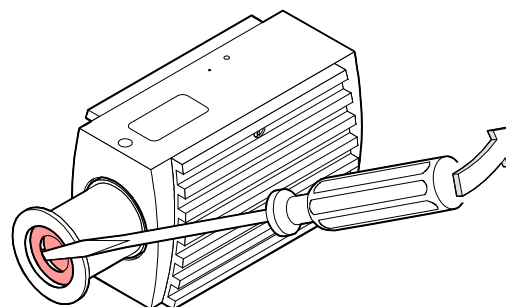

3.2 Electrical Connection

3.2.1 Use With INFICON VGC40x Vacuum Gauge Controller

If the gauge is used with an INFICON VGC40x controller, a corresponding sensor cable is required (→ [3]). The sensor cable permits supplying the gauge with power, transmitting measurement values and gauge statuses, and making parameter settings.

Caution

Caution: data transmission errors
 If the gauge is operated with the INFICON VGC40x Vacuum Gauge Controller (RS232C) and a fieldbus interface at the same time, data transmission errors may occur.
 The gauge must not be operated with an INFICON VGC40x controller and DeviceNet or Profibus at the same time.

Required material

- Sensor cable (→ [3]), INFICON sales literature)

Procedure

- 1 Plug the sensor connector into the gauge and secure it with the locking screws.
- 2 Connect the other end of the sensor cable to the INFICON controller and secure it.

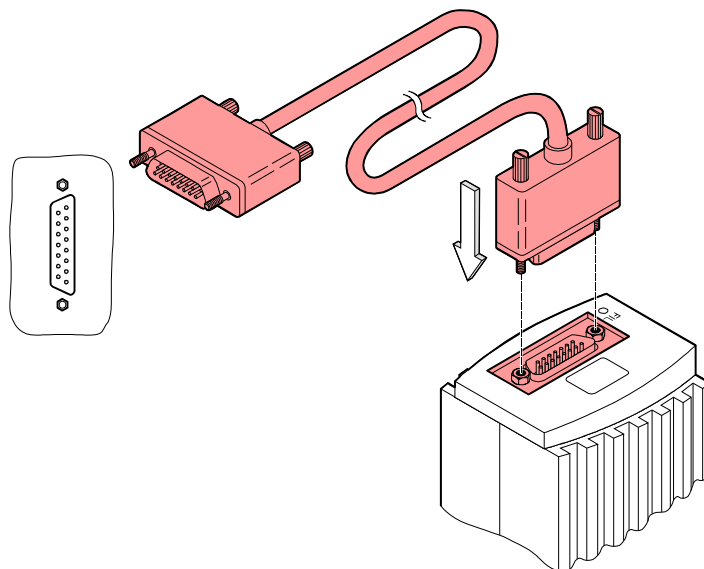

3.2.2 Use With Other Controllers

The gauge can also be operated with other controllers.

Especially the fieldbus versions BPG402-SD (DeviceNet) and BPG402-SP (Profibus) are usually operated as part of a network, controlled by a master or bus controller. In such cases, the control system has to be operated with the appropriate software and communication protocol (→ [1], [2]).

3.2.2.1 Making an Individual Sensor Cable



For reasons of compatibility, the expression "sensor cable" is used for all BPG402 versions in this document, although the pressure reading of the gauges with fieldbus interface (BPG402-SD or BPG402-SP) is normally transmitted via DeviceNet or Profibus.

The sensor cable is required for supplying all BPG402 types with power. It also permits access to the relay contacts of the switching functions (→ [19](#), [20](#)).

Cable type

The application and length of the sensor cable have to be considered when determining the number and cross sections of the conductors (→ [11](#)).

Procedure

- 1 Open the cable connector (D-Sub, 15 pins, female).
- 2 Prepare the cable and solder/crimp it to the connector as indicated in the diagram of the gauge used:

Sensor cable connection
BPG402-S

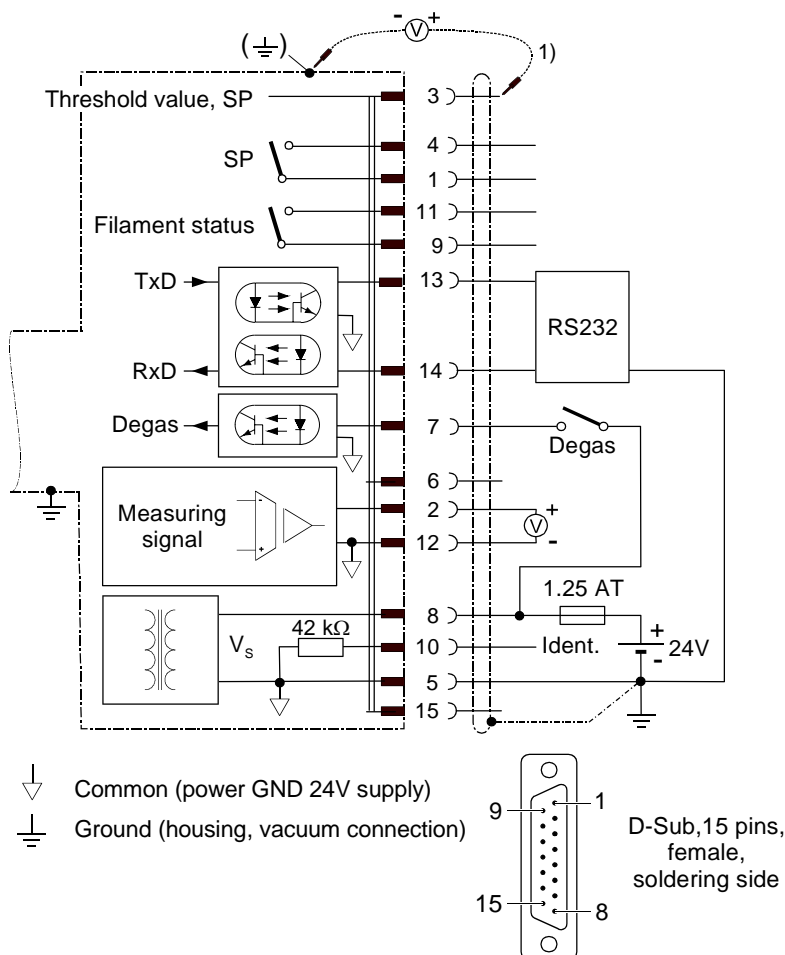

Electrical connection

Pin 1	Relay switching function, common contact	
Pin 2	Measuring signal output	0 ... +10 V
Pin 3	Threshold (setpoint) ¹⁾	0 ... +10 V
Pin 4	Relay switching function, n.o. contact	
Pin 5	Supply common	0 V
Pin 6	Not connected internally	
Pin 7	Degas (active high)	0 V/+24 V
Pin 8	Supply (V _s)	+24 V
Pin 9	Relay filament status, common contact ²⁾	
Pin 10	Gauge identification	
Pin 11	Relay filament status, n.o. contact ²⁾	
Pin 12	Measuring signal common	
Pin 13	RS232C, TxD	
Pin 14	RS232C, RxD	
Pin 15	Do not connect	

¹⁾ Do not connect pin 3 for normal operation of the gauge. This pin is reserved for adjustment of the setpoint potentiometers (→ 38).

²⁾ → table on 28.

Sensor cable connection
BPG402-SD, -SP

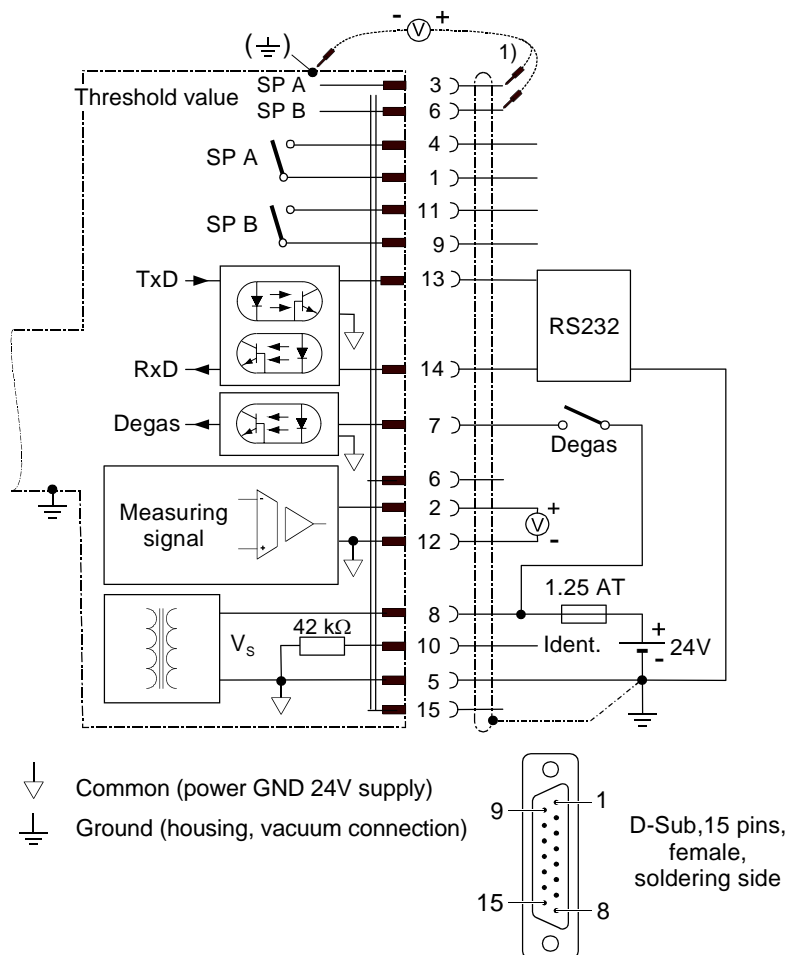

Electrical connection

Pin 1	Relay switching function A, common contact	
Pin 2	Measuring signal output	0 ... +10 V
Pin 3	Threshold (setpoint) A ¹⁾	0 ... +10 V
Pin 4	Relay switching function A, n.o. contact	
Pin 5	Supply common	0 V
Pin 6	Threshold (setpoint) B ¹⁾	0 ... +10 V
Pin 7	Degas (active high)	0 V/+24 V
Pin 8	Supply (V _s)	+24 V
Pin 9	Relay switching function B, common contact	
Pin 10	Gauge identification	
Pin 11	Relay switching function B, n.o. contact	
Pin 12	Measuring signal common	
Pin 13	RS232C, TxD	
Pin 14	RS232C, RxD	
Pin 15	Do not connect	

¹⁾ Do not connect pin 3 and pin 6 for normal operation of the gauge. These pins are reserved for adjustment of the setpoint potentiometers (→ 38).

WARNING

The supply common (Pin 5) and the shielding must be connected at the supply unit with protective ground.

Incorrect connection, incorrect polarity or inadmissible supply voltages can damage the gauge.



For cable lengths up to 5 m (0.34 mm² conductor cross-section) the output signal can be measured directly between the positive signal output (Pin 2) and supply common (Pin 5). At greater cable lengths, differential measurement between signal output (Pin 2) and signal common (Pin 12) is recommended.

- 3 Reassemble the cable connector.
- 4 On the other cable end, terminate the cable according to the requirements of the gauge controller you are using.
- 5 Plug the sensor connector into the gauge and secure it with the locking screws.

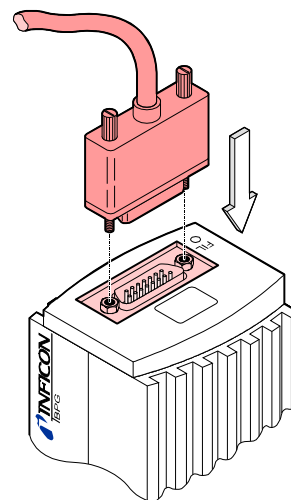

- 6 Connect the other end of the sensor cable to the connector of the instrument or gauge controller you are using.

3.2.2.2 Making a DeviceNet Interface Cable (BPG402-SD)

For operating BPG402-SD via DeviceNet, an interface cable conforming to the DeviceNet standard is required. If no such cable is available, make one according to the following indications.

Cable type

A shielded special 5 conductor cable conforming to the DeviceNet standard has to be used (→ [4], [6]).

Procedure

- 1 Make the DeviceNet cable according to the following indications.

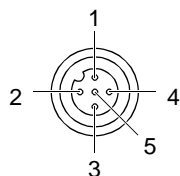

Micro-Style, 5 pins,
(DeviceNet)
female, soldering side

- | | | |
|-------|--|---------|
| Pin 1 | Drain | |
| Pin 2 | Supply (DeviceNet interface only) | +24 VDC |
| Pin 3 | Supply common (DeviceNet interface only) | GND |
| Pin 4 | CAN_H | |
| Pin 5 | CAN_L | |

- 2 Plug the DeviceNet (and sensor) cable connector into the gauge.

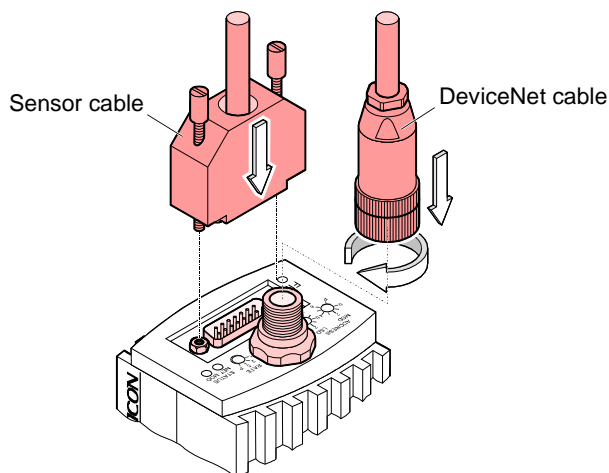

- 3 Lock the DeviceNet (and sensor) cable connector.

3.2.2.3 Making a Profibus Interface Cable (BPG402-SP)

For operating BPG402-SP via Profibus, an interface cable conforming to the Profibus standard is required.

If no such cable is available, make one according to the following indications.

Cable type

Only a cable that is suited to Profibus operation may be used (→ [5], [7]).

Procedure

- 1 Make the Profibus interface cable according to the following indications:

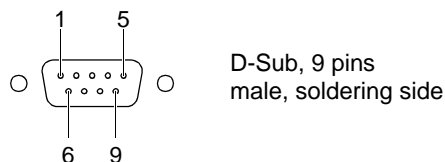

Pin 1 Do not connect

Pin 2 Do not connect

Pin 3 RxD/TxD-P

Pin 4 CNTR-P 1)

Pin 5 DGND 2)

Pin 6 VP 2)

Pin 7 Do not connect

Pin 8 RxD/TxD-N

Pin 9 Do not connect

1) Only to be connected if an *optical link* module is used.

2) Only required as line termination for devices at both ends of bus system (→ [5]).

- 2** Plug the Profibus (and sensor) cable connector into the gauge.

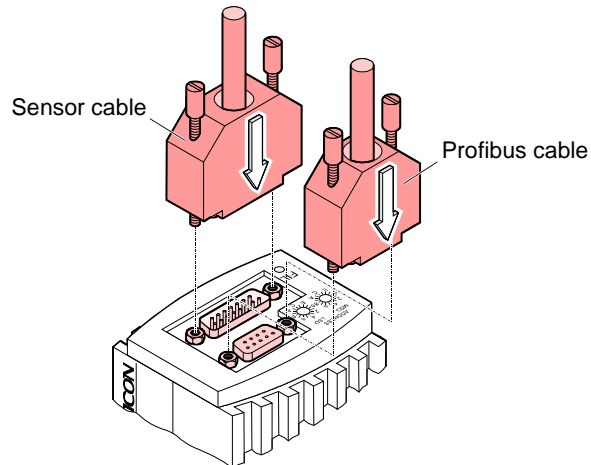

- 3** Lock the Profibus cable (and sensor cable) connector.

3.2.3 Using the Optional Power Supply (With RS232C Line)

Technical data

The optional 24 VDC power supply (→ [45](#)) allows RS232C operation of the BPG402-Sx gauge with any suitable instrument or control device.

The instrument or control device needs to be equipped with a software that supports the RS232C protocol of the gauge (→ [30](#)).

Mains connection

Mains voltage	90 ... 250 VAC, 50 ... 60 Hz
Mains cable	1.8 meter (Schuko DIN and U.S. connectors)

Output (operating voltage of gauge)

Voltage	21 ... 27 VDC, set to 24 VDC
Current	Max. 1.5 A

Gauge connection

Connector	D-Sub, 15 pins, female
24 VDC cable	5 m, black

Connection of the instrument or control device

RS232C connection	D-Sub, 9 pins, female
Cable	5 m, black, 3 conductors, shielded

Wiring diagram

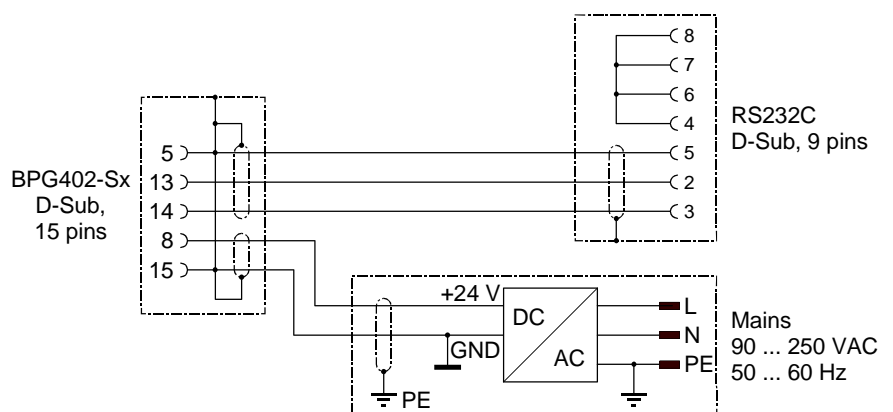

Connecting the power supply

- 1** Connect the power supply to the gauge and lock the connector with the screws.
- 2** Connect the RS232C line to the instrument or control device and lock the connector with the screws.

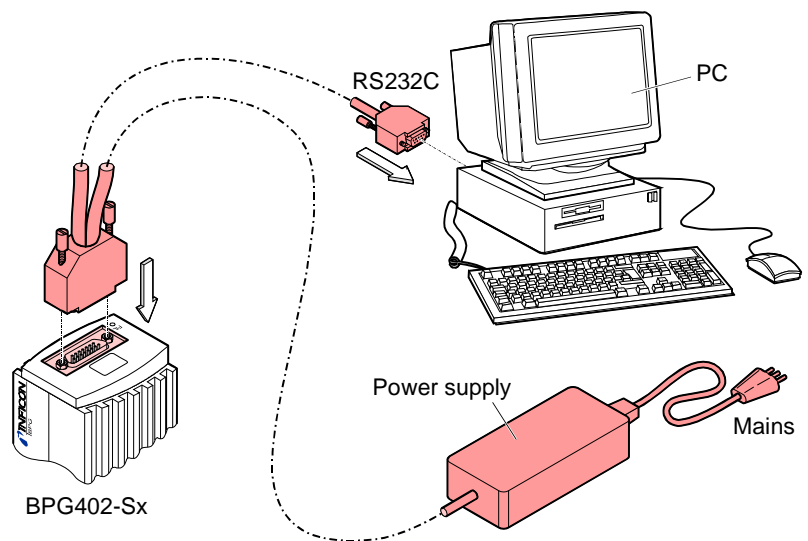

- 3** Connect the power supply to the mains.

4 Operation

4.1 Measuring Principle, Measuring Behavior

Bayard-Alpert

The BPG402-Sx vacuum gauges consist of two separate measuring systems (hot cathode Bayard-Alpert (BA) and Pirani).

The hot cathode measuring system uses an electrode system according to Bayard-Alpert which is designed for a low X-ray limit.

The measuring principle of this measuring system is based on gas ionization. Electrons emitted by the operating filament (F1 or F2, → below) ionize a number of molecules proportional to the pressure in the measuring chamber. The ion collector (IC) collects the produced ion current I^+ and feeds it to the electrometer amplifier of the measurement instrument. The ion current is dependent upon the emission current I_e , the gas type, and the gas pressure p according to the following relationship:

$$I^+ = I_e \times p \times C$$

Factor C represents the sensitivity of the gauge head. It is generally specified for N_2 .

The lower measurement limit is 5×10^{-10} mbar (gauge metal sealed).

To usefully cover the whole range of 5×10^{-10} mbar ... 10^{-2} mbar, a low emission current is used in the high pressure range (fine vacuum) and a high emission current is used in the low pressure range (high vacuum). The switching of the emission current takes place at decreasing pressure at approx. 7.2×10^{-6} mbar, at increasing pressure at approx. 3.0×10^{-5} mbar. At the switching threshold, the BPG402-Sx can temporarily (<2 s) deviate from the specified accuracy.

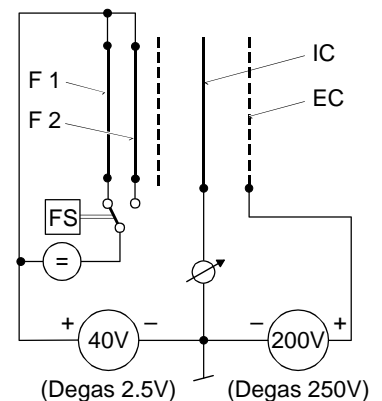
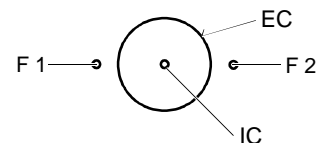

Diagram of the Bayard-Alpert measuring system

- F1/F2 hot cathodes (filaments)
- IC ion collector
- EC anode (electron collector)
- FS filament selector switch



Pirani

Within certain limits, the thermal conductivity of gases is pressure dependent. This physical phenomenon is used for pressure measurement in the thermal conductivity vacuum meter according to Pirani. A self-adjusting bridge is used as measuring circuit (→ schematic). A thin tungsten wire forms the sensor element. Wire resistance and thus temperature are kept constant through a suitable control circuit. The electric power supplied to the wire is a measure for the thermal conductance and thus the gas pressure. The basic principle of the self-adjusting bridge circuit is shown in the following schematic:

Schematic

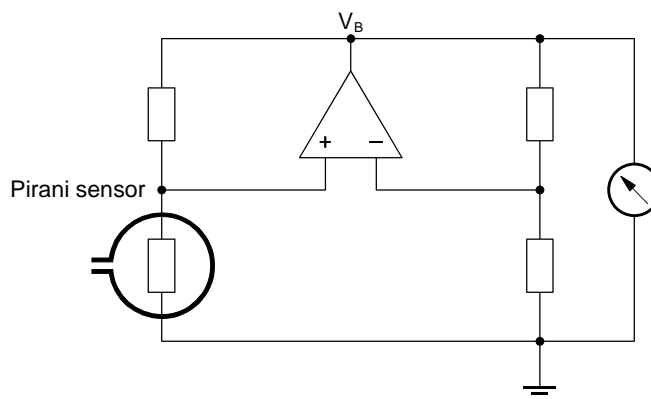

The bridge voltage V_B is a measure for the gas pressure and is further processed electronically (linearization, conversion).

Measuring range

The BPG402 -Sx gauges continuously cover the measuring range 5×10^{-10} mbar ... 1000 mbar.

- The Pirani constantly monitors the pressure.
- The hot cathode (controlled by the Pirani) is activated only at pressures $< 2.4 \times 10^{-2}$ mbar.

If the measured pressure is higher than the switching threshold, the hot cathode is switched off and the Pirani measurement value is output.

If the Pirani measurement drops below the switching threshold ($p = 2.4 \times 10^{-2}$ mbar), the hot cathode is switched on. After heating up, the measured value of the hot cathode is fed to the output. In the overlapping range of 5.5×10^{-3} ... 2.0×10^{-2} mbar, the output signal is generated from both measurements.

Pressure rising over the switching threshold ($p = 3.2 \times 10^{-2}$ mbar) causes the hot cathode to be switched off. The Pirani measurement value is output.

Gas type dependence

The output signal is gas type dependent. The characteristic curves are accurate for dry air, N_2 and O_2 . They can be mathematically converted for other gases (\rightarrow Appendix B).

Dual filament feature

BPG402-Sx sensors are equipped with two identical filaments. They are permanently monitored by the gauge electronics. In case of a filament breakage, the gauge will immediately react and switch over to the second (undamaged) filament. During the change over procedure, the last valid pressure value before filament failure will be output. As soon as the second filament is operating and the emission parameters have settled ($t < 4s$), the measuring circuit resumes operation. A "Hot Cathode Warning" is generated during this switch over cycle. The filament status indicator LED on the gauge will display the incident (blinking green, \rightarrow 28). The filament status can also be read via the RS232C or field bus interfaces (\rightarrow 30, [1] and [2]). Additionally, the BPG402-S offers a relay contact "Filament status" on the sensor cable connector (\rightarrow 19). In case of two broken filaments, a "Hot Cathode Error" is generated. Again, this status can be read via the interfaces (\rightarrow 30, [1] and [2]) and is also displayed by a red filament status indicator LED on the gauge (\rightarrow 28). In this case, the sensor has to be replaced (\rightarrow 44). At the beginning of every "Emission ON" cycle, the gauge alternates between filaments in order to age both filaments evenly. However, filament selection can be commanded via the interfaces (\rightarrow 28, 30, [1] and [2]).

INFICON recommends the replacement of the sensor as soon as the first filament failure has been detected. The replacement can be carried out during an appropriate off time such as the completion of a process or a planned maintenance brake.

4.2 Operational Principle of the Gauge

The analog measuring signals of the Bayard-Alpert and Pirani sensors are converted into a digital form by a micro-controller and subsequently converted to a value representing the measured total pressure. After further processing this value is available as analog measurement signal (0 ... +10 V) at the output (sensor cable connector Pin 2 and Pin 12). The maximum output signal is internally limited to +10 V (atmosphere). The measured value can be read as digital value through the RS232C interface (Pins 13, 14, 5) (→ ¶ 30). Gauges with a display show the value as pressure. The default setting of the displayed pressure unit is mbar. It can be modified via the RS232C interface (→ ¶ 30).

In addition to converting the output signal, the micro controller's functions include monitoring of the emission, filament status, calculation of the total pressure based on the measurements of the two sensors, and communication via RS232C interface.

4.3 Putting the Gauge Into Operation

When the operating voltage is supplied (→ Technical Data), the output signal is available between Pin 2 (+) and Pin 12 (-) of the sensor cable connector (Relationship Output Signal – Pressure → Appendix A).

Allow for a stabilizing time of approx. 10 min. Once the gauge has been switched on, permanently leave it on irrespective of the pressure.

Communication via the digital interfaces is described in separate sections.

4.4 Degas

Contamination



Gauge failures due to contamination, as well as expendable parts (filament), are not covered by the warranty.

Deposits on the electrode system of the Bayard-Alpert gauge can lead to unstable measurement readings.

The degas process allows in-situ cleaning of the electrode system by heating the electron collector grid to approx. 700 °C by electron bombardment.

Depending on the application, this function can be activated by the system control via one of the gauges digital interfaces. The gauge automatically terminates the degas process after 3 minutes, if it has not been stopped before.



The degas process should be run at pressures below 7.2×10^{-6} mbar (emission current 5 mA).

For a repeated degas process, the control signal first has to change from ON (+24 V) to OFF (0 V), to then start degas again with a new ON (+24 V) command. It is recommended that the degas signal be set to OFF again by the system control after 3 minutes of degassing, to achieve an unambiguous operating status.



A new degas cycle can only be started after a waiting time of 30 minutes.



Degas acts only upon the active filament.

4.5 Filament Status

4.5.1 Filament Status Indicator

The status of the dual filament hot cathode is indicated by a LED on top of the gauge.

Filament status indicator LED

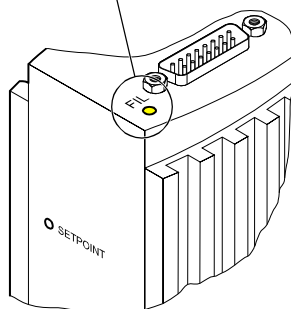

Filament status	Emission	Filament status indicator
–	off	dark
Both filaments O.K.	on	green
One filament broken	on	green, flashing
Both filaments broken	on	red



INFICON recommends the replacement of the sensor as soon as the first filament failure has been detected (replacing the sensor → 44).

4.5.2 Filament Status Relay (Only BPG402-S)

The BPG402-S features a "Filament status" relay contact available at the sensor cable connector:

Filament status	Relay contact (→ diagram 19)
Both filaments O.K.	closed
One filament broken	open
Both filaments broken	open

4.5.3 Filament Status via Interface

The filament status can be read via the serial interfaces:

Gauge	Interface	Detailed information
BPG402-Sx (all versions)	RS232C	→ 31
BPG402-SD	DeviceNet	→ [1]
BPG402-SP	Profibus	→ [2]

4.6 Filament Control Mode

In automatic mode (AUTO) (default) the gauge automatically alternates between filaments in order to age both filaments evenly. However, in manual mode (MAN), filament selection can be commanded via the interfaces.



The filament control mode can only be changed via the interfaces (→ 30, [1] and [2]).

4.7 Emission Control Mode

General

The emission control mode function defines the rules by which the emission of the gauge is switched on and off.

The manual mode feature has a positive effect on gauge live time, mainly in process situations where the process chamber has to be vented frequently.

Emission Control Mode	Description
<ul style="list-style-type: none"> Automatic (AUTO) 	By default, the automatic mode is active and the emission is switched on and off automatically by the gauge. However, the emission will only be switched on if the pressure falls below "Switching on pressure" (→ 8). If the pressure rises above the "Switching off pressure" (→ 8), the emission is switched off. However, the user can switch off the emission any time via the interfaces (→ below).
<ul style="list-style-type: none"> Manual (MAN) 	In manual mode, the emission can be switched on and off by the user. However, switching on the emission is only possible if the pressure is below "Switching on pressure" (→ 8). If the pressure rises above the "Switching off pressure" (→ 8) while the emission is on, the emission will be switched off by the gauge.



The emission control mode parameter is only accessible via the serial interfaces and described in the respective sections (→ 30, [1] and [2]).

4.8 Display (BPG402-S)

The gauges with part number
353-572 and
353-573

have a built-in two-line display with an LCD matrix of 32x16 pixels. The first line shows the pressure, the second line the pressure unit, the function and possible errors. The background illumination is usually green, in the event of an error, it changes to red. The pressure is displayed in mbar (default), Torr or Pa. The pressure unit can be changed via RS232C interface (→ 30).

Pressure Display

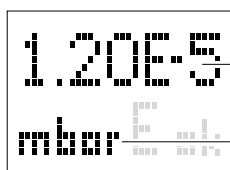

Pressure reading

Pressure unit

Function Display

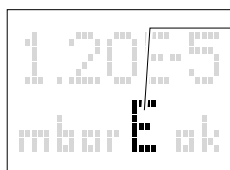

Function display
(none) Pirani operation
E Emission 25 µA
E . Emission 5 mA
D Degas

Error Display

	No error (green background illumination)
	Pirani sensor error (red background illumination)
	Bayard-Alpert sensor error (red background illumination)
	EEPROM error (red background illumination)
	Internal data communication failure (red background illumination)



What to do in case of problems → [42](#).

4.9 RS232C Interface

The built-in RS232C interface (all BPG402 versions) allows transmission of digital measurement data and instrument conditions as well as the setting of instrument parameters.

Caution

Caution: data transmission errors
If the gauge is operated with the RS232C interface and a fieldbus interface at the same time, data transmission errors may occur.
The gauge must not be operated with the RS232C interface and DeviceNet or Profibus at the same time.

4.9.1 Description of the Functions

Operational parameters

The interface works in duplex mode. A nine byte string is sent continuously without a request approx. every 6 ms.

Commands are transmitted to the gauge in a five byte input (receive) string.

- Data rate 9600 Baud (set value)
- Byte 8 data bits
 1 stop bit
- Handshake no
- Parity bit none

Electrical connections

- TxD Pin 13
- RxD Pin 14
- GND Pin 5
(Sensor cable connector)

4.9.1.1 Output String (Transmit)

The complete output string (frame) is nine bytes (byte 0 ... 8). The data string is seven bytes (byte 1 ... 7).

Format of the output string

Byte No	Function	Value	Comment
0	Length of data string	7	set value
1	Page number	5	hot cathode gauges
2	Status		→ Status byte
3	Error		→ Error byte
4	Measurement high byte	0 ... 255	→ Calculation of pressure value
5	Measurement low byte	0 ... 255	→ Calculation of pressure value
6	Software version	0 ... 255	→ Software version
7	Sensor type	12	for BPG402-Sx
8	Check sum	0 ... 255	→ Synchronization

Synchronization

Synchronization of the master is achieved by testing three bytes:

Byte No	Function	Value	Comment
0	Length of data string	7	set value
1	Page number	5	hot cathode gauges
8	Check sum of bytes No 1 ... 7	0 ... 255	low byte of check sum ¹⁾

¹⁾ High order bytes are ignored in the check sum.

Status byte

Bit 1	Bit 0	Definition
0	0	emission off
0	1	emission 25 μ A
1	0	emission 5 mA
1	1	degas
Bit 2		Definition
x		not used
Bit 3		Definition
0 \leftrightarrow 1		toggle bit, changes with every string received correctly
Bit 5	Bit 4	Definition
0	0	current pressure unit mbar
0	1	current pressure unit Torr
1	0	current pressure unit Pa
Bit 6		Definition
0		filament 1 active
1		filament 2 active
Bit 7		Definition
x		not used

Error byte

Bit 7	Bit 3	Bit 1	Bit 0	Definition
x	x	x	x	not used
Bit 6	Bit 5	Bit 4	Bit 2	Definition
x	x	x	1	Pirani error
x	x	1	x	hot cathode error ²⁾
x	1	x	x	hot cathode warning ³⁾
1	x	x	x	electronics error / EEPROM error

²⁾ Both filaments broken
³⁾ One filament broken

Software version

The software version of the gauge can be calculated from the value of byte 6 of the transmitted string according to the following rule:

$$\text{Version No} = \text{Value}_{\text{Byte 6}} / 20$$

(Example: According to the above formula, Value_{Byte 6} of 32 means software version 1.6)

Calculation of the pressure value

The pressure can be calculated from bytes 4 and 5 of the transmitted string. Depending on the currently selected pressure unit (→ byte 2, bits 4 and 5), the appropriate rule must be applied.

As result, the pressure value results in the usual decimal format.

$$p_{\text{mbar}} = 10^{((\text{high byte} \times 256 + \text{low byte}) / 4000 - 12.5)}$$

$$p_{\text{Torr}} = 10^{((\text{high byte} \times 256 + \text{low byte}) / 4000 - 12.625)}$$

$$p_{\text{Pa}} = 10^{((\text{high byte} \times 256 + \text{low byte}) / 4000 - 10.5)}$$

Example

The example is based on the following output string:

Byte No	0	1	2	3	4	5	6	7	8
Value	7	5	0	0	242	48	20	12	71

The instrument or controller (receiver) interprets this string as follows:

Byte No	Function	Value	Comment
0	Length of data string	7	set value
1	Page number	5	hot cathode gauge
2	Status	0	emission = off pressure unit = mbar filament 1 active
3	Error	0	no error
4	Measurement High byte	242	calculation of the pressure: $p = 10^{((242 \times 256 + 48) / 4000 - 12.5)} = 1000 \text{ mbar}$
5	Low byte	48	
6	Software version	20	software version = 20 / 20 = 1.0
7	Sensor type	12	BPG402-Sx
8	Check sum	71	$5 + 0 + 0 + 242 + 48 + 20 + 12 = 327_{\text{dec}} \triangleq 0147_{\text{hex}}$ High order byte is ignored ⇒ Check sum = $47_{\text{hex}} \triangleq 71_{\text{dec}}$

4.9.1.2 Input String (Receive)

For transmission of the commands to the gauge, a string (frame) of five bytes is sent (without <CR>). Byte 1 ... 3 form the data string.

Format of the input string

Byte no	Function	Value	Comment
0	Length of data string	3	set value
1	Data		→ admissible input strings
2	Data		→ admissible input strings
3	Data		→ admissible input strings
4	Check sum (from bytes No 1 ... 3)	0 ... 255	(low byte of sum) ⁴⁾

⁴⁾ High order bytes are ignored in the check sum.

Admissible input strings

For commands to the gauge, the following strings are defined (values in decimal notation):

Command	Byte No				
	0	1	2	3	4 ⁵⁾
Set the unit mbar in the display	3	16	142	0	158
Set the unit Torr in the display	3	16	142	1	159
Set the unit Pa in the display	3	16	142	2	160
Power-failure-safe storage of current unit	3	32	2	–	34
Switch degas on (switched off automatically after 3 minutes)	3	16	196	1	213
Switch degas off (before 3 minutes)	3	16	196	0	212
Set Emission Control Mode to AUTO ⁶⁾	3	16	138	1	155
Set Emission Control Mode to MAN ⁶⁾	3	16	138	0	154
Power-failure-safe storage of the Emission Control Mode ⁶⁾	3	32	1	–	33
Switch emission on	3	64	16	1	81
Switch emission off	3	64	16	0	80
Set Filament Control Mode to AUTO ⁷⁾	3	16	211	0	227
Set Filament Control Mode to MAN ⁷⁾	3	16	211	1	228
Power-failure-safe storage of the Filament Control Mode ⁷⁾	3	32	13	–	45
Select filament 1 ⁸⁾	3	16	210	0	226
Select filament 2 ⁸⁾	3	16	210	1	227
Power-failure-safe storage of selected filament ⁸⁾	3	32	12	–	44
Read filament status	3	0	212	–	212
Read software version	3	0	209	–	209
Reset	3	64	0	0	64

⁵⁾ Only low order byte of sum (high order byte is ignored).

⁶⁾ Defines the Emission Control Mode (→ ¶ 29):
 AUTO = emission on/off automatically controlled by the gauge
 MAN = emission on/off controlled via interfaces.

⁷⁾ Defines the Filament Control Mode (→ ¶ 29):
 AUTO = Selection of filament automatically controlled by the gauge
 MAN = Selection of filament controlled via interfaces.

⁸⁾ The "Select filament x" command can be sent any time but is only executed if the gauge is in the "Emission OFF" state.

4.10 DeviceNet Interface (BPG402-SD)

This interface allows operation of BPG402-SD with part number 353-576 and 353-577

in connection with other devices that are suited for DeviceNet operation. The physical interface and communication firmware of BPG402-SD comply with the DeviceNet standard (→ [4], [6]).

Two adjustable switching functions are integrated in BPG402-SD. The corresponding relay contacts are available at the sensor cable connector (→ 8, 20, 37).

The basic sensor and sensor electronics of all BPG402 gauges are identical.

Caution

Caution: data transmission errors
 If the gauge is operated via RS232C interface and DeviceNet interface at the same time, data transmission errors may occur.
 The gauge must not be operated via RS232C interface and DeviceNet interface at the same time.

4.10.1 Description of the Functions

Via this interface, the following and further data are exchanged in the standardized DeviceNet protocol (→ [1]):

- Pressure reading
- Pressure unit (Torr, mbar, Pa)
- Degas function
- Gauge adjustment
- Status and error messages
- Status of the switching functions

4.10.2 Operating Parameters

As the DeviceNet protocol is highly complex, the parameters and programming of BPG402-SD are described in detail in the separate Communication Protocol (→ [1]).

4.10.2.1 Operating Software

Before the gauge is put into operation, it has to be configured for DeviceNet operation. A configuration tool and the device specific EDS file (Electronic Data Sheet) are required for this purpose. The EDS file can be downloaded via internet (→ [3]).

4.10.2.2 Node Address Setting

For unambiguous identification of the gauge in a DeviceNet environment, a node address is required. The node address setting is made on the gauge or programmed via DeviceNet.

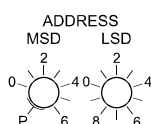

Set the node address (0 ... 63_{dec}) via the "ADDRESS" "MSD" and "LSD" switches. The node address is polled by the firmware when the gauge is switched on. If the setting deviates from the stored value, the new value is taken over into the NVRAM. If a setting higher than 63 is made, the previous node address setting remains valid.

Default address setting is 63_{dec}.

If the „MSD“ switch is in the "P" position, the node address is programmable via DeviceNet (→ [1]).

4.10.2.3 Data Rate Setting

The admissible data rate depends on a number of factors such as system parameters and cable length (→ [4], [6]). It can be set on the gauge or programmed via DeviceNet.



By means of the "RATE" switch, the data rate can be set to 125 ("1"), 250 ("2") or 500 kBaud ("5").

Default data rate setting is 500 kBaud.

If the switch is in any of the "P" positions, the data rate is programmable via DeviceNet (→ [1]).

4.10.3 Status Indicators

Two LEDs on the gauge inform on the gauge status and the current DeviceNet status.



"STATUS MOD"
(gauge status):

LED	Description
Dark	no supply
Red/green, flashing	self test
Green	normal operation
Red	non recoverable error

"STATUS NET"
(network status):

LED	Description
Dark	gauge not online: <ul style="list-style-type: none"> – self test not yet concluded – no supply, → "STATUS MOD" LED
Green, flashing	gauge online but no communication: <ul style="list-style-type: none"> – self test concluded but no communication to other nodes established – gauge not assigned to any master
Green	gauge online; necessary connections established
Red, flashing	one or several input / output connections in "time out" status
Red	communication error. The gauge has detected an error that impedes communication via the network (e.g. two identical node addresses (MAC IC) or "Bus-off")

Electrical connections

The gauge is connected to the DeviceNet system via the 5-pin DeviceNet connector (→ 21).

4.11 Profibus Interface (BPG402-SP)

This interface allows operation of BPG402-SP with part number 353-574 and 353-575

in connection with other devices that are suited for Profibus operation. The physical interface and communication firmware of BPG402-SP comply with the Profibus standard (→ [5], [7]).

Two adjustable switching functions are integrated in the BPG402-SP. The corresponding relay contacts are available at the sensor cable connector (→ 8, 20, 37).

The basic sensor and sensor electronics of all BPG402 gauges are identical.

Caution

Caution: data transmission errors
 If the gauge is operated via RS232C interface and Profibus interface at the same time, data transmission errors may occur.
 The gauge must not be operated via RS232C interface and Profibus interface at the same time.

4.11.1 Description of the Functions

Via this interface, the following and further data are exchanged in the standardized Profibus protocol (→ [2]):

- Pressure reading
- Pressure unit (Torr, mbar, Pa)
- Degas function
- Gauge adjustment
- Status and error messages
- Status of the switching functions

4.11.2 Operating Parameters

As the DeviceNet protocol is highly complex, the parameters and programming of BPG402-SP are described in detail in the separate Communication Protocol (→ [2]).

4.11.2.1 Operating Software

For operating the gauge via Profibus, prior installation of the BPG402-SP specific GSD file is required on the bus master side. This file can be downloaded via internet (→ [3]).

4.11.2.2 Node Address Setting

For unambiguous identification of the gauge in a Profibus environment, a node address is required. The node address setting is made on the gauge.

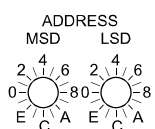

The node address (0 ... 125_{dec}) is set in hexadecimal form (00 ... 7D_{hex}) via the "ADDRESS", "MSD", and "LSD" switches. The node address is polled by the firmware when the gauge is switched on. If the setting deviates from the stored value, the new value is taken over into the NVRAM. If a value >7D_{hex} (>125_{dec}) is entered, the node address setting currently stored in the device remains valid but it can now be defined via Profibus ("Set slave Address", → [2]).
 Default address setting is 5C_{hex}.

Electrical connections

The gauge is connected to Profibus via the 9-pin Profibus connector (→ 22).

4.12 Switching Functions

The BPG402-S has one, the gauges BPG402-SD and BPG402-SP have two independent, manually adjustable switching functions. Each switching function has a floating, normally open relay contact. The relay contacts are accessible at the sensor cable connector (→ 19, 20).

The threshold values of the switching functions can be set within the pressure range 1×10^{-9} mbar ... 100 mbar via potentiometers "SETPOINT" (BPG402-S) or "SETPOINT A" and "SETPOINT B" (BPG402-SD, BPG402-SP).

The following rule applies:

$$U_{\text{Threshold}} = 0.75 \times (\log p_{\text{Setpoint}} - c) + 7.75$$

Where constant c is pressure unit dependent (→ Appendix A).

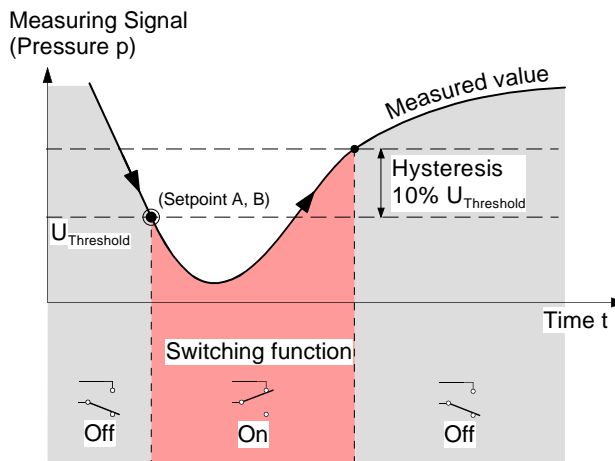

The hysteresis of the switching functions is 10% of the threshold setting.

4.12.1 Setting the Switching Functions

The threshold values of the switching functions are set locally on the potentiometers of the gauge that are accessible via the openings on one side of the gauge housing.

Required tools

- Voltmeter
- Ohmmeter or continuity checker
- Screwdriver, max. $\varnothing 2.5$ mm

Procedure

The procedure for setting thresholds is identical for all switching functions.

- 1 Put the gauge into operation.
- 2 Connect the + lead of a voltmeter to the threshold measurement point of the respective switching function (Pin 3 or Pin 6).
Connect the – lead of the voltmeter to a ground contact nearby (e.g. locking screw of the connector, vacuum flange or housing of the gauge).



The threshold voltages are referenced to ground (housing, vacuum connection), **not** to Pin 5 (common power GND 24 V supply).

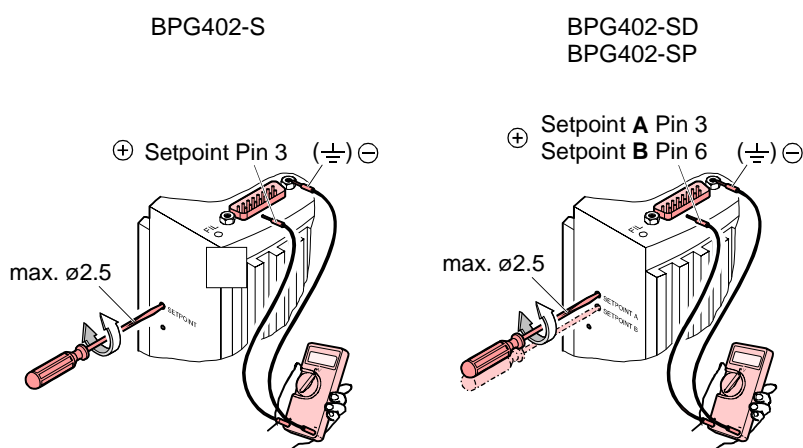

- 3 Using a screwdriver (max. $\varnothing 2.5$ mm), set the voltage of the selected switching function to the desired value $U_{\text{Threshold}}$.



There is no local visual indication of the status of the switching functions. However, a functional check of the switching functions (On/Off) can be made with one of the following methods:

- Reading the status via fieldbus interface, for BPG402-SD → [1], for BPG402-SP → [2].
- Measurement of the relay contacts at the sensor cable connector with an ohmmeter / continuity checker (→ 19, 20).

5 Deinstallation



DANGER

DANGER: contaminated parts
Contaminated parts can be detrimental to health and environment. Before beginning to work, find out whether any parts are contaminated. Adhere to the relevant regulations and take the necessary precautions when handling contaminated parts.



Caution



Caution: vacuum component
Dirt and damages impair the function of the vacuum component. When handling vacuum components, take appropriate measures to ensure cleanliness and prevent damages.



Caution



Caution: dirt sensitive area
Touching the product or parts thereof with bare hands increases the desorption rate. Always wear clean, lint-free gloves and use clean tools when working in this area.

Procedure

- 1 Vent the vacuum system.



Before taking the gauge out of operation, make sure that this has no adverse effect on the vacuum system. Depending on the programming of the superset controller, faults may occur or error messages may be triggered. Follow the appropriate shut-down and starting procedures.

- 2 Take gauge out of operation, switch power supply off.
- 3 Disconnect all cables from the gauge.

- 4 Remove gauge from the vacuum system and replace the protective lid.

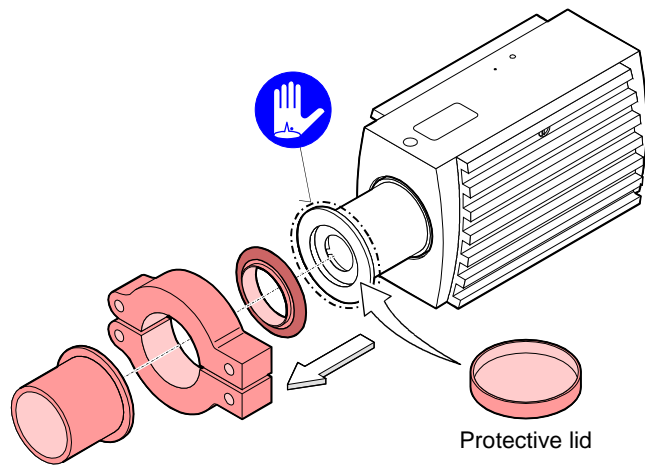

6 Maintenance, Repair



DANGER

DANGER: contaminated parts

Contaminated parts can be detrimental to health and environment.

Before beginning to work, find out whether any parts are contaminated. Adhere to the relevant regulations and take the necessary precautions when handling contaminated parts.

6.1 Cleaning the Gauge

Small deposits on the electrode system can be removed by baking the anode (Degas → 27). In the case of severe contamination, the baffle can be exchanged easily (→ 15). The sensor itself cannot be cleaned and needs to be replaced in case of severe contamination (→ 44).

A slightly damp cloth normally suffices for cleaning the outside of the unit. Do not use any aggressive or scouring cleaning agents.



Make sure that no liquid can penetrate the product. Allow the product to dry thoroughly before putting it into operation again.



Gauge failures due to contamination, as well as expendable parts (filament), are not covered by the warranty.

6.2 Adjusting the Gauge

The gauge is factory-calibrated. Through the use in different climatic conditions, fitting positions, aging or contamination (→ 27) and after exchanging the sensor (→ 44) a shifting of the characteristic curve can occur and readjustment can become necessary. Only the Pirani part can be adjusted.

6.2.1 Adjustment at Atmospheric Pressure

At the push of a button the digital value and thus the analog output are adjusted electronically to +10 V (1000 mbar) at atmospheric pressure.

Adjustment is necessary if

- at atmospheric pressure, the measured value is < atmospheric pressure.
- venting the system, the measured value reaches its maximum before the actual pressure has reached atmospheric pressure.

This applies to the analog output signal, the pressure value indicated by the gauges featuring a display and the pressure value output by the digital interfaces.

Required tools

- Pin approx. $\varnothing 1.3 \times 50$ mm (e.g. a bent open paper clip)

Procedure



Operate gauge for approx. 10 minutes at atmospheric pressure.



If the gauge was operated before in the Bayard-Alpert range, a cooling-down time of approx. 30 minutes is to be expected (gauge temperature = ambient temperature).

- 2** Insert the pin through the opening shown in the following illustration and push the button inside for 1 s.

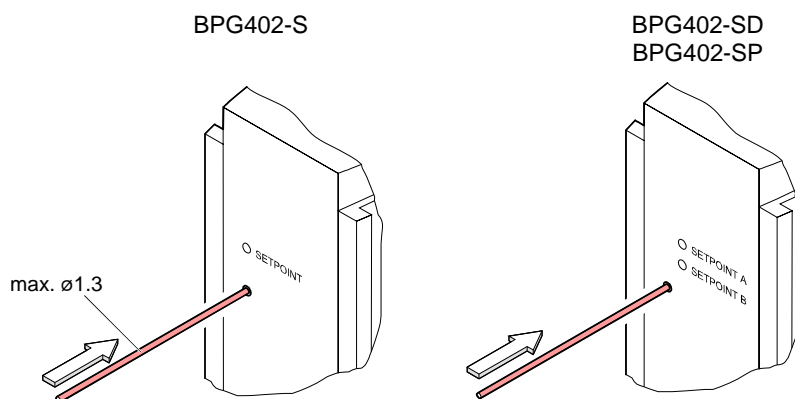

Gauges with display will show the reading "1000 mbar".

6.2.2 Zero Point Adjustment

Zero point readjustments are automatically carried out during operation of the gauge, no manual adjustment is needed.

6.3 What to Do in Case of Problems

Required tools / material

- Voltmeter / ohmmeter
- Allen wrench, AF 2.5
- Spare sensor (if the sensor is faulty)

Troubleshooting (Gauge)

The output signal is available at the sensor cable connector (Pin 2 and Pin 12).



In case of an error, it may be helpful to just turn off the mains supply and turn it on again after 5 s.

Problem	Possible cause	Correction
Output signal permanently $\approx 0V$	Sensor cable defective or not correctly connected	Check the sensor cable
	No supply voltage	Turn on the power supply
	Gauge in an undefined status	Turn the gauge off and on again (reset)
Output signal $\approx +0.1 V$ (Display: "FAI L EL")	EEPROM failure	Turn the gauge off and on again after 5 s Replace the electronics unit
Output signal $\approx +0.3 V$ (Display: "FAI L I on")	Hot cathode error (sensor defective) → also ¶ 28, filament status	Replace the sensor (→ ¶ 44) 1)
Output signal $\approx +0.5 V$ (Display: "FAI L Pi r")	Pirani error (sensor defective)	Replace the sensor (→ ¶ 44)
	Electronics unit not mounted correctly on sensor	Check the connections (Electronics — sensor)
Corrupted or no signal Display: "no Si gnal "	Internal data connection not working	Turn the gauge off and on again after 5 s Replace the electronics unit

1) Pressing the button on the side of the gauge will reset the filament status (only in the hot cathode range). Subsequently the gauge will test the filaments again (test time ≈ 8 sec. / filament). If the error still exists, the gauge will immediately return into the error state.

Troubleshooting (sensor)

If the cause of a fault is suspected to be in the sensor, the following checks can be made with an ohmmeter (the vacuum system need not be vented for this purpose). Separate the sensor from the electronics unit (→ ¶ 14). Using an ohmmeter, make the following measurements on the contact pins.



All unmarked pins in the diagram are used by the sensor electronics and cannot be utilized for diagnostic purposes (do not connect an ohmmeter / continuity checker to these pins).

Ohmmeter measurement between pins			Possible cause
2 + 4	$\approx 37 \Omega$	$\gg 37 \Omega$	Pirani element 1 broken
4 + 5	$\approx 37 \Omega$	$\gg 37 \Omega$	Pirani element 2 broken
6 + 7	$\approx 0.15 \Omega$	$\gg 0.15 \Omega$	Filament 1 of hot cathode broken ¹⁾
7 + 8	$\approx 0.15 \Omega$	$\gg 0.15 \Omega$	Filament 2 of hot cathode broken ¹⁾
4 + 1	∞	$\ll \infty$	Electrode - short circuit to ground
6/7/8 + 1	∞	$\ll \infty$	Electrode - short circuit to ground
3 + 1	∞	$\ll \infty$	Electrode - short circuit to ground
9 + 1	∞	$\ll \infty$	Electrode - short circuit to ground
6/7/8 + 3	∞	$\ll \infty$	Short circuit between electrodes
9 + 3	∞	$\ll \infty$	Short circuit between electrodes

1) → also "Filament Status", ¶ 28).

View on sensor pins

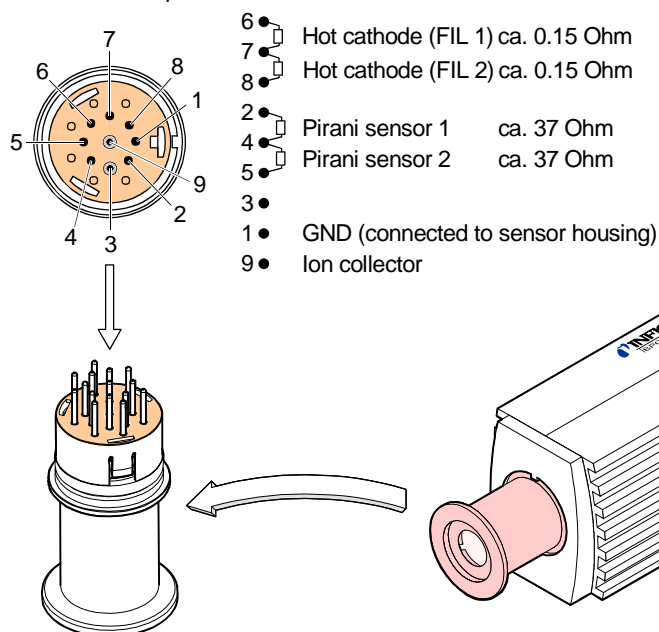

Correction

All of the above faults can only be remedied by replacing the sensor (→ 44).

Troubleshooting on Fieldbus gauges (BPG402-SD, -SP)

Error diagnosis of fieldbus gauges can only be performed as described above for the basic sensor and sensor electronics. Diagnosis of the fieldbus interface can only be done via the corresponding bus controller (→ [1], [2]).

For diagnosis of the BPG402-SD (DeviceNet) gauges, the built in LEDs might produce some useful information (→ 35).

6.4 Replacing the Sensor

Replacement is necessary, when

- the sensor is severely contaminated
- the sensor is mechanically deformed
- the sensor is faulty, e.g. one / both filaments of hot cathode broken (→ 42)
- the sensor is faulty, e.g. Pirani element broken (→ 42)



INFICON recommends the replacement of the sensor as soon as the first filament failure has been detected.

Required tools / material

- Allen wrench, AF 2.5
- Spare sensor (→ 45)

Procedure

- 1 Deinstall the gauge (→ 39).
- 2 Deinstall the electronics unit from the faulty sensor and mount it to the new sensor (→ 14).
- 3 Adjust the gauge (→ 41).

7 Options

	Ordering number
24 VDC power supply / RS232C line (→ 23)	353-511
Baffle DN 25 ISO-KF / DN 40 CF-R (→ 15)	353-512

8 Spare Parts

When ordering spare parts, always indicate:

- All information on the product nameplate
- Description and part number

	Ordering number
Replacement sensor BPG402-Sx, DN 25 ISO-KF (including allen wrench)	354-494
Replacement sensor BPG402-Sx, DN 40 CF-R (including allen wrench)	354-495

9 Storage



Caution



Caution: vacuum component

Inappropriate storage leads to an increase of the desorption rate and/or may result in mechanical damage of the product.

Cover the vacuum ports of the product with protective lids or grease free aluminum foil. Do not exceed the admissible storage temperature range (→ 11).

10 Returning the Product

WARNING

WARNING: forwarding contaminated products
Contaminated products (e.g. radioactive, toxic, caustic or biological hazard) can be detrimental to health and environment.

Products returned to INFICON should preferably be free of harmful substances. Adhere to the forwarding regulations of all involved countries and forwarding companies and enclose a duly completed declaration of contamination (→ 51).

Products that are not clearly declared as "free of harmful substances" are decontaminated at the expense of the customer.

Products not accompanied by a duly completed declaration of contamination are returned to the sender at his own expense.

11 Disposal

DANGER

DANGER: contaminated parts
Contaminated parts can be detrimental to health and environment.

Before beginning to work, find out whether any parts are contaminated. Adhere to the relevant regulations and take the necessary precautions when handling contaminated parts.

WARNING

WARNING: substances detrimental to the environment
Products or parts thereof (mechanical and electric components, operating fluids etc.) can be detrimental to the environment.

Dispose of such substances in accordance with the relevant local regulations.

Separating the components

After disassembling the product, separate its components according to the following criteria:

Contaminated components

Contaminated components (radioactive, toxic, caustic or biological hazard etc.) must be decontaminated in accordance with the relevant national regulations, separated according to their materials, and disposed of.

Other components

Such components must be separated according to their materials and recycled.

Appendix

A: Relationship Output Signal – Pressure

Conversion formulae

$$p = 10^{(U - 7.75) / 0.75 + c}$$

$$U = 0.75 \times (\log p - c) + 7.75$$

where

U	p	c
[V]	[mbar]	0
[V]	[Pa]	2
[V]	[Torr]	-0.125

Conversion curve

Pressure p [mbar]

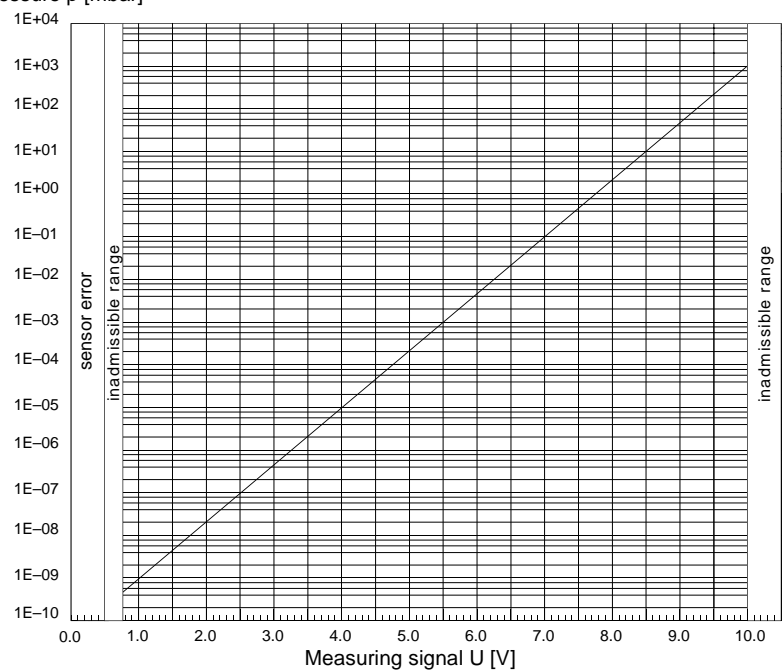

Conversion table

Output signal U [V]	Pressure p		
	[mbar]	[Torr]	[Pa]
0.1 / 0.3 / 0.5	Sensor error (→ 42)		
0.51 ... 0.774	Inadmissible range		
0.774	5×10^{-10}	3.75×10^{-10}	5×10^{-8}
1.00	1×10^{-9}	7.5×10^{-10}	1×10^{-7}
1.75	1×10^{-8}	7.5×10^{-9}	1×10^{-6}
2.5	1×10^{-7}	7.5×10^{-8}	1×10^{-5}
3.25	1×10^{-6}	7.5×10^{-7}	1×10^{-4}
4.00	1×10^{-5}	7.5×10^{-6}	1×10^{-3}
4.75	1×10^{-4}	7.5×10^{-5}	1×10^{-2}
5.50	1×10^{-3}	7.5×10^{-4}	1×10^{-1}
6.25	1×10^{-2}	7.5×10^{-3}	1×10^0
7.00	1×10^{-1}	7.5×10^{-2}	1×10^1
7.75	1×10^0	7.5×10^{-1}	1×10^2
8.50	1×10^1	7.5×10^0	1×10^3
9.25	1×10^2	7.5×10^1	1×10^4
10.00	1×10^3	7.5×10^2	1×10^5
>10.00	Inadmissible range		

B: Gas Type Dependence

Indication range
above 10^{-2} mbar

Pressure indicated (gauge adjusted for air, Pirani-only mode)

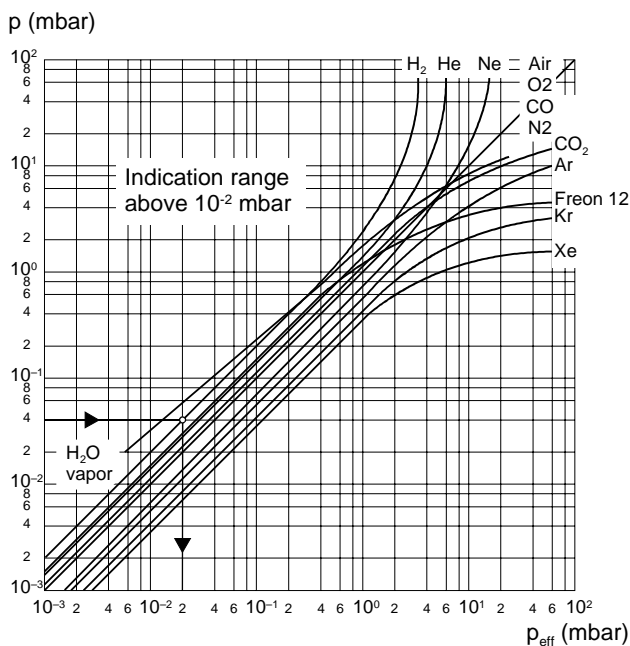

Calibration in pressure range
 10^{-2} ... 1 mbar

The gas type dependence in the pressure range 10^{-2} ... 1 mbar (Pirani pressure range) can be compensated by means of the following formula:

$$p_{\text{eff}} = C \times \text{indicated pressure}$$

where

Gas type	Calibration factor C
Air, O ₂ , CO	1.0
N ₂	0.9
CO ₂	0.5
Water vapor	0.7
Freon 12	1.0
H ₂	0.5
He	0.8
Ne	1.4
Ar	1.7
Kr	2.4
Xe	3.0

(The above calibration factors are mean values)

Calibration in pressure range
 $<10^{-3}$ mbar

The gas type dependence in the pressure range $<10^{-3}$ mbar can be compensated by means of the following formula (gauge adjusted for air):

$$p_{\text{eff}} = C \times \text{indicated pressure}$$









where	Gas type	Calibration factor C
	Air, O ₂ , CO, N ₂	1.0
	N ₂	1.0
	He	5.9
	Ne	4.1
	H ₂	2.4
	Ar	0.8
	Kr	0.5
	Xe	0.4

(The above calibration factors are mean values.)



A mixture of gases and vapors is often involved. In this case, accurate determination is only possible with a partial-pressure measuring instrument.

C: Literature

-  [1] www.inficon.com
 Communication Protocol
 DeviceNet™ BPG402-SD
 tira46e1
 INFICON AG, LI-9496 Balzers, Liechtenstein
-  [2] www.inficon.com
 Communication Protocol
 Profibus BPG402-SP
 tira47e1
 INFICON AG, LI-9496 Balzers, Liechtenstein
-  [3] www.inficon.com
 Product descriptions and downloads
 INFICON AG, LI-9496 Balzers, Liechtenstein
-  [4] www.odva.org
 Open DeviceNet Vendor Association, Inc.
 DeviceNet™ Specifications
-  [5] www.profibus.com
 Profibus user organization
-  [6] European Standard for DeviceNet, EN 50325
-  [7] European Standard for Profibus, EN 50170
-  [8] www.inficon.com
 Instruction Sheet
 BPG402-S, BPG402-SD, BPG402-SP
 tima46e1
 INFICON AG, LI-9496 Balzers, Liechtenstein
-  [9] www.inficon.com
 Instruction Sheet
 BPG402-SD, BPG402-SP
 tima47e1
 INFICON AG, LI-9496 Balzers, Liechtenstein

Declaration of Contamination

The service, repair, and/or disposal of vacuum equipment and components will only be carried out if a correctly completed declaration has been submitted. Non-completion will result in delay.

This declaration may only be completed (in block letters) and signed by authorized and qualified staff.

1 Description of product
 Type _____
 Part number _____
 Serial number _____

2 Reason for return

3 Operating fluid(s) used (Must be drained before shipping.)

4 Used in copper process
 no yes → Seal product in plastic bag and mark it with a corresponding label.

5 Process related contamination of product:

toxic	no <input type="checkbox"/> 1)	yes <input type="checkbox"/>	 2) Products thus contaminated will not be accepted without written evidence of decontamination.
caustic	no <input type="checkbox"/> 1)	yes <input type="checkbox"/>	
biological hazard	no <input type="checkbox"/>	yes <input type="checkbox"/> 2)	
explosive	no <input type="checkbox"/>	yes <input type="checkbox"/> 2)	
radioactive	no <input type="checkbox"/>	yes <input type="checkbox"/> 2)	
other harmful substances	no <input type="checkbox"/> 1)	yes <input type="checkbox"/>	

1) or not containing any amount of hazardous residues that exceed the permissible exposure limits

The product is free of any substances which are damaging to health.
 yes

6 Harmful substances, gases and/or by-products
 Please list all substances, gases, and by-products which the product may have come into contact with:

Trade/product name	Chemical name (or symbol)	Precautions associated with substance	Action if human contact

7 Legally binding declaration:
 We hereby declare that the information on this form is complete and accurate and that we will assume any further costs that may arise. The contaminated product will be dispatched in accordance with the applicable regulations.

Organization/company _____

Address _____ Post code, place _____

Phone _____ Fax _____

Email _____

Name _____

Date and legally binding signature _____ Company stamp _____

This form can be downloaded from our website.

Copies: Original for addressee - 1 copy for accompanying documents - 1 copy for file of sender

Original: German tina46d1 (2006-07)



tina46d1



*LI-9496 Balzers
Liechtenstein
Tel +423 / 388 3111
Fax +423 / 388 3700
reachus@inficon.com*

www.inficon.com