

TripleGauge™

Bayard-Alpert Pirani Capacitance Diaphragm Gauge

BCG450

BCG450-SD

BCG450-SP

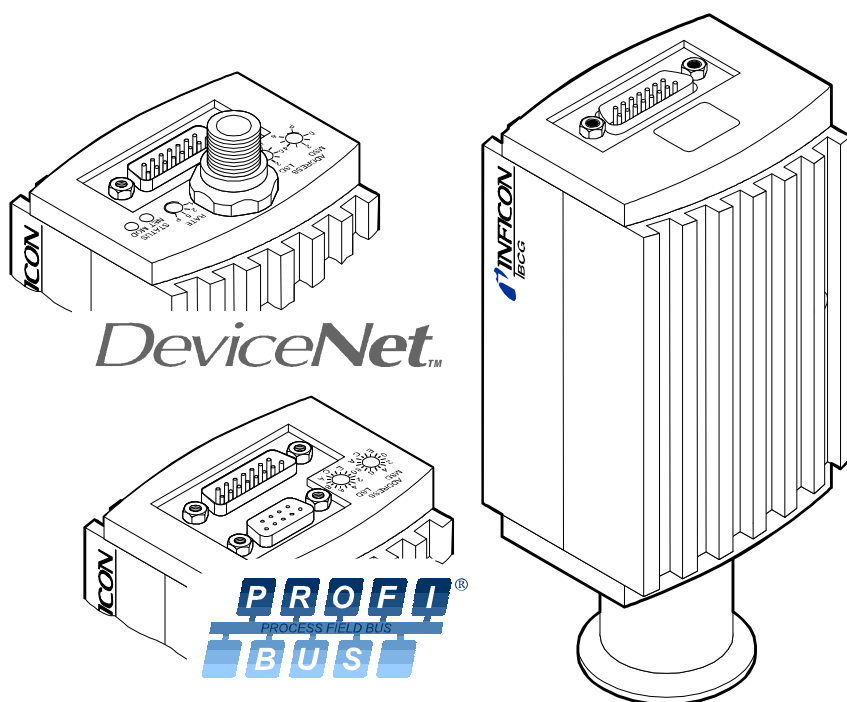

Product Identification

In all communications with INFICON, please specify the information on the product nameplate. For convenient reference copy that information into the space provided below.

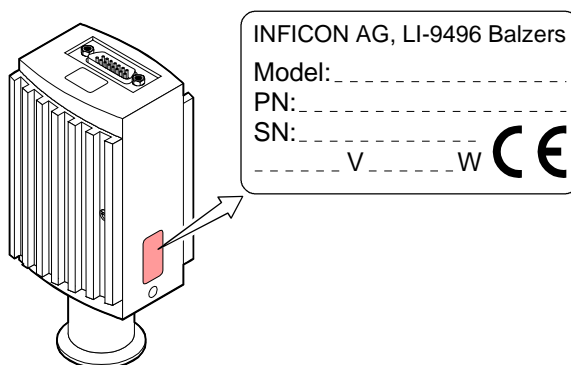

Validity

This document applies to products with the following part numbers:

BCG450 (without display)

353-550 (vacuum connection DN 25 ISO-KF)
353-551 (vacuum connection DN 40 CF-R)

BCG450 (with display)

353-552 (vacuum connection DN 25 ISO-KF)
353-553 (vacuum connection DN 40 CF-R)

BCG450-SD (with DeviceNet interface and switching functions)

353-557 (vacuum connection DN 25 ISO-KF)
353-558 (vacuum connection DN 40 CF-R)



BCG450-SP (with Profibus interface and switching functions)

353-554 (vacuum connection DN 25 ISO-KF)
353-556 (vacuum connection DN 40 CF-R)

The part number (PN) can be taken from the product nameplate.



If not indicated otherwise in the legends, the illustrations in this document correspond to gauge with part number 353-552. They apply to the other gauges by analogy.

All BCG450 versions are shipped with an instruction sheet (→  [8]). BCG450-SD and BCG450-SP come with a supplementary instruction sheet describing the field-bus interfaces and the switching functions (→  [9]).

We reserve the right to make technical changes without prior notice.

Intended Use

The BCG450, BCG450-SD and BCG450-SP gauges have been designed for vacuum measurement of non-flammable gases and gas mixtures in a pressure range of 5×10^{-10} ... 1500 mbar.

The gauges can be operated in connection with the INFICON Vacuum Gauge Controller VGC401, VGC402 or VGC403 or with other control devices.

Functional Principle

Due to the combination of three sensor technologies incorporated in the gauge (Capacitance diaphragm sensor, Pirani sensor and hot cathode ionisation sensor (BA)), a minimized gas type dependence is achieved.

Between 10 mbar and atmospheric pressure, the capacitance diaphragm sensor operates without any gas type dependence. Below 1 mbar, the Pirani sensor and the hot cathode ionisation sensor take over with only a small gas type dependence.

Between 1 ... 10 mbar and 5×10^{-3} ... 2×10^{-2} mbar the gauges built in electronic circuits take care of continuous and smooth crossovers between the ranges. Over the whole measurement range, the measurement signal is output as a logarithm of the pressure.

The hot cathode is switched on by the Pirani measurement system only below the switching threshold of 2.4×10^{-2} mbar (to prevent filament burn-out). It is switched off when the pressure exceeds 3.2×10^{-2} mbar.

Gauge adjustment is carried out automatically, no manual adjustment is required.

A user programmable atmospheric pressure switching function is incorporated.



Trademarks

DeviceNet™ Open DeviceNet Vendor Association, Inc.
TripleGauge™ INFICON AG, Balzers

Contents

Product Identification	2
Validity	2
Intended Use	2
Functional Principle	3
Trademarks	3
1 Safety	6
1.1 Symbols Used	6
1.2 Personnel Qualifications	6
1.3 General Safety Instructions	7
1.4 Liability and Warranty	7
2 Technical Data	8
3 Installation	13
3.1 Vacuum Connection	13
3.1.1 Removing and Installing the Electronics Unit	15
3.1.2 Using the Optional Baffle	16
3.2 Electrical Connection	17
3.2.1 Use With INFICON VGC40x Vacuum Gauge Controller	17
3.2.2 Use With Other Controllers	18
3.2.2.1 Making an Individual Sensor Cable	18
3.2.2.2 Making a DeviceNet Interface Cable (BCG450-SD)	21
3.2.2.3 Making a Profibus Interface Cable (BCG450-SP)	22
3.2.3 Using the Optional Power Supply (With RS232C Line)	23
4 Operation	25
4.1 Measuring Principle, Measuring Behavior	25
4.2 Operational Principle of the Gauge	27
4.3 Putting the Gauge Into Operation	28
4.4 Degas	28
4.5 Emission Control Mode	29
4.6 Atmosphere Switching Function	30
4.6.1 Functional Principle	30
4.6.2 Programming the Atmospheric Pressure Threshold	31
4.6.3 Wiring the relay "Atmospheric Pressure Reached" (BCG450)	32
4.7 Display (BCG450)	33
4.8 RS232C Interface	34
4.8.1 Description of the Functions	35
4.8.1.1 Output String (Transmit)	35
4.8.1.2 Input String (Receive)	37
4.9 DeviceNet Interface (BCG450-SD)	39
4.9.1 Description of the Functions	39
4.9.2 Operating Parameters	39
4.9.2.1 Operating Software	39
4.9.2.2 Node Address Setting	39
4.9.2.3 Data Rate Setting	40
4.9.3 Status Lights	40
4.10 Profibus Interface (BCG450-SP)	41
4.10.1 Description of the Functions	41
4.10.2 Operating Parameters	41
4.10.2.1 Operating Software	41
4.10.2.2 Node Address Setting	41
4.11 Switching Functions (BCG450-SD, -SP)	42
4.11.1 Setting the Switching Functions	42
5 Deinstallation	44
6 Maintenance, Repair	46
6.1 Maintenance	46
6.1.1 Cleaning the Gauge	46

6.2	Adjusting the Gauge	46
6.3	Adjusting the Atmosphere Sensor	46
6.3	What to Do in Case of Problems	48
6.4	Replacing the Sensor	50
7	Options	51
8	Spare Parts	51
9	Storage	51
10	Returning the Product	52
11	Disposal	52
	Appendix	53
A:	Relationship Measuring Signal – Pressure	53
B:	Gas Type Dependence	54
C:	Literature	56
	Declaration of Contamination	57

For cross-references within this document, the symbol (→  XY) is used, for cross-references to further documents and data sources, the symbol (→  [Z]).

1 Safety

1.1 Symbols Used

DANGER

Information on preventing any kind of physical injury.

WARNING

Information on preventing extensive equipment and environmental damage.

Caution

Information on correct handling or use. Disregard can lead to malfunctions or minor equipment damage.



Notice



Hint, recommendation



The result is O.K.



The result is not as expected.



Optical inspection



Waiting time, reaction time

1.2 Personnel Qualifications

Skilled personnel

All work described in this document may only be carried out by persons who have suitable technical training and the necessary experience or who have been instructed by the end-user of the product.

1.3 General Safety Instructions

- Adhere to the applicable regulations and take the necessary precautions for the process media used.
Consider possible reactions between the materials (→ 11) and the process media.
Consider possible reactions of the process media (e.g. explosion) due to the heat generated by the product.
- Adhere to the applicable regulations and take the necessary precautions for all work you are going to do and consider the safety instructions in this document.
- Before beginning to work, find out whether any vacuum components are contaminated. Adhere to the relevant regulations and take the necessary precautions when handling contaminated parts.

Communicate the safety instructions to all other users.

1.4 Liability and Warranty

INFICON assumes no liability and the warranty becomes null and void if the end-user or third parties

- disregard the information in this document
- use the product in a non-conforming manner
- make any kind of interventions (modifications, alterations etc.) on the product
- use the product with accessories not listed in the corresponding product documentation.

The end-user assumes the responsibility in conjunction with the process media used.

2 Technical Data

Measurement principle	Pressure range	
	10 ... 1500 mbar	capacitance diaphragm sensor
	1 ... 10 mbar	crossover range
	2×10^{-2} ... 1 mbar	Pirani sensor
	5×10^{-3} ... 2×10^{-2} mbar	crossover range
	5×10^{-10} ... 5×10^{-3} mbar	hot cathode ionisation (BA)
Measuring range	Range (air, O ₂ , CO, N ₂)	5×10^{-10} ... 1500 mbar, continuous
	Accuracy	
	1 × 10 ⁻⁸ ... 50 mbar	15% of reading
	50 ... 950 mbar	5% of reading
	950 ... 1050 mbar	2.5% of reading (after 10 min. stabilisation)
	Repeatability	5% of reading, 10 ⁻⁸ ... 10 ⁻² mbar (after 10 min. stabilisation)
	Gas type dependence	→ Appendix B
Emission	Switching on threshold	2.4×10^{-2} mbar
	Switching off threshold	3.2×10^{-2} mbar
	Emission current	
	$p \leq 7.2 \times 10^{-6}$ mbar	5 mA
	7.2×10^{-6} mbar < $p < 3.2 \times 10^{-2}$ mbar	25 μA
	Emission current switching	
	25 μA ⇒ 5 mA	7.2×10^{-6} mbar
	5 mA ⇒ 25 μA	3.0×10^{-5} mbar
Degas	Degas emission current ($p < 7.2 \times 10^{-6}$ mbar)	≈20 mA ($P_{\text{degas}} \approx 4$ W)
	Control input signal	0 V/+24 VDC, active high (control via RS232 → 34)
	Duration	max. 3 min, followed by automatic stop A new degas cycle can only be started after a waiting time of 30 minutes.
		In degas mode, BCG450 gauges keep supplying measurement values, however their tolerances may be higher than during normal operation.
Output signal	Output signal (measuring signal)	0 ... +10.13 V
	Measuring range	0.774 V (5×10^{-10} mbar) ... +10.13 V (1500 mbar)
	Relationship voltage-pressure	logarithmic, 0.75 V/decade (→ Appendix A)
	Error signal	+0.1 V Diaphragm sensor or EEPROM error +0.3 V BA sensor error +0.5 V Pirani sensor error (→ 48)
		Minimum load impedance

Display (BCG450)

Display panel	LCD matrix, 32x16 pixels
Background illumination	two colors red/green
Dimensions	16.0 mm x 11.2 mm
Pressure units (pressure p)	mbar (default), Torr, Pa (selecting the pressure unit → 34)

Power supply

DANGER

The gauge must only be connected to power supplies, instruments or control devices that conform to the requirements of a grounded extra-low voltage (SELV-E according to EN 61010). The connection to the gauge has to be fused (INFICON-controllers fulfill these requirements).

Operating voltage at the gauge	+24 VDC (+20 ... +28 VDC) ¹⁾ ripple max. 2 V _{pp}
Power consumption	
Standard	≤0.5 A
Degas	≤0.9 A
Emission start (<200 ms)	≤1.4 A
Power consumption	
BCG450	≤18 W
BCG450-SD	≤20 W
BCG450-SP	≤20 W
Fuse necessary	1.25 AT



BCG450-SD requires an additional, separate power supply for the DeviceNet interface (→ 21).

Supply voltage at the DeviceNet connector, (Pin 2 and Pin 3)	+24 VDC (+11 ... +25 VDC)
Power consumption	<2 W

The gauge is protected against reversed polarity of the supply voltage.

Sensor cable connection



For reasons of compatibility, the expression "sensor cable" is used for all BCG450 versions in this document, although the pressure reading of the gauges with fieldbus interface (BCG450-SD and BCG450-SP) is normally transmitted via the corresponding bus.

Electrical connector	D-Sub, 15 pins, male
BCG450	→ 19
BCG450-SD, -SP	→ 20
Measuring cable	shielded, number of conductors depending on the functions used (max. 15 conductors plus shielding)
Cable length (supply voltage 24 V ¹⁾)	
Analog and fieldbus operation	≤35 m, conductor cross-section 0.25 mm ² ≤50 m, conductor cross-section 0.34 mm ² ≤100 m, conductor cross-section 1.0 mm ²
RS232C operation	≤30 m
Gauge identification	42 kΩ resistor between Pin 10 and Pin 5 (sensor cable)

¹⁾ Measured at sensor cable connector (consider the voltage drop as function of the sensor cable length).

Switching functions	
BCG450	→ Atmosphere switching function
BCG450-SD, -SP	2 (setpoints A and B)
Adjustment range	1×10 ⁻⁹ mbar ... 100 mbar
	Setpoints adjustable via potentiometers, one floating, normally open relay contact per setpoint (→ 20 , 42)
	(Adjusting the setpoints via field bus is described in the corresponding bus sections.)
Relay contact rating	≤60 VDC, ≤0.5 ADC
Atmosphere switching function	Atmospheric pressure threshold programmable via serial interfaces (→ 30)
BCG450	Atmospheric pressure threshold programmable via RS232
	Floating, normally open relay contact "atmosphere pressure reached" available at the sensor cable connector
Relay contact rating	≤30 VAC/DC, ≤0.3 AC/DC
BCG450-SD/SP	Atmospheric pressure threshold and relay function "atmosphere pressure reached" programmable via fieldbus interfaces (→ 1 or 2).
Relay contact rating	≤60 VDC, 0.5 ADC (same as SP A/B)

RS232C interface (BCG450)







Data rate	9600 Baud
Data format	binary 8 data bits one stop bit no parity bit no handshake
Connections (sensor cable connector)	
TxD (Transmit Data)	Pin 13
RxD (Receive Data)	Pin 14
Supply common (GND)	Pin 5

Function and communication protocol of the RS232C interface → [34](#)

DeviceNet interface (BCG450-SD)

Fieldbus name	DeviceNet
Standard applied	→ 6
Communication protocol, data format	→ 1 , 4
Interface, physical	CAN bus
Data rate (adjustable via "RATE" switch)	125 kBaud 250 kBaud 500 kBaud (default) "P" (125 kBaud, 250 kBaud, 500 kBaud programmable via DeviceNet (→ 1))
Node address (MAC ID) (Adjustable via "ADDRESS", "MSD", "LSD" switches)	0 ... 63 _{dec} (default = 63 _{dec}) "P" (0 ... 63 programmable via DeviceNet, → 1)
DeviceNet connector	Micro-Style, 5 pins, male
Cable	Shielded, special DeviceNet cable, 5 conductors (→ 21 and 4)
Cable length, system wiring	According to DeviceNet specifications (→ 6 , 4)

Profibus interface
(BCG450-SP)

Fieldbus name	Profibus
Standard applied	→  [7]
Communication protocol data format	→  [9], [7]
Interface, physical	RS485
Data rate	≤12 MBaud (→  [2])
Node address	
Local (Adjustable via hexadecimal "ADDRESS", "MSD", "LSD" switches)	00 ... 7D _{hex} (0 ... 125 _{dec})
Default setting	5C _{hex}
Via Profibus (hexadecimal "ADDRESS" switches set to >7d _{hex} (>125 _{dec}))	00 ... 7D _{hex} (0 ... 125 _{dec})
Profibus connection	D-Sub, 9 pins, female
Cable	Shielded, special Profibus cable (→  22 and  [5])
Cable length, system wiring	According to Profibus specifications (→  [7], [5])

Materials used

Materials exposed to vacuum	
Housing, supports, screens	stainless steel
Feedthroughs	NiFe, nickel plated
Insulator	glass
Cathode	iridium, yttrium oxide (Y ₂ O ₃)
Cathode holder	molybdenum
Pirani element	tungsten, copper
Sensor diaphragm	ceramic (Al ₂ O ₃)
Sensor contacts	SnAg
Internal volume	
DN 25 ISO-KF	≈24 cm ³
DN 40 CF-R	≈34 cm ³
Pressure max.	5 bar (absolute)

Ambiance

Admissible temperatures	
Storage	-20 ... 70 °C
Operation	0 ... 50 °C
Bakeout	+150 °C (at vacuum connection, without electronics unit, horizontally mounted)
Relative humidity (year's mean / during 60 days)	≤65 / 85% (no condensation)
Use	indoors only altitude up to 2000 m NN
Mounting orientation	any
Type of protection	IP 30

Dimensions [mm]

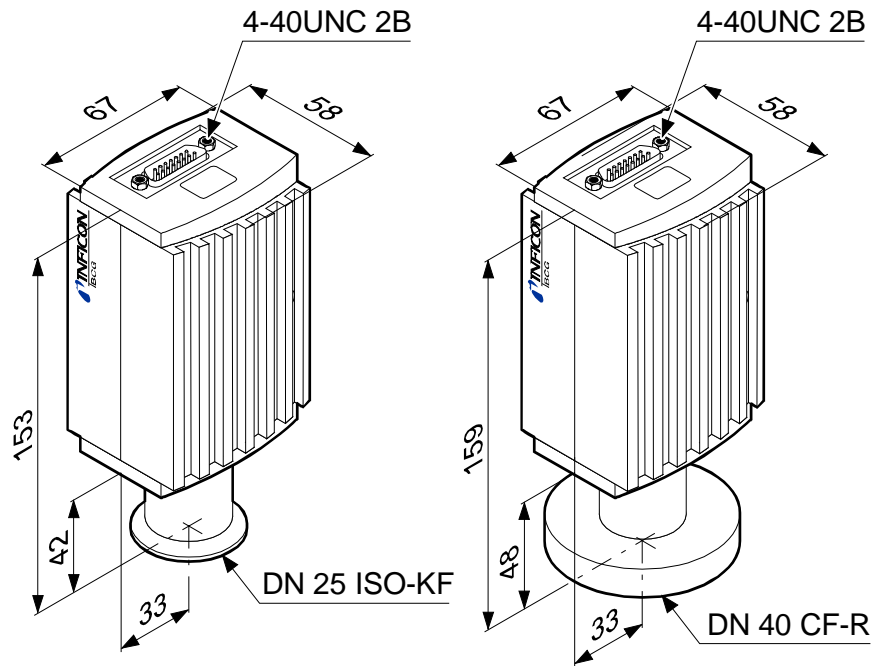

Gauges with DeviceNet connector are 14 mm longer.

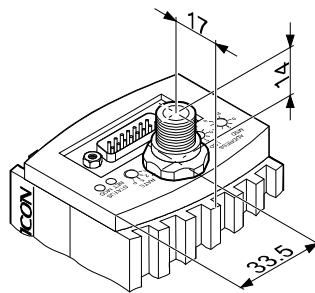

Weight

353-550, 353-552	≈305 g
353-551, 353-553	≈565 g
353-554, 353-557	≈445 g
353-556, 353-558	≈710 g

3 Installation

3.1 Vacuum Connection



DANGER

Caution: overpressure in the vacuum system >1 bar
 Injury caused by released parts and harm caused by escaping process gases can result if clamps are opened while the vacuum system is pressurized.
 Do not open any clamps while the vacuum system is pressurized. Use the type of clamps which are suited to overpressure.



DANGER

Caution: overpressure in the vacuum system >2 bar
 KF flange connections with elastomer seals (e.g. O-rings) cannot withstand such pressures. Process media can thus leak and possibly damage your health.
 Use O-rings provided with an outer centering ring.



DANGER

The gauge must be electrically connected to the grounded vacuum chamber. This connection must conform to the requirements of a protective connection according to EN 61010:

- CF connections fulfill this requirement
- For gauges with a KF vacuum connection, use a conductive metallic clamping ring.

Caution



Caution: vacuum component
 Dirt and damages impair the function of the vacuum component.
 When handling vacuum components, take appropriate measures to ensure cleanliness and prevent damages.

Caution



Caution: dirt sensitive area
 Touching the product or parts thereof with bare hands increases the desorption rate.
 Always wear clean, lint-free gloves and use clean tools when working in this area.



The gauge may be mounted in any orientation. To keep condensates and particles from getting into the measuring chamber, preferably choose a horizontal to upright position. See dimensional drawing for space requirements (→ [12](#)).

- The gauge is supplied with a built-in grid. For potentially contaminating applications and to protect the electrodes against light and fast charged particles, installation (→ [16](#)) of the optional baffle is recommended (→ [51](#)).
- The sensor can be baked at up to 80 °C (at vacuum connection, horizontally mounted). At temperatures exceeding 50 °C, the electronics unit has to be removed (→ [15](#)).

Procedure

- 1 Remove the protective lid.



The protective lid will be needed for maintenance.

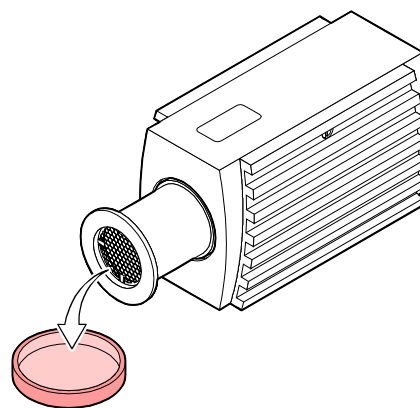

- 2 Make the flange connection to the vacuum system



INFICON recommends to install the gauge without applying vacuum grease.

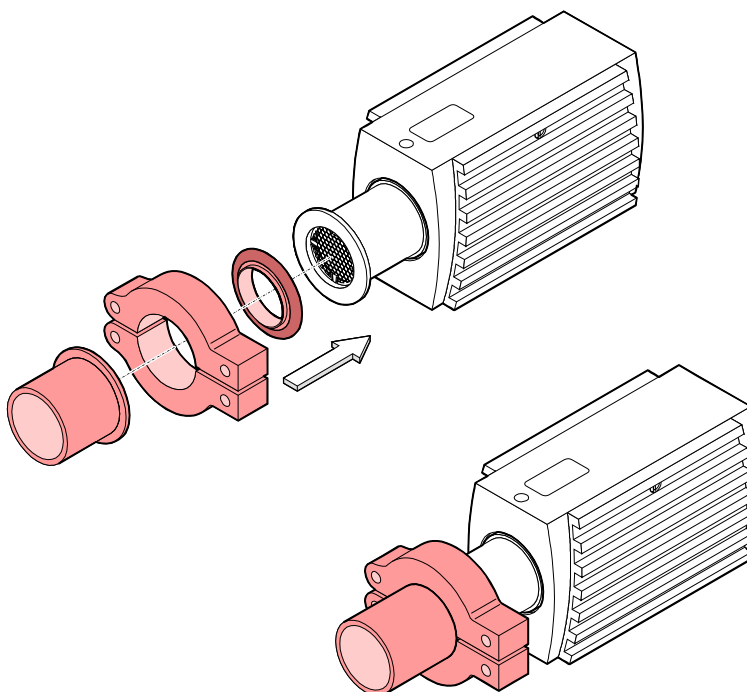

When installing the gauge, make sure that the area around the connector is accessible for the tools required for adjustment while the gauge is mounted (→ 42, 46).

When installing the gauge, allow for installing/deinstalling the connectors and accommodation of cable loops.

If you are using a gauge with display, make sure easy reading of the display is possible.

3.1.1 Removing and Installing the Electronics Unit

Required tools/material

- Allen key, size 2.5 mm

Removing the electronics unit

- 1 Unscrew the hexagon socket set screw (1) on the side of the electronics unit (2).

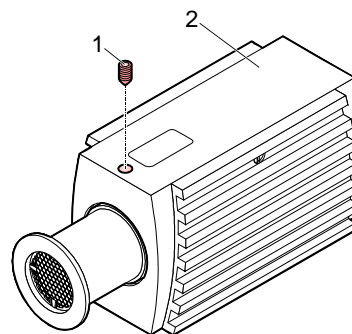

- 2 Remove the electronics unit **without twisting** it.

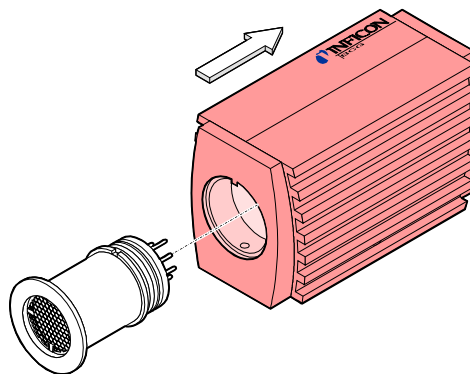

Installing the electronics unit

- 1 Place the electronics unit (2) on the sensor (3) (be careful to correctly align the pins and notch (4)).

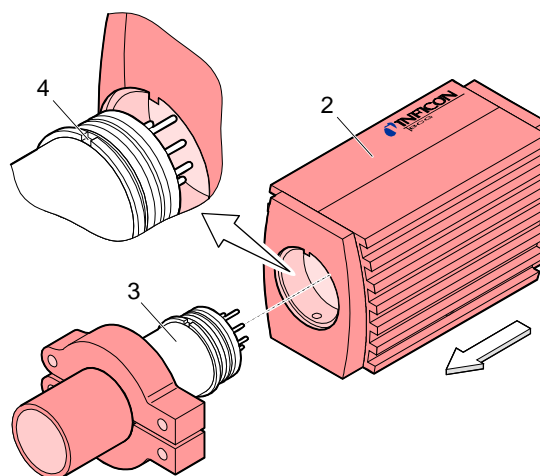

- 2 Slide the electronics unit in to the mechanical stop and lock it with the hexagon socket set screw.

3.1.2 Using the Optional Baffle

In severely contaminating processes and to protect measurement electrodes optically against light and fast charged particles, replacement of the built-in grid by the optional baffle (→ 51) is recommended.

Requirement

The gauge is deinstalled (deinstallation gauge → 44).

Required tools / material

- Baffle (→ 51)
- Pointed tweezers
- Pin (e.g. pencil)
- Screwdriver No 1

Installation

- 1** Carefully remove the grid with tweezers.

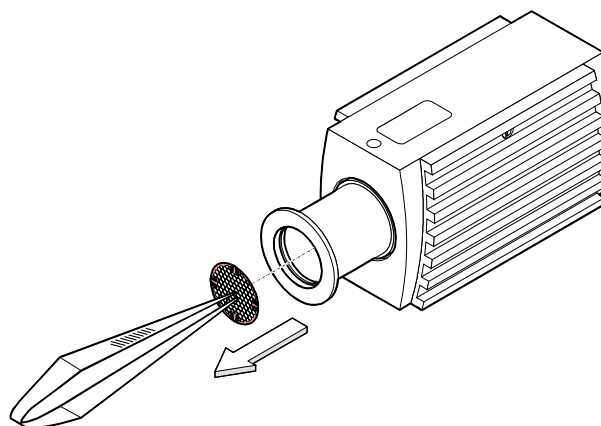

- 2** Carefully place the baffle onto the sensor opening.

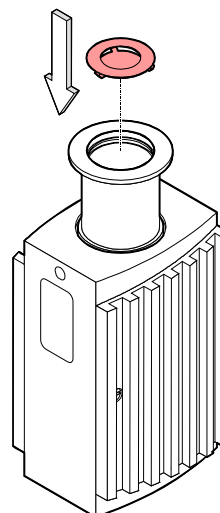

- 3** Using a pin, press the baffle down in the center until it catches.

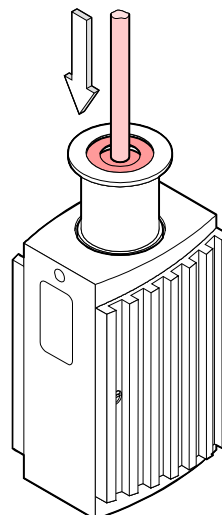

Deinstallation

Carefully remove the baffle with the screwdriver.

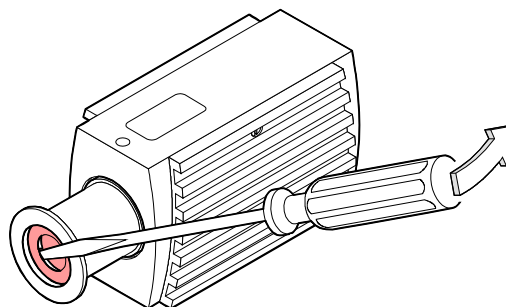

3.2 Electrical Connection

3.2.1 Use With INFICON VGC40x Vacuum Gauge Controller

If the gauge is used with an INFICON VGC40x controller, a corresponding sensor cable is required (→ [3]). The sensor cable permits supplying the gauge with power, transmitting measurement values and gauge statuses, and making parameter settings.



Caution



Caution: data transmission errors

The attempt to operate a fieldbus gauge (BPG450-SD / -SP) with the VGC40x Vacuum Gauge Controller (RS232C) causes data transmission errors.

Fieldbus gauges must not be operated with an INFICON VGC40x controller.

Required material

- Sensor cable (→ [3], INFICON sales literature)

Procedure

- 1 Plug the sensor connector into the gauge and secure it with the locking screws.
- 2 Connect the other end of the sensor cable to the INFICON controller and secure it.

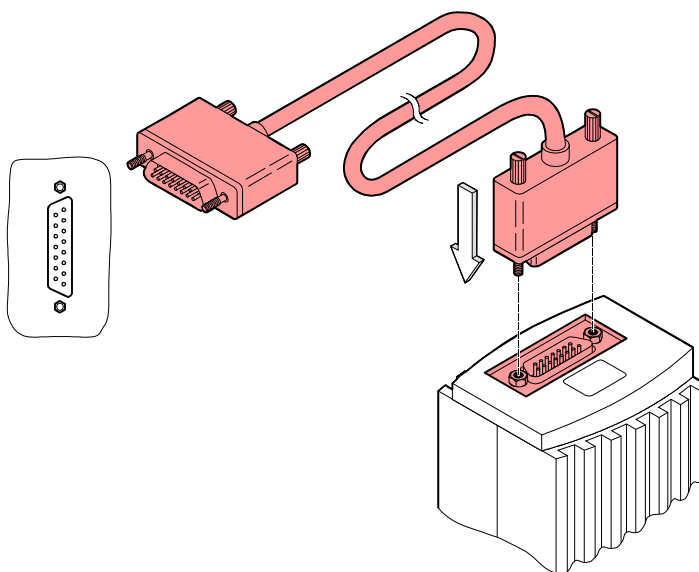

✓ The gauge can now be operated with the VGC40x controller.

3.2.2 Use With Other Controllers

The gauge can also be operated with other controllers. Especially the fieldbus versions BCG450-SD (DeviceNet) and BCG450-SP (Profibus) are usually operated as part of a network, controlled by a master or bus controller. In such cases, the control system has to be operated with the appropriate software and communication protocol.

3.2.2.1 Making an Individual Sensor Cable



For reasons of compatibility, the expression "sensor cable" is used for all BCG450 versions in this document, although the pressure reading of the gauges with fieldbus interface (BCG450-SD or BCG450-SP) is normally transmitted via DeviceNet or Profibus.

The sensor cable is required for supplying all BCG450 types with power. It also permits access to the relay contacts of the switching functions (→ 20).

Cable type

The application and length of the sensor cable have to be considered when determining the number and cross sections of the conductors (→ 9).

Procedure

- 1 Open the cable connector (D-Sub, 15 pins, female).
- 2 Prepare the cable and solder/crimp it to the connector as indicated in the diagram of the gauge used:

Sensor cable connection BCG450

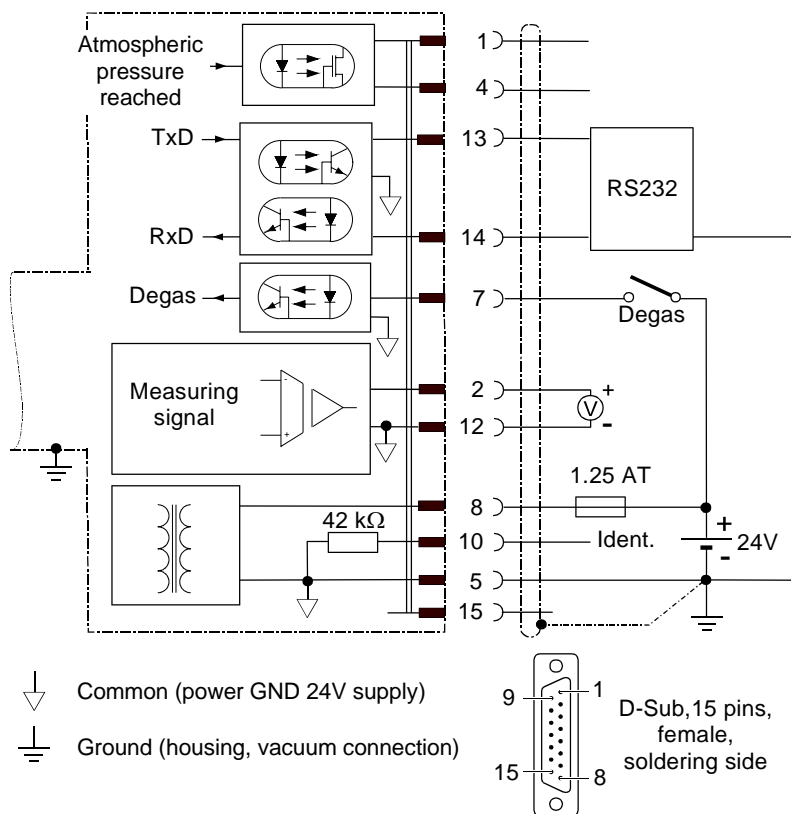

Electrical connection

Pin 1	Relay "Atmosphere reached", n.o. contact	
Pin 2	Measuring signal output	0 ... +10.13 V
Pin 4	Relay "Atmosphere reached", com contact	
Pin 5	Supply common	0 V
Pin 7	Degas on, active high	0 V/+24 V
Pin 8	Supply	+24 V
Pin 10	Gauge identification	
Pin 12	Measuring signal common	
Pin 13	RS232, TxD	
Pin 14	RS232, RxD	
Pin 15	Do not connect	

Pins 3, 6, 9 and 11 are not connected internally.

Sensor cable connection
BCG450-SD, -SP

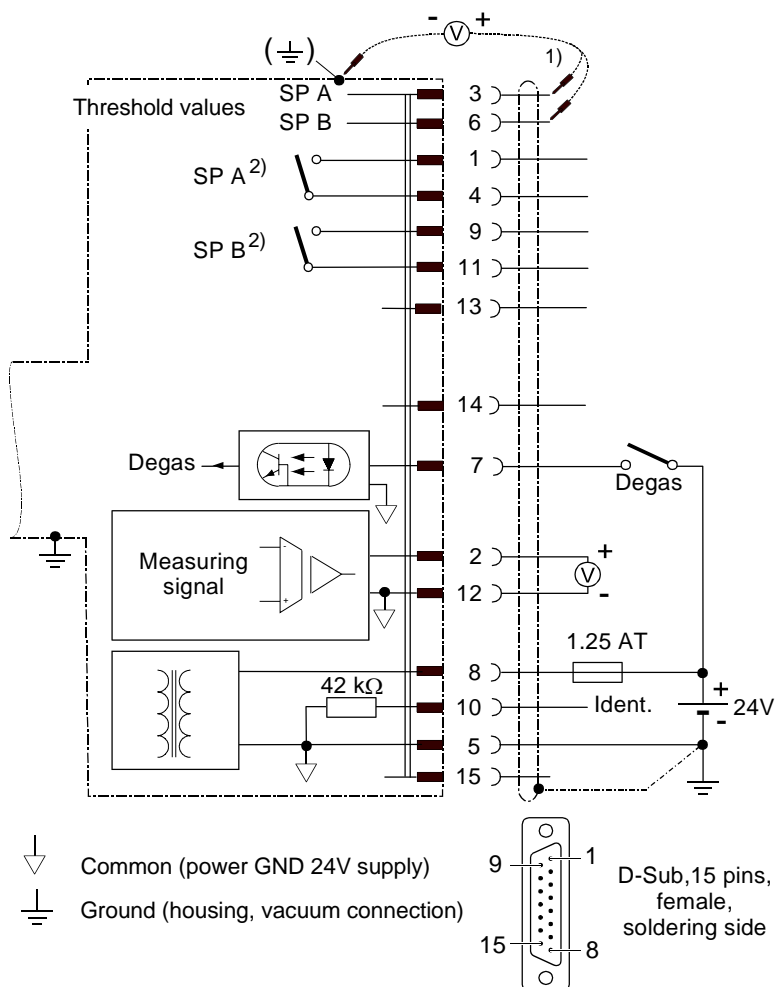

Electrical connection

Pin 1	Relay switching function A, n.o. contact	2)	
Pin 2	Measuring signal output		0 ... +10.13 V
Pin 3	Threshold (setpoint) A	1)	0 ... +10 V
Pin 4	Relay switching function A, com contact	2)	
Pin 5	Supply common		0 V
Pin 6	Threshold (setpoint) B	1)	0 ... +10 V
Pin 7	Degas on, active high		0 V/+24 V
Pin 8	Supply		+24 V
Pin 9	Relay switching function B, n.o. contact	2)	
Pin 10	Gauge identification		
Pin 11	Relay switching function B, com contact	2)	
Pin 12	Measuring signal common		
Pin 13	Do not connect		
Pin 14	Do not connect		
Pin 15	Do not connect		

1) Do not connect pin 3 and pin 6 for normal operation of the gauge. These pins are reserved for adjustment of the setpoint potentiometers (→ 43).

2) Relay assignment can be reprogrammed for atmosphere switching function via serial interfaces (→ 31 and [1] or [2]).

WARNING

Incorrect connection, incorrect polarity or inadmissible supply voltages can damage the gauge.



For cable lengths up to 5 m (0.34 mm² conductor cross-section) the output signal can be measured directly between the positive signal output (Pin 2) and supply common GND (Pin 5). At greater cable lengths, differential measurement between signal output (Pin 2) and signal common (Pin 12) is recommended.

- 3** Reassemble the cable connector.
- 4** On the other cable end, terminate the cable according to the requirements of the gauge controller you are using.
- 5** Plug the sensor connector into the gauge and secure it with the locking screws.

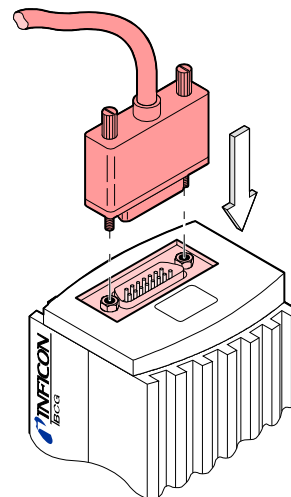

- 6** Connect the other end of the sensor cable to the connector of the instrument or gauge controller you are using.



The gauge can now be operated via analog and RS232C interface.

3.2.2.2 Making a DeviceNet Interface Cable (BCG450-SD)

For operating BCG450-SD via DeviceNet, an interface cable conforming to the DeviceNet standard is required. If no such cable is available, make one according to the following indications.

Cable type

A shielded special 5 conductor cable conforming to the DeviceNet standard has to be used (→ [4], [6]).

Procedure

- 1** Make the DeviceNet cable according to the following indications.

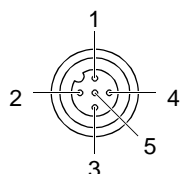

Micro-Style, 5 pins,
(DeviceNet)
female, soldering side

- Pin 1 Drain
- Pin 2 Supply +24 VDC (DeviceNet interface only)
- Pin 3 Supply common GND (DeviceNet interface only)
- Pin 4 CAN_H
- Pin 5 CAN_L

- 2 Plug the DeviceNet (and sensor) cable connector into the gauge.

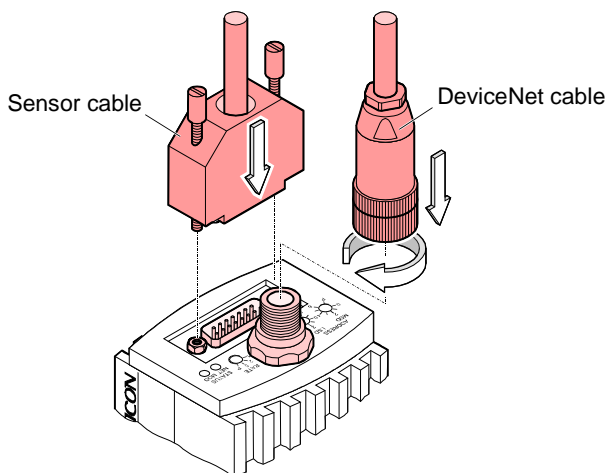

- 3 Lock the DeviceNet (and sensor) cable connector.

✓ The gauge can now be operated via DeviceNet interface (→ [39]).

3.2.2.3 Making a Profibus Interface Cable (BCG450-SP)

For operating BCG450-SP via Profibus, an interface cable conforming to the Profibus standard is required. If no such cable is available, make one according to the following indications.

Cable type

Only a cable that is suited to Profibus operation may be used (→ [5], [7]).

Procedure

- 1 Make the Profibus interface cable according to the following indications:

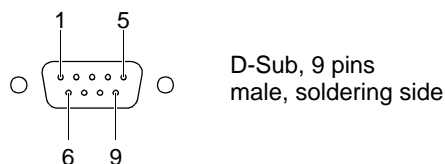

- Pin 1 Do not connect
- Pin 2 Do not connect
- Pin 3 RxD/TxD-P
- Pin 4 CNTR-P ¹⁾
- Pin 5 DGND ²⁾
- Pin 6 VP ²⁾
- Pin 7 Not connected internally
- Pin 8 RxD/TxD-N
- Pin 9 Not connected internally

¹⁾ Only to be connected if an *optical link* module is used.

²⁾ Only required as line termination for devices at both ends of bus cable (→ [5]).

- 2** Plug the Profibus (and sensor) cable connector into the gauge.

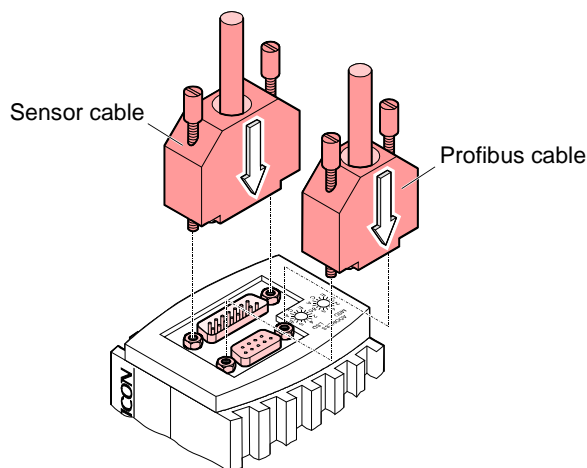

- 3** Lock the Profibus (and sensor) cable connector.

✓ The gauge can now be operated via Profibus interface (→ 41).

3.2.3 Using the Optional Power Supply (With RS232C Line)

Technical data

The optional 24 V power supply (→ 51) allows RS232C operation of the BCG450 gauge with any suitable instrument or control device.

The instrument or control device needs to be equipped with a software that supports the RS232C protocol of the gauge (→ 34).

Mains connection

Mains voltage	90 ... 250 VAC 50 ... 60 Hz
Mains cable	1.8 meter (Schuko DIN and U.S. connectors)

Output (operating voltage of gauge, V_s)

Voltage	21 ... 27 VDC, set to 24 VDC
Current	Max. 1.5 A

Gauge connection

Connector	D-Sub, 15 pins, female
24 VDC cable	5 m, black

Connection of the instrument or control device

RS232C connection	D-Sub, 9 pins, female
Cable	5 m, black, 3 conductors, shielded

Wiring diagram

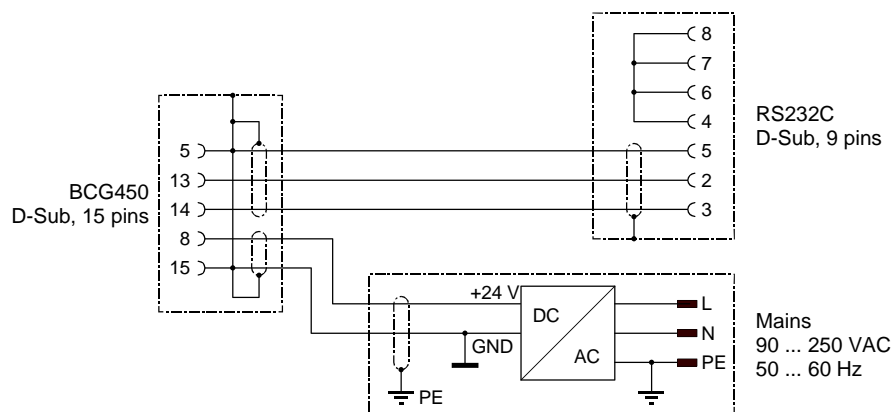

Connecting the power supply

- 1** Connect the power supply to the the gauge and lock the connector with the screws.
- 2** Connect the RS232C line to the instrument or control device and lock the connector with the screws.

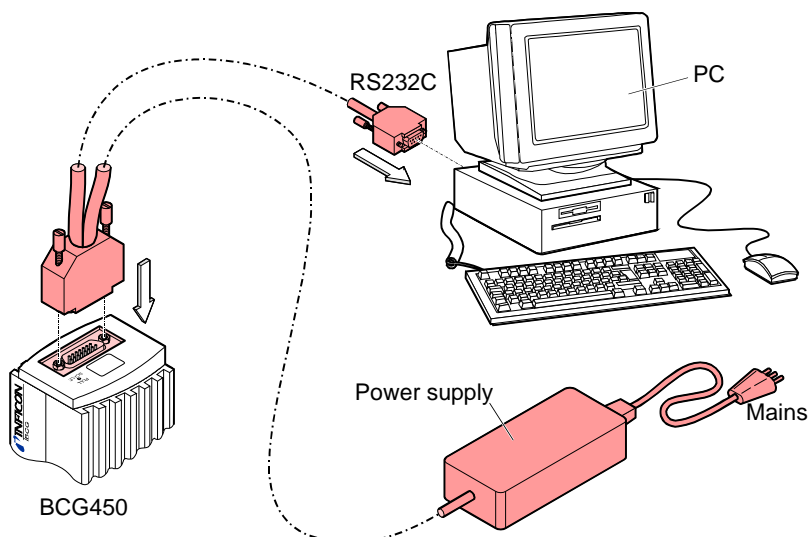

- 3** Connect the power supply to the mains.
- ✓ The gauge can now be operated via RS232C interface (→ [34](#)).

4 Operation

4.1 Measuring Principle, Measuring Behavior

Bayard-Alpert (BA)

The BCG450 vacuum gauges consist of three separate measuring systems (hot cathode Bayard-Alpert (BA) Pirani sensor and capacitance diaphragm sensor).

The BA measuring system uses an electrode system according to Bayard-Alpert which is designed for a low x-ray limit.

The measuring principle of this measuring system is based on gas ionization. Electrons emitted by the hot cathode (F) ionize a number of molecules proportional to the pressure in the measuring chamber. The ion collector (IC) collects the thus generated ion current I^+ and feeds it to the electrometer amplifier of the measurement instrument. The ion current is dependent upon the emission current I_e , the gas type, and the gas pressure p according to the following relationship:

$$I^+ = I_e \times p \times C$$

Factor C represents the sensitivity of the gauge head. It is generally specified for N_2 .

The lower measurement limit is 5×10^{-10} mbar (gauge metal sealed).

To usefully cover the whole range of 5×10^{-10} mbar ... 10^{-2} mbar, a low emission current is used in the high pressure range (fine vacuum) and a high emission current is used in the low pressure range (high vacuum). The switching of the emission current takes place at decreasing pressure at approx. 7.2×10^{-6} mbar, at increasing pressure at approx. 3.2×10^{-5} mbar. At the switching threshold, the BCG450 can temporarily (<2 s) deviate from the specified accuracy.

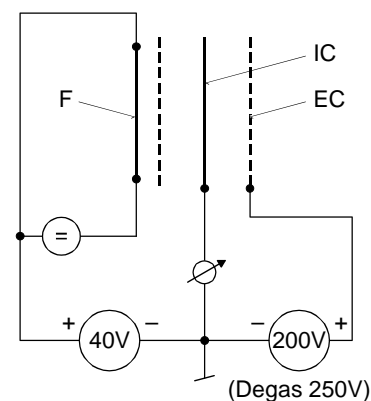
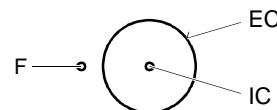

Diagram of the BA measuring system

- F hot cathode (filament)
- IC ion collector
- EC anode (electron collector)



Pirani

Within certain limits, the thermal conductivity of gases is pressure dependent. This physical phenomenon is used for pressure measurement in the thermal conductance vacuum meter according to Pirani. A self-adjusting bridge is used as measuring circuit (→ schematic). A thin tungsten wire forms the sensor element. Wire resistance and thus temperature are kept constant through a suitable control circuit. The electric power supplied to the wire is a measure for the thermal conductance and thus the gas pressure. The basic principle of the self-adjusting bridge circuit is shown in the following schematic.

Schematic

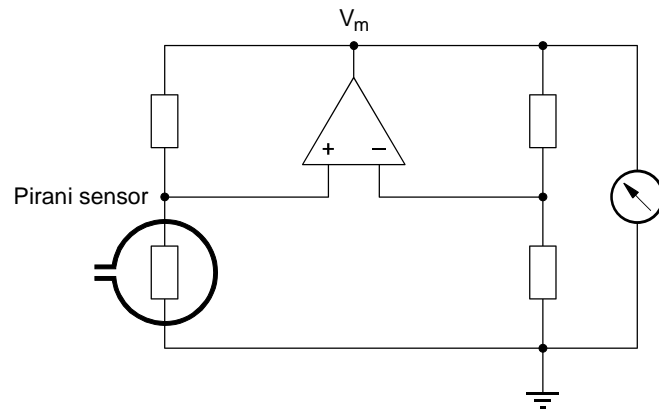

The bridge voltage V_m is a measure for the gas pressure and is further processed electronically (linearization, conversion).

Capacitance diaphragm sensor

A capacitance diaphragm sensor consists of a reference vacuum chamber, separated from the measured gas pressure by a diaphragm. The capacitance of a pair of electrodes attached to the diaphragm and the chamber is measured electronically. A pressure difference acting upon the diaphragm will deflect it and cause a change of capacitance between the electrodes. A pressure related measuring signal is produced, ready for further processing.

Schematic

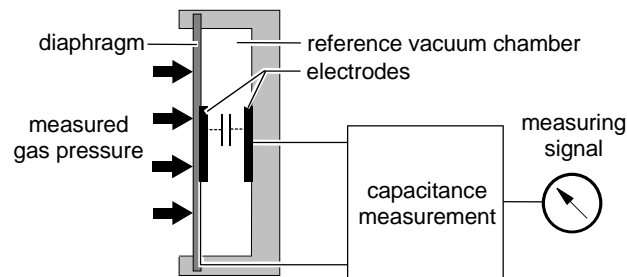

Measuring range

The BCG450 gauges continuously cover the measuring range 5×10^{-10} mbar ... 1500 mbar.

- The Pirani constantly monitors the pressure.
- The hot cathode (controlled by the Pirani) is activated only at pressures $< 2.4 \times 10^{-2}$ mbar.

If the measured pressure is higher than the switching threshold, the hot cathode is switched off and the Pirani measurement value is output.

If the Pirani measurement drops below the switching threshold ($p = 2.4 \times 10^{-2}$ mbar), the hot cathode is switched on. After heating up, the measured value of the hot cathode is fed to the output. In the crossover range of 5.5×10^{-3} ... 2.0×10^{-2} mbar, the output signal is generated from both measurements.

Pressure rising over the switching threshold ($p = 3.2 \times 10^{-2}$ mbar) causes the hot cathode to be switched off. The Pirani measurement value is output.

- Above 10 mbar (up to 1500 mbar) the measurement signal of the capacitance diaphragm sensor is used.

In the crossover range 1 ... 10 mbar a mixture of the Pirani sensor signal and the capacitance diaphragm sensor signal is processed.

Gas type dependence

Due to the capacitance diaphragm sensor used in the upper pressure range, a minimized gas type dependence is achieved.

Pressure range	Measuring principle	Gas type dependence
10 ... 1500 mbar	capacitance diaphragm sensor	independent of gas type, no correction required
1 ... 10 mbar	capacitance diaphragm sensor and Pirani sensor	crossover range
2×10^{-2} ... 1 mbar	Pirani sensor	¹⁾
5×10^{-3} ... 2×10^{-2} mbar	Pirani sensor and hot cathode ionisation sensor (BA)	crossover range
5×10^{-10} ... 5×10^{-3} mbar	hot cathode ionisation sensor (BA)	¹⁾

¹⁾ Pressure indicated applies to dry air, O₂, CO and N₂ and has to be converted for other gases (→ Appendix B).

4.2 Operational Principle of the Gauge

The analog measuring signals of the BA and Pirani sensors are converted into a digital form by a micro-controller and subsequently converted to a value representing the measured total pressure. After further processing this value is available as an analog measurement signal (0 ... +10.13 V) at the output (sensor cable connector Pin 2 and Pin 12). The maximum output signal is internally limited to +10.13 V (1500 mbar). The measured value can be read as digital value through the RS232C interface (only BCG450) (Pins 13, 14 and 5) (→ 34). Gauges with a display show the value as pressure. The default setting of the displayed pressure unit is mbar. It can be modified via the RS232C interface (only BCG450) (→ 34).

In addition to converting the output signal, the micro controller's functions include monitoring of the emission, calculation of the total pressure based on the measurements of the three sensors, and communication via RS232C interface (only BCG450).

With the built-in atmosphere switching function an atmospheric pressure threshold can be programmed. If the pressure rises above this value a (semi conductor) relay "atmospheric pressure reached" is activated. The threshold can be programmed by the user as a percentage of the actual atmospheric pressure (ambient).

Field Bus Versions (BCG450-SD, BCG450-SP)

These gauges can be used in a network together with other equipment meeting the respective standards. Technical data, interface and communication is described in separate sections (→ 39 for DeviceNet and 41 for Profibus).

Two adjustable switching functions are integrated in the gauge. The corresponding relay contacts are available at the sensor cable connector (→ 8, 20, 42).

The basic sensor and sensor electronics of all BCG450 versions are identical.

4.3 Putting the Gauge Into Operation

When the operating voltage is supplied (→ Technical Data), the output signal is available between Pin 2 (+) and Pin 12 (-) of the sensor cable connector (Relationship Output Signal – Pressure → Appendix A).

Allow for a stabilizing time of approx. 10 min. Once the gauge has been switched on, permanently leave it on irrespective of the pressure.

Communication via the digital interfaces is described in separate sections of this document.

4.4 Degas

Contamination

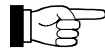

Gauge failures due to contamination are not covered by the warranty.

Deposits on the electrode system of the BA sensor can lead to unstable measurement readings.

The degas process allows in-situ cleaning of the electrode system by heating the electron collector grid to approx. 700 °C by electron bombardment.

Depending on the application, this function can be activated by the system control via one of the gauges digital interfaces. The BCG450 automatically terminates the degas process after 3 minutes, if it has not been stopped before.



The degas process should be run at pressures below 7.2×10^{-6} mbar (emission current 5 mA).

For a repeated degas process, the control signal first has to change from On (+24 V) to Off (0 V), to then start degas again with a new On (+24 V) command. It is recommended that the degas signal be set to Off again by the system control after 3 minutes of degassing, to achieve an unambiguous operating status.



A new degas cycle can only be started after a waiting time of 30 minutes.

4.5 Emission Control Mode

General

The emission control mode function defines the rules by which the emission of the gauge is switched on and off.

The manual mode feature has a positive effect on gauge live time, mainly in process situations where the process chamber has to be vented frequently.

Emission Control Mode	Description
<ul style="list-style-type: none"> Automatic (AUTO) 	<p>By default, the automatic mode is active and the emission is switched on and off automatically by the gauge. However, the emission will only be switched on if the pressure falls below "Switching on pressure" (→ 8). If the pressure rises above the "Switching off pressure" (→ 8) the emission is switched off. However, the user can switch off the emission any time via the interfaces (→ below).</p> <p>If the emission is switched off manually while it is in the on state, it is switched on again only after pressure has exceeded "Switching off pressure" and subsequently fallen below "Switching on pressure".</p>
<ul style="list-style-type: none"> Manual (MAN) 	<p>In manual mode, the emission can be switched on and off by the user. However, switching on the emission is only possible if the pressure is below "Switching on pressure" (→ 8). If the pressure rises above the "Switching off pressure" (→ 8) while the emission is on, the emission will be switched off by the gauge.</p>



The emission control mode parameter is only accessible via the serial interfaces and described in the respective sections (→ 34, [1] and [2]).

(Switching the emission on/off via RS232 → 38)

4.6 Atmosphere Switching Function

4.6.1 Functional Principle

The Atmosphere Switching Function is used to define an atmospheric pressure threshold where a (semiconductor) relay "Atmospheric pressure reached" is activated or deactivated ¹⁾.

The atmospheric pressure threshold is user programmable as a percentage of the ambient atmospheric pressure (100%) ²⁾.

A separate sensor built into the gauge (measuring ambient atmospheric pressure) is used as a reference.

The following rule applies:

$$\text{Atmospheric pressure threshold} = \frac{\text{Atmospheric pressure} \times N}{100}$$

where:

Atmospheric pressure threshold [mbar] : If chamber pressure rises above this value, the "Atmospheric pressure reached" relay is activated ³⁾

Atmospheric pressure [mbar] : Ambient atmospheric pressure (100%) (measured outside the vacuum chamber)

N [%] : User programmable percentage value (admissible range: 1 ... 140% ²⁾, default = 99%)



The measuring range of the gauge is limited to 1500 mbar. If the calculated atmospheric pressure threshold exceeds 1500 mbar, the relay will never be activated. Keep this in mind when choosing N.



It is possible to calibrate the atmospheric pressure sensor (→ 46).

¹⁾ Depending on gauge version, access to "Atmospheric pressure reached" relay contacts differ:

BCG450: A hard wired (semiconductor) relay contact is available between pins 1 and 4 at the sensor cable connector (→ 19 and 32).

BCG450-SD/SP: The function of the setpoint relays SP A/B (→ 20) can be reprogrammed to perform as "Atmospheric pressure reached" relays. Reprogramming is carried out via fieldbus. (further informationen → [1] or [2]).

(Default setting: relays are assigned to (SP A / B) setpoints)

²⁾ Programming of the percentage N can only be carried out via the serial interfaces (RS232, DeviceNet or Profibus, → 34, [1] or [2]).

³⁾ A fixed hysteresis of 2% of the atmospheric pressure threshold is programmed (→ example below).

Example

The following diagram shows the functional principle using example values (*italic = example values*):

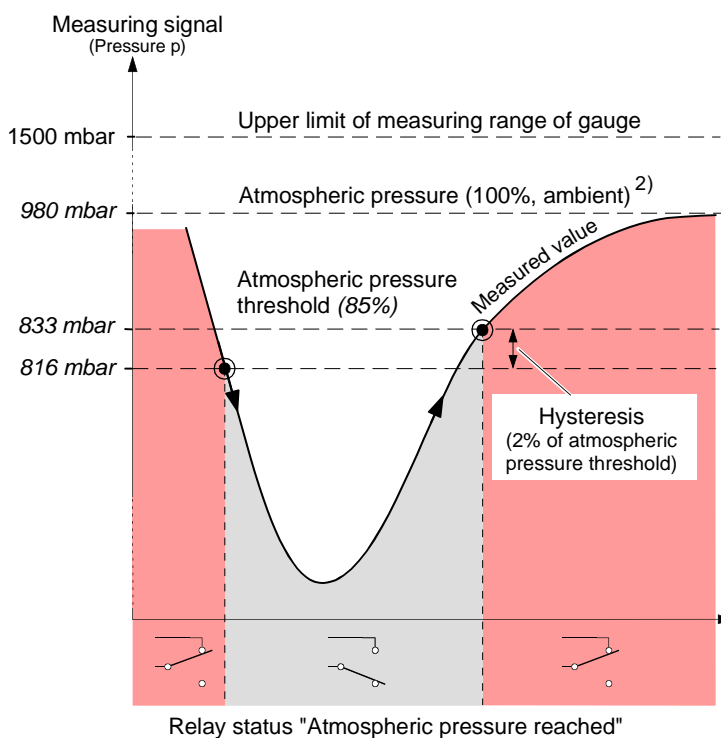

4.6.2 Programming the Atmospheric Pressure Threshold

Programming via RS232

Programming the atmospheric pressure threshold can only be carried out via the serial interfaces.

The relevant parameter: percentage of atmospheric pressure (N) is sent to the gauge in a 5 byte long command string (general information on RS232 interface → 34):

Byte No.	Function	Value	Comment
0	Length of data string	0x03 hex	set value
1	Data	0x11 hex	
2	Data	0x10 hex	
3	Data	0x01 ... 0x8C hex	¹⁾
4	Check sum (of bytes No. 1 ... 3)	0x00 ... 0xFF hex	low byte of sum, high byte is ignored

¹⁾ Admissible range of percentage value (N):

0x01_{hex} ... 0x8C_{hex} $\hat{=}$ 1_{dec} ... 140_{dec} $\hat{=}$ 1% ... 140% (default = 99%).

Example:

Atmospheric pressure = 1000 mbar (example) ²⁾

N = 99% (default)

Hysteresis = 2% (fixed)

⇒ Atmospheric pressure threshold = 990 mbar

⇒ If the pressure exceeds 990 mbar, the relay "Atmosphere reached". is activated. As the pressure drops below 970 mbar, the relays is deactivated.

²⁾ It is possible to calibrate the atmospheric pressure sensor (→ 46).

Programming via fieldbus interfaces

The definition of the function assigned to the relays (SP A/B or "Atmospheric pressure reached") and the value "Percentage of atmospheric pressure" (N) is described in the communication protocol of the respective interface version (for DeviceNet → [1], for Profibus → [2]).

4.6.3 Wiring the relay "Atmospheric Pressure Reached" (BCG450)

The signal: atmospheric pressure reached is made available via a floating n. o. contact of a photo MOS relay contact at the sensor cable connector (→ 19) ¹⁾.

Specifications of the n. o. contact:

Load voltage (V_L)	≤ 30 V AC/DC
Load current	≤ 300 mA AC/DC ²⁾

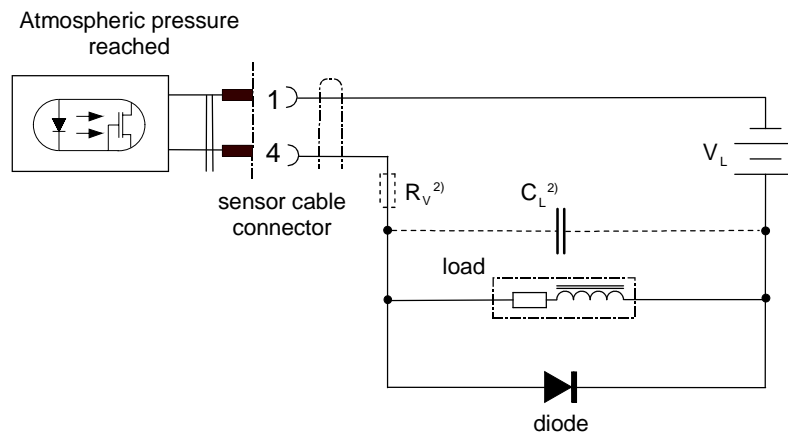

- 1) Contact specifications for fieldbus gauges BPG450-SD / -SP can be found in the section: Technical Data since the (reprogrammed) setpoint relays (SP A/B) are used (→ 20, [1] or [2]).
- 2) In case of capacitive loads, the charging current has to be limited to the max. current value specified above (e.g. using a current limiting resistor R_V). For inductive loads, voltage peaks have to be suppressed by a parallel diode as shown. To minimize inductance, keep the wiring as short as possible.

4.7 Display (BCG450)

The gauges with part number

353-552 and
353-553

have a built-in two-line display with an LCD matrix of 32x16 pixels. The first line shows the pressure, the second line the pressure unit, the function and possible errors. The background illumination is usually green, in the event of an error, it changes to red. The pressure is displayed in mbar (default), Torr or Pa. The pressure unit can be changed via RS232C interface (→ [34](#)).

Pressure Display

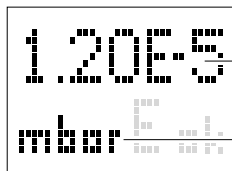

Pressure reading

Pressure unit

Function Display

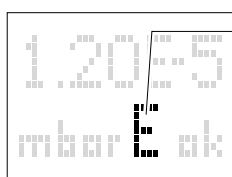

Function display

(none) Pirani operation

E Emission 25 μ A

E. Emission 5 mA

I Degas

Error Display



No error
(green background illumination)

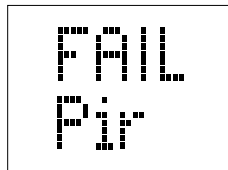

Pirani sensor error
(red background illumination)

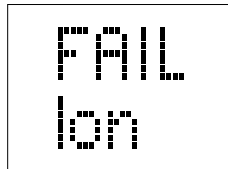

BA sensor error
(red background illumination)

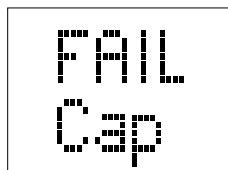

Diaphragm sensor error
(red background illumination)

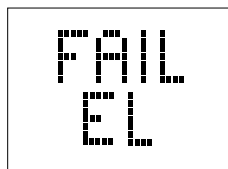

EEPROM error
(red background illumination)

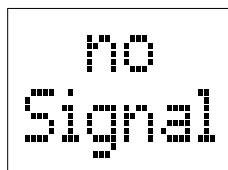

Internal data connection failure
(red background illumination)



What to do in case of problems → 48.

4.8 RS232C Interface

The built-in RS232C interface allows transmission of digital measurement data and instrument conditions as well as the setting of instrument parameters.

Caution

Caution: data transmission errors
The attempt to operate a fieldbus gauge (BPG450-SD / -SP) with the RS232C interface causes data transmission errors.
Fieldbus gauges must not be operated with the RS232C interface.

4.8.1 Description of the Functions

The interface works in duplex mode. A nine byte string is sent continuously without a request approx. every 20 ms.

Commands are transmitted to the gauge in a five byte input (receive) string.

Operational parameters

- Data rate 9600 Baud set value, no handshake
- Byte 8 data bits
 1 stop bit

Electrical connections

- TxD Pin 13
- RxD Pin 14
- GND Pin 5
(Sensor cable connector)

4.8.1.1 Output String (Transmit)

The complete output string (frame) is nine bytes (byte 0 ... 8). The data string is seven bytes (byte 1 ... 7).

Format of the output string

Byte No.	Function	Value	Comment
0	Length of data string	7	set value
1	Page number	5	for BCG450
2	Status		→ Status byte
3	Error		→ Error byte
4	Measurement high byte	0 ... 255	→ Calculation of pressure value
5	Measurement low byte	0 ... 255	→ Calculation of pressure value
6	Software version	0 ... 255	→ Software version
7	Response value	13	for BCG450
8	Check sum	0 ... 255	→ Synchronization

Synchronization

Synchronization of the master is achieved by testing three bytes:

Byte No.	Function	Value	Comment
0	Length of data string	7	set value
1	Page number	5	for BCG450
8	Check sum of bytes 1 ... 7	0 ... 255	Low byte of check sum ¹⁾

¹⁾ High order bytes are ignored in the check sum.

Status byte

Bit 1	Bit 0	Definition
0	0	emission off
0	1	emission 25 μ A
1	0	emission 5 mA
1	1	degas
Bit 2		Definition
x		reserved for future use
x		reserved for future use
Bit 3		Definition
0 \leftrightarrow 1		toggle bit, changes with every string received correctly
Bit 5	Bit 4	Definition
0	0	current pressure unit mbar
0	1	current pressure unit Torr
1	0	current pressure unit Pa
Bit 7	Bit 6	Definition
x	x	reserved for future use

Error byte

Bit No.	Definition	Message on display (only BCG450 353-552 and 353-553)
0	diaphragm sensor error	"FAIL Cap"
1	reserved for future use	—
2	Pirani sensor error	"FAIL Pir"
3	reserved for future use	—
4	BA sensor error	"FAIL Ion"
5	reserved for future use	—
6	hardware failure, EEPROM failure	"FAIL EL"
7	reserved for future use	—

Software version

The software version of the gauge can be calculated from the response value of byte 6 of the transmitted string according to the following rule:

$$\text{Version No} = \text{Value}_{\text{Byte 6}} / 20$$

(Example: According to the above formula, $\text{Value}_{\text{Byte 6}}$ of 32 means software version 1.6)

Calculation of the pressure value

The pressure can be calculated from bytes 4 and 5 of the transmitted string. Depending on the currently selected pressure unit (\rightarrow byte 2, bits 4 and 5), the appropriate rule must be applied.

As result, the pressure value results in the usual decimal format.

$$p_{\text{mbar}} = 10^{((\text{high byte} \times 256 + \text{low byte}) / 4000 - 12.5)}$$

$$p_{\text{Torr}} = 10^{((\text{high byte} \times 256 + \text{low byte}) / 4000 - 12.625)}$$

$$p_{\text{Pa}} = 10^{((\text{high byte} \times 256 + \text{low byte}) / 4000 - 10.5)}$$

Example

The example is based on the following output string:

Byte No.	0	1	2	3	4	5	6	7	8
Value	7	5	0	0	242	48	20	13	69

The instrument or controller (receiver) interprets this string as follows:

Byte No.	Function	Value	Comment
0	Length of data string	7	set value
1	Page number	5	BCG450
2	Status	0	Emission = off Pressure unit = mbar
3	Error	0	No error
4	Measurement		
4	High byte	242	Calculation of the pressure: $p = 10^{((242 \times 256 + 48) / 4000 - 12.5)} = 1000 \text{ mbar}$
5	Low byte	48	
6	Software version	20	Software version = 20 / 20 = 1.0
7	Sensor type	13	BCG450
8	Check sum	69	$5 + 0 + 0 + 242 + 48 + 20 + 13 = 328_{\text{dec}} \hat{=} 0148_{\text{hex}}$ High order byte is ignored \Rightarrow Check sum = $48_{\text{hex}} \hat{=} 72_{\text{dec}}$

4.8.1.2 Input String (Receive)

For transmission of the commands to the gauge, a string (frame) of five bytes is sent (without <CR>). Byte 1 to byte 3 form the data string.

Format of the input string

Byte No	Function	Value	Comment
0	Length of data string	3	set value
1	Data		→ admissible input strings
2	Data		→ admissible input strings
3	Data		→ admissible input strings
4	Check sum (of bytes No 1 ... 3)	0 ... 255	(low byte of sum) ¹⁾

¹⁾ High order bytes are ignored in the check sum.

Admissible input strings

For commands to the gauge, six defined strings are used:

Command:	Byte No.				
	0	1	2	3	4 ²⁾
Set the unit mbar on the display ¹⁾	3	0x10	0x8E	0	0x9E
Set the unit Torr on the display ¹⁾	3	0x10	0x8E	1	0x9F
Set the unit Pa on the display ¹⁾	3	0x10	0x8E	2	0xA0
Storage of current unit ³⁾	3	0x20	0x07	-	0x27
Switch degas on (switches itself off after 3 min.)	3	0x10	0xC4	1	0xD5
Switch degas off (before 3 min.)	3	0x10	0xC4	0	0xD4
Read software version ⁴⁾	3	0x00	0xD1	-	0xD1
Reset	3	0x40	0	0	0x40
Switch emission on ⁵⁾	3	0x40	0x10	1	0x51
Switch emission off ⁵⁾	3	0x40	0x10	0	0x50
Emission Control Mode automatic (AUTO) ⁶⁾	3	0x10	0x8A	1	0x8B
Emission Control Mode manual (MAN) ⁶⁾	3	0x10	0x8A	0	0x8A

¹⁾ Only required for gauges with display (353-552 and 353-553). Transmitted data is not affected by this setting.

²⁾ Only low order byte of sum (high order byte is ignored).

³⁾ Current unit is stored in power-failure-safe NV RAM.

⁴⁾ Response value in byte no. 6 of transmitted string.

⁵⁾ On/off switching requirements →  29.

⁶⁾ Defines the Emission Control Mode (→  29)
 AUTO = emission on/off automatically controlled by the gauge
 MAN = emission on/off controlled via interfaces

4.9 DeviceNet Interface (BCG450-SD)

This interface allows operation of BCG450-SD with part number 353-557 and 353-558

in connection with other devices that are suited for DeviceNet operation. The physical interface and communication firmware of BCG450-SD comply with the DeviceNet standard (→ [4], [6]).

Two adjustable switching functions are integrated in BCG450-SD. The corresponding relay contacts are available at the sensor cable connector (→ 8, 20, 42).

The basic sensor and sensor electronics of all BCG450 gauges are identical.

Caution

Caution: data transmission errors
 The attempt to operate the BPG450-SD with the RS232C interface causes data transmission errors.
 The BCG450-SD must not be operated with the RS232C interface.

4.9.1 Description of the Functions

Via this interface, the following and further data are exchanged in the standardized DeviceNet protocol (→ [1]):

- Pressure reading
- Pressure unit (Torr, mbar, Pa)
- Degas function
- Status and error messages
- Status of the switching functions

4.9.2 Operating Parameters

As the DeviceNet protocol is highly complex, the parameters and programming of BCG450-SD are described in detail in the separate Communication Protocol (→ [1]).

4.9.2.1 Operating Software

Before the gauge is put into operation, it has to be configured for DeviceNet operation. A configuration tool and the device specific EDS file (Electronic Data Sheet) are required for this purpose. The EDS file can be downloaded via internet (→ [3]).

4.9.2.2 Node Address Setting

For unambiguous identification of the gauge in a DeviceNet environment, a node address is required. The node address setting is made on the gauge or programmed via DeviceNet.

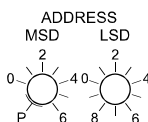

Set the node address (0 ... 63_{dec}) via the "ADDRESS" "MSD" and "LSD" switches. The node address is polled by the firmware when the gauge is switched on. If the setting deviates from the stored value, the new value is taken over into the NVRAM. If a setting higher than 63 is made, the previous node address setting remains valid.

Default address setting is 63_{dec}.

If the „MSD“ switch is in the "P" position, the node address is programmable via DeviceNet (→ [1]).

4.9.2.3 Data Rate Setting

The admissible data rate depends on a number of factors such as system parameters and cable length →  [4], [6]). It can be set on the gauge or programmed via DeviceNet.



By means of the "RATE" switch, the data rate can be set to 125 ("1"), 250 ("2") or 500 kBaud ("5").

If the switch is in any of the "P" positions, the data rate is programmable via DeviceNet (→  [1]).

4.9.3 Status Lights

Two lights (LEDs) on the gauge inform on the gauge status and the current DeviceNet status.



"STATUS MOD"
(gauge status):

Light status	Description
Dark	No supply
Flashing red/green	Selftest
Green	Normal operation
Red	Non recoverable error
Flashing red	Recoverable error (e.g. missing DeviceNet power supply)

"STATUS NET"
(network status):

Light status	Description
Dark	Gauge not online: <ul style="list-style-type: none"> – Selftest not yet concluded – No supply, → "STATUS MOD" light
Flashing green	Gauge online but no communication: <ul style="list-style-type: none"> – Selftest concluded but no communication to other nodes established – Gauge not assigned to any master
Green	Gauge online; necessary connections established
Flashing red	One or several input/output connections in "time out" status
Red	Communication error. The gauge has detected an error that impedes communication via the network (e.g. two identical node addresses (MAC IC) or "Bus-off")

Electrical connections

The gauge is connected to the DeviceNet system via the 5-pin DeviceNet connector (→  21).

4.10 Profibus Interface (BCG450-SP)

This interface allows operation of BCG450-SP with part number 353-554 and 353-556

in connection with other devices that are suited for Profibus operation. The physical interface and communication firmware of BCG450-SP comply with the Profibus standard (→ [7], [5]).

Two adjustable switching functions are integrated in the BCG450-SP. The corresponding relay contacts are available at the sensor cable connector (→ 8, 20, 42).

The basic sensor and sensor electronics of all BCG450 gauges are identical.

Caution

Caution: data transmission errors
 The attempt to operate the BPG450-SP with the RS232C interface causes data transmission errors.
 The BCG450-SP must not be operated with the RS232C interface..

4.10.1 Description of the Functions

Via this interface, the following and further data are exchanged in the standardized Profibus protocol (→ [2]):

- Pressure reading
- Pressure unit (Torr, mbar, Pa)
- Degas function
- Status and error messages
- Status of the switching functions

4.10.2 Operating Parameters

As the DeviceNet protocol is highly complex, the parameters and programming of BCG450-SP are described in detail in the separate Communication Protocol (→ [2]).

4.10.2.1 Operating Software

For operating the gauge via Profibus, prior installation of the BCG450 specific GSD file is required on the bus master side. This file can be downloaded via internet (→ [3]).

4.10.2.2 Node Address Setting

For unambiguous identification of the gauge in a Profibus environment, a node address is required. The node address setting is made on the gauge.

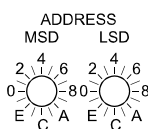

The node address (0 ... 125_{dec}) is set in hexadecimal form (00 ... 7D_{hex}) via the "ADDRESS", "MSD", and "LSD" switches. The node address is polled by the firmware when the gauge is switched on. If the setting deviates from the stored value, the new value is taken over into the NVRAM. If a value >7D_{hex} (>125_{dec}) is entered, the node address setting currently stored in the device remains valid but it can now be defined via Profibus ("Set slave Address", → [2]).

Default address setting is 5C_{hex}.

Electrical connections

The gauge is connected to Profibus via the 9-pin Profibus connector (→ 22).

4.11 Switching Functions (BCG450-SD, -SP)

The gauges BCG450-SD and BCG450-SP have two independent, manually settable switching functions. Each switching function has a floating normally open relay contact ¹⁾. The relay contacts are accessible at the sensor cable connector (→ 20).

The threshold values of switching functions A and B can be set within the pressure range 1×10^{-9} mbar ... 1000 mbar via potentiometers "SETPOINT A" and "SETPOINT B".

$$U_{\text{Threshold}} = 0.75 \times (\log p_{\text{Setpoint}} - c) + 7.75$$

where constant c is pressure unit dependent (→ Appendix A).

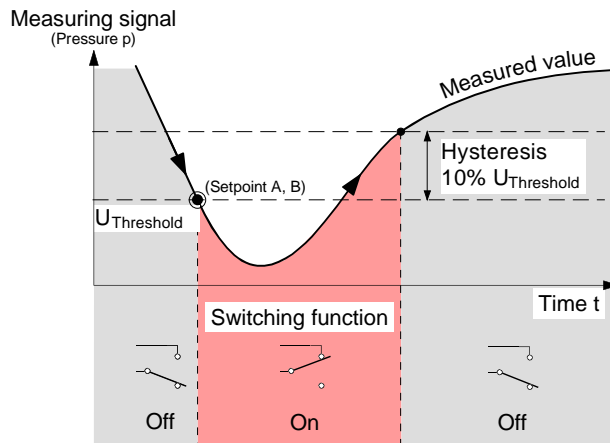

The hysteresis of the switching functions is 10% of the threshold setting.

¹⁾ Both setpoint relays (SP A/B, → 20) can be reprogrammed by the user to work as atmosphere switching function relays (→ 30 and [1] or [2]) (SP A/B = default setting).

4.11.1 Setting the Switching Functions

The threshold values of the two switching functions "SETPOINT A" and "SETPOINT B" are set locally on the potentiometers of the gauge that are accessible via the openings on one side of the gauge housing.

Required tools

- Voltmeter
- Ohmmeter or continuity checker
- Screwdriver, max. $\varnothing 2.5$ mm

Procedure

The procedure for setting thresholds is identical for both switching functions.

- 1 Put the gauge into operation.
- 2 Connect the + lead of a voltmeter to the threshold measurement point of the selected switching function ("Setpoint A" Pin 3, "Setpoint B" Pin 6) and its – lead to a ground contact nearby (eg. grounded locking screw nut of connector or vacuum connection of the gauge).



The threshold voltages are referenced to ground (housing, vacuum connection), **not** to Pin 5 (common power GND 24 V supply).

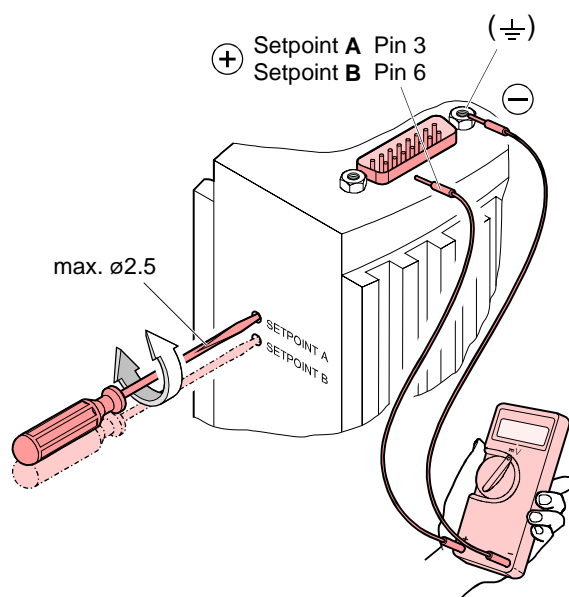

- 3 Using a screwdriver (max. $\varnothing 2.5$ mm), set the voltage of the selected switching function (Setpoint A, B) to the desired value $U_{\text{Threshold}}$.



Setting of the switching functions is now concluded.



There is no local visual indication of the statuses of the switching functions. However, a functional check of the switching functions (On/Off) can be made with one of the following methods:

- Reading the status via fieldbus interface → [1] for BCG450-SD, → [2] for BCG450-SP.
- Measurement of the relay contacts at the sensor cable connector with a ohmmeter/continuity checker (→ 20).

5 Deinstallation

DANGER



Caution: contaminated parts

Contaminated parts can be detrimental to health and environment.

Before beginning to work, find out whether any parts are contaminated. Adhere to the relevant regulations and take the necessary precautions when handling contaminated parts.

Caution



Caution: vacuum component

Dirt and damages impair the function of the vacuum component.

When handling vacuum components, take appropriate measures to ensure cleanliness and prevent damages.

Caution



Caution: dirt sensitive area

Touching the product or parts thereof with bare hands increases the desorption rate.

Always wear clean, lint-free gloves and use clean tools when working in this area.

Procedure

- 1 Vent the vacuum system.



Before taking the gauge out of operation, make sure that this has no adverse effect on the vacuum system.

Depending on the programming of the superset controller, faults may occur or error messages may be triggered.

Follow the appropriate shut-down and starting procedures.

- 2 Take gauge out of operation, switch off power supply.
- 3 Disconnect all cables from the gauge.

- 4 Remove gauge from the vacuum system and replace the protective lid.

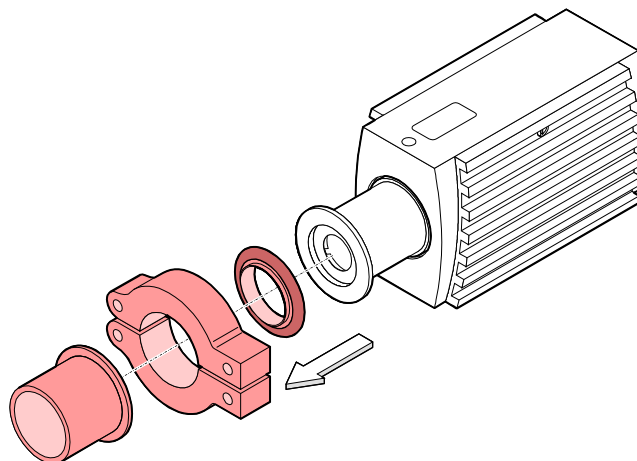

6 Maintenance, Repair

6.1 Maintenance



DANGER

Caution: contaminated parts

Contaminated parts can be detrimental to health and environment.

Before beginning to work, find out whether any parts are contaminated. Adhere to the relevant regulations and take the necessary precautions when handling contaminated parts.

6.1.1 Cleaning the Gauge

Small deposits on the electrode system can be removed by baking the anode (Degas → 28). In the case of severe contamination, the baffle can be exchanged easily (→ 16). The sensor itself cannot be cleaned and needs to be replaced in case of severe contamination (→ 50).

A slightly damp cloth normally suffices for cleaning the outside of the unit. Do not use any aggressive or scouring cleaning agents.



Make sure that no liquid can penetrate the product. Allow the product to dry thoroughly before putting it into operation again.



Gauge failures due to contamination are not covered by the warranty.

6.2 Adjusting the Gauge

The gauge is factory-calibrated. Through the use in different climatic conditions, fitting positions, aging or contamination (→ 28) and after exchanging the sensor (→ 50) a shifting of the characteristic curve can occur. However, readjustments are automatically carried out during operation of the gauge.

6.3 Adjusting the Atmosphere Sensor

The ambient atmospheric pressure of the gauge is measured by a separate sensor built into the electronics unit of the gauge (outside the vacuum chamber).

This sensor can be calibrated against the Capacitance Diaphragm sensor in the gauge. While the gauge is in a vented state, the gauge electronics compares the output signals of the two sensors and carries out the necessary adjustments to the atmospheric pressure sensor signal.



The following adjustment procedure can only be carried out via the serial interfaces.

Adjustment via RS232 interface
(BPG450)



Vent vacuum system (or operate gauge in the deinstalled state)

- ② Two 5 byte long command strings have to be sent to the gauge in succession (general RS232 information → 34):

String No. 1 (Unlock atmosphere sensor adjustment):

Byte No.	Function	Value	Comment
0	Length of data string	0x03 hex	set value
1	Data	0x10 hex	
2	Data	0x1C hex	
3	Data	0x00 hex	
4	Check sum (of bytes No. 1 ... 3)	0x2C hex	low byte of sum, high byte is ignored

String No. 2 (execute sensor adjustment):

Byte No.	Function	Value	Comment
0	Length of data string	0x03 hex	set value
1	Data	0x40 hex	
2	Data	0x20 hex	
3	Data	0x01 hex	
4	Check sum (of bytes No. 1 ... 3)	0x61 hex	low byte of sum, high byte is ignored



After the conclusion of this procedure, the separate atmospheric pressure sensor is calibrated to match the Capacitance Diaphragm sensor.

6.4 What to Do in Case of Problems

Required tools / material

In the event of a fault or a complete failure of the output signal, the gauge can easily be checked.

- Voltmeter / ohmmeter
- Allen key, size 2.5 mm
- Spare sensor (if the sensor is faulty)

Troubleshooting (BCG450)

The output signal is available at the sensor cable connector (Pin 2 and Pin 12).



In case of an error, it may be helpful to just turn off the mains supply and turn it on again after 5 s.

Problem	Possible cause	Correction
Output signal permanently $\approx 0V$	Sensor cable defective or not correctly connected	Check the sensor cable
	No supply voltage	Turn on the power supply
	Gauge in an undefined status	Turn the gauge off and on again after 5 s (reset)
Output signal +0.1 V Display: "FAIL EL "	EEPROM error	Turn the gauge off and on again after 5 s (reset) Replace electronics
Output signal +0.1 V Display: "FAIL Cap"	Diaphragm sensor error (sensor defective)	Replace the sensor (→ 50)
Output signal +0.3 V Display: "FAIL Ion"	Hot cathode error (sensor defective)	Replace the sensor (→ 50)
Output signal +0.5 V Display: "FAIL Pir"	Pirani error (sensor defective)	Replace the sensor (→ 50)
	Electronics unit not mounted correctly on sensor	Check the connections (Electronics — sensor)
Display: "no Signal"	Internal data connection not working	Turn the gauge off and on again after 5 s Replace the electronics unit

Troubleshooting (sensor)

If the cause of a fault is suspected to be in the sensor, the following checks can be made with an ohmmeter (the vacuum system need not be vented for this purpose). Separate the sensor from the electronics unit (→ 15). Using an ohmmeter, make the following measurements on the contact pins.

Ohmmeter measurement between pins			Possible cause
2 + 4	$\approx 37 \Omega$	$\gg 37 \Omega$	Pirani element 1 broken
4 + 5	$\approx 37 \Omega$	$\gg 37 \Omega$	Pirani element 2 broken
6 + 7	$\approx 0.15 \Omega$	$\gg 0.15 \Omega$	Filament of hot cathode broken
4 + 10	∞	$\ll \infty$	Electrode - short circuit to ground
6 + 10	∞	$\ll \infty$	Electrode - short circuit to ground
3 + 10	∞	$\ll \infty$	Electrode - short circuit to ground
9 + 10	∞	$\ll \infty$	Electrode - short circuit to ground
6 + 3	∞	$\ll \infty$	Short circuit between electrodes
9 + 3	∞	$\ll \infty$	Short circuit between electrodes



All unmarked pins in the diagram are used by the diaphragm sensor electronics and cannot be utilized for diagnostic purposes (do not connect an ohm meter/continuity checker to these pins).

View on sensor pins

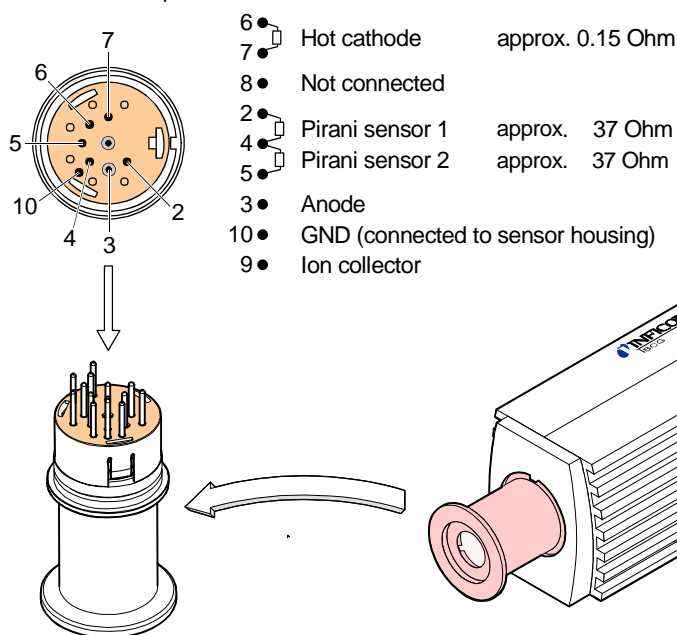

Correction

All of the above faults can only be remedied by replacing the sensor (→ 50).

Troubleshooting on Fieldbus Gauges (BCG450-SD, -SP)

Error diagnosis of fieldbus gauges can only be performed as described above for the basic sensor and sensor electronics. Diagnosis of the fieldbus interface can only be done via the superset bus controller (→ [1], [2]).

For diagnosis of the BCG450-SD (DeviceNet) gauges, the status lights might produce some useful information (→ 40).

6.5 Replacing the Sensor

Replacement is necessary, when

- the sensor is severely contaminated
- the sensor is mechanically deformed
- the sensor is faulty, e.g. filament of hot cathode broken (→ [48](#))
- the sensor is faulty, e.g. Pirani element broken (→ [48](#))

Required tools / material

- Allen key, size 2.5 mm
- Spare sensor (→ [51](#))

Procedure

- 1** Deinstall the gauge (→ [44](#)).
- 2** Deinstall the electronics unit from the faulty sensor and mount it to the new sensor (→ [15](#)).

7 Options

	Part number
24 VDC power supply / RS232C line (→ 16)	353-511
Baffle DN 25 ISO-KF / DN 40 CF-R (→ 16)	353-512

8 Spare Parts

When ordering spare parts, always indicate:

- All information on the product nameplate
- Description and part number

	Part number
Replacement sensor BCG450, vacuum connection DN 25 ISO-KF (including Allen key)	354-492
Replacement sensor BCG450, vacuum connection DN 40 CF-R (including Allen key)	354-493

9 Storage



Caution





Caution: vacuum component

Inappropriate storage leads to an increase of the desorption rate and/or may result in mechanical damage of the product.

Cover the vacuum ports of the product with protective lids or grease free aluminum foil. Do not exceed the admissible storage temperature range (→ 11).

10 Returning the Product

**WARNING**



Caution: forwarding contaminated products

Contaminated products (e.g. radioactive, toxic, caustic or biological hazard) can be detrimental to health and environment.

Products returned to INFICON should preferably be free of harmful substances. Adhere to the forwarding regulations of all involved countries and forwarding companies and enclose a duly completed declaration of contamination (→  57).

Products that are not clearly declared as "free of harmful substances" are decontaminated at the expense of the customer.

Products not accompanied by a duly completed declaration of contamination are returned to the sender at his own expense.

11 Disposal

**DANGER**



Caution: contaminated parts

Contaminated parts can be detrimental to health and environment.

Before beginning to work, find out whether any parts are contaminated. Adhere to the relevant regulations and take the necessary precautions when handling contaminated parts.

**WARNING**



Caution: substances detrimental to the environment

Products or parts thereof (mechanical and electric components, operating fluids etc.) can be detrimental to the environment.

Dispose of such substances in accordance with the relevant local regulations.

Separating the components

After disassembling the product, separate its components according to the following criteria:

Contaminated components

Contaminated components (radioactive, toxic, caustic or biological hazard etc.) must be decontaminated in accordance with the relevant national regulations, separated according to their materials, and disposed of.

Other components

Such components must be separated according to their materials and recycled.

Appendix

A: Relationship Measuring Signal – Pressure

Conversion formulae

$$p = 10^{(U - 7.75) / 0.75 + c}$$

$$U = 0.75 \times (\log p - c) + 7.75$$

where

U	p	c
[V]	[mbar]	0
[V]	[Pa]	2
[V]	[Torr]	-0.125

Conversion curve

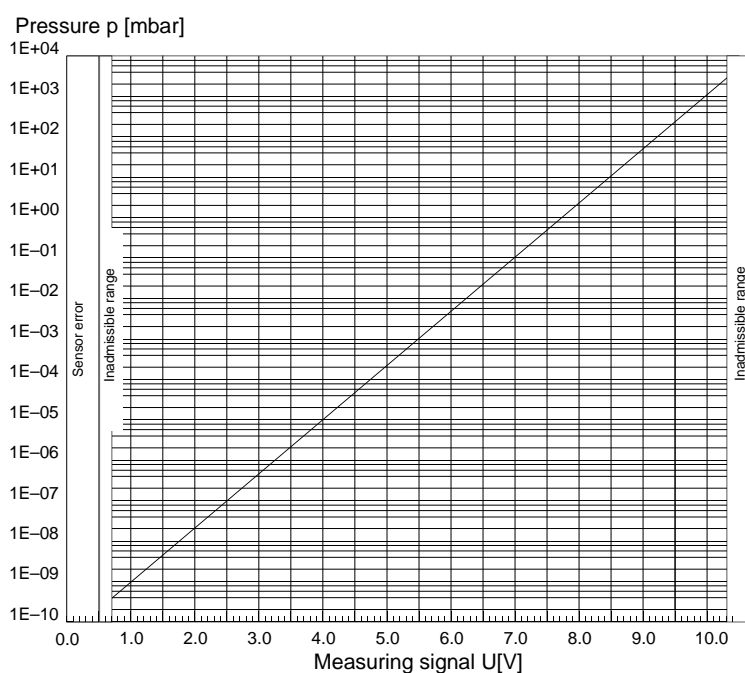

Conversion table

Output signal U [V]	[mbar]	Pressure p [Torr]	[Pa]
0.1 / 0.3 / 0.5		Sensor error (→ 48)	
0.51 ... 0.774		Inadmissible range	
0.774	5×10^{-10}	3.75×10^{-10}	5×10^{-8}
1.00	1×10^{-9}	7.5×10^{-10}	1×10^{-7}
1.75	1×10^{-8}	7.5×10^{-9}	1×10^{-6}
2.5	1×10^{-7}	7.5×10^{-8}	1×10^{-5}
3.25	1×10^{-6}	7.5×10^{-7}	1×10^{-4}
4.00	1×10^{-5}	7.5×10^{-6}	1×10^{-3}
4.75	1×10^{-4}	7.5×10^{-5}	1×10^{-2}
5.50	1×10^{-3}	7.5×10^{-4}	1×10^{-1}
6.25	1×10^{-2}	7.5×10^{-3}	1×10^0
7.00	1×10^{-1}	7.5×10^{-2}	1×10^1
7.75	1×10^0	7.5×10^{-1}	1×10^2
8.50	1×10^1	7.5×10^0	1×10^3
9.25	1×10^2	7.5×10^1	1×10^4
10.00	1×10^3	7.5×10^2	1×10^5
>10.13		Inadmissible range	

B: Gas Type Dependence

Indication range
above 10^{-2} mbar

Pressure indicated (gauge adjusted for air)

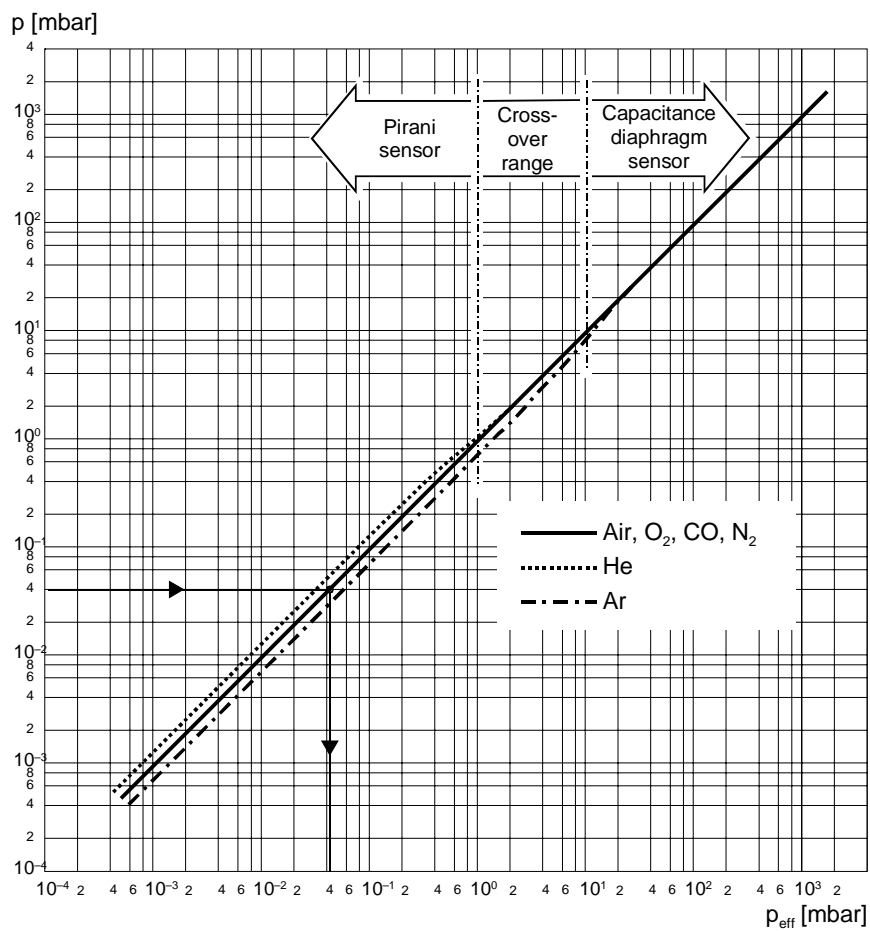

Calibration in pressure range
 10^{-2} ... 1 mbar

The gas type dependence in the pressure range 10^{-2} ... 1 mbar (Pirani sensor range) can be compensated by means of the following formula:

$$p_{\text{eff}} = C \times \text{indicated pressure}$$

where	Gas type	Calibration factor
	He	0.8
	Ne	1.4
	Ar	1.7
	Kr	2.4
	Xe	3
	H ₂	0.5
	Air, O ₂ , CO, N ₂	1
	CO ₂	0.9
	Water vapor	0.5
	Freon 12	0.7

(The above calibration factors are mean values.)

Calibration in pressure range
 $<10^{-3}$ mbar

The gas type dependence in the pressure range $<10^{-3}$ mbar can be compensated by means of the following formula (gauge adjusted for air):

$$p_{\text{eff}} = C \times \text{indicated pressure}$$

where	Gas type	Calibration factor C
	He	5.9
	Ne	4.1
	Ar	0.8
	Kr	0.5
	Xe	0.4
	H ₂	2.4
	Air, O ₂ , CO, N ₂	1

(The above calibration factors are mean values.)



A mixture of gases and vapors is often involved. In this case, accurate determination is only possible with a partial-pressure measuring instrument.

C: Literature

- [1] www.inficon.com
Communication Protocol
DeviceNet™ BCG450-SD
tira40e1
INFICON AG, LI-9496 Balzers, Liechtenstein
- [2] www.inficon.com
Communication Protocol
Profibus BCG450-SP
tira41e1
INFICON AG, LI-9496 Balzers, Liechtenstein
- [3] www.inficon.com
Product descriptions and downloads
INFICON AG, LI-9496 Balzers, Liechtenstein
- [4] www.odva.org
Open DeviceNet Vendor Association, Inc.
DeviceNet™ Specifications
- [5] www.profibus.com
Profibus user organization
- [6] European Standard for DeviceNet EN 50325
- [7] European Standard for Profibus EN 50170
- [8] www.inficon.com
Instruction Sheet
TripleGauge™ BCG450, BCG450-SD, BCG450-SP
tima40e1
INFICON AG, LI-9496 Balzers, Liechtenstein
- [9] www.inficon.com
Instruction Sheet
TripleGauge™ BCG450-SD, BCG450-SP
tima41e1
INFICON AG, LI-9496 Balzers, Liechtenstein

Declaration of Contamination

The service, repair, and/or disposal of vacuum equipment and components will only be carried out if a correctly completed declaration has been submitted. Non-completion will result in delay.

This declaration may only be completed (in block letters) and signed by authorized and qualified staff.

1 Description of product
 Type _____
 Part number _____
 Serial number _____

2 Reason for return

3 Operating fluid(s) used (Must be drained before shipping.)

4 Used in copper process
 no yes → Seal product in plastic bag and mark it with a corresponding label.

5 Process related contamination of product:

toxic	no <input type="checkbox"/> 1)	yes <input type="checkbox"/>	 2) Products thus contaminated will not be accepted without written evidence of decontamination.
caustic	no <input type="checkbox"/> 1)	yes <input type="checkbox"/>	
biological hazard	no <input type="checkbox"/>	yes <input type="checkbox"/> 2)	
explosive	no <input type="checkbox"/>	yes <input type="checkbox"/> 2)	
radioactive	no <input type="checkbox"/>	yes <input type="checkbox"/> 2)	
other harmful substances	no <input type="checkbox"/> 1)	yes <input type="checkbox"/>	

1) or not containing any amount of hazardous residues that exceed the permissible exposure limits

The product is free of any substances which are damaging to health.
 yes

6 Harmful substances, gases and/or by-products
 Please list all substances, gases, and by-products which the product may have come into contact with:

Trade/product name	Chemical name (or symbol)	Precautions associated with substance	Action if human contact

7 Legally binding declaration:
 We hereby declare that the information on this form is complete and accurate and that we will assume any further costs that may arise. The contaminated product will be dispatched in accordance with the applicable regulations.

Organization/company _____

Address _____ Post code, place _____

Phone _____ Fax _____

Email _____

Name _____

Date and legally binding signature _____ Company stamp _____

This form can be downloaded from our website.

Copies: Original for addressee - 1 copy for accompanying documents - 1 copy for file of sender

Notes

Notes

Original: German tina40d1-a (2005-04)



tira40e1-a



*LI-9496 Balzers
Liechtenstein
Tel +423 / 388 3111
Fax +423 / 388 3700
reachus@inficon.com*

www.inficon.com