

Bayard-Alpert Pirani Gauge

- BPG400
- BPG400-SD
- BPG400-SP
- BPG400-SR

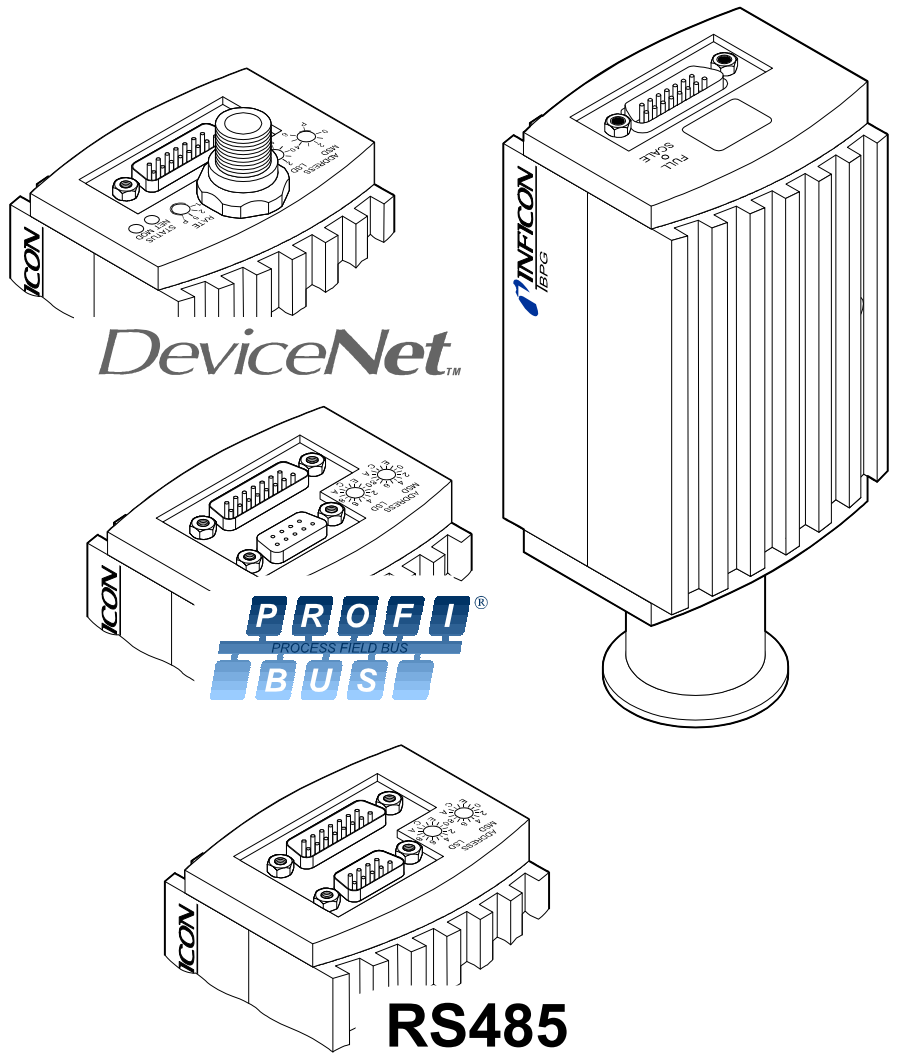

Product Identification

In all communications with INFICON, please specify the information on the product nameplate. For convenient reference copy that information into the space provided below.

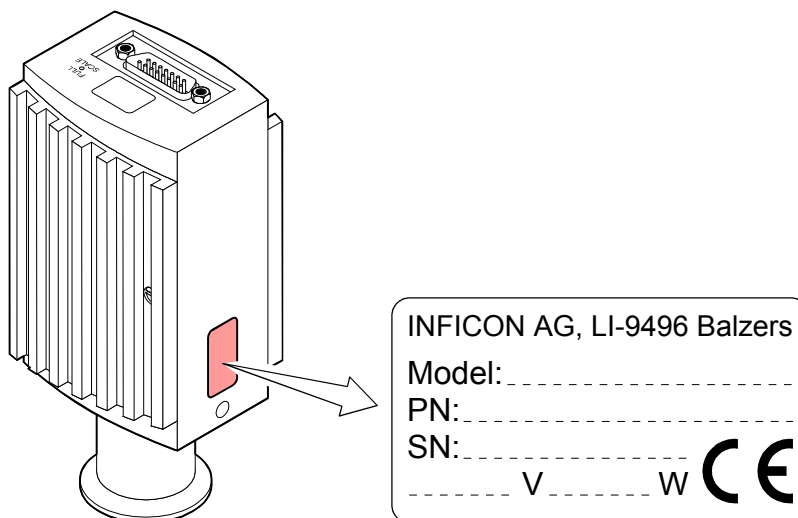

Validity

This document applies to products with the following part numbers:

BPG400 (without display)

- 353-500 (vacuum connection DN 25 ISO-KF)
- 353-502 (vacuum connection DN 40 CF-R)

BPG400 (with display)

- 353-501 (vacuum connection DN 25 ISO-KF)
- 353-503 (vacuum connection DN 40 CF-R)

BPG400-SD (with DeviceNet interface and switching functions)

- 353-507 (vacuum connection DN 25 ISO-KF)
- 353-508 (vacuum connection DN 40 CF-R)

BPG400-SP (with Profibus interface and switching functions)

- 353-505 (vacuum connection DN 25 ISO-KF)
- 353-506 (vacuum connection DN 40 CF-R)

BPG400-SR (with RS485 interface and switching functions)

- 353-509 (vacuum connection DN 25 ISO-KF)
- 353-513 (vacuum connection DN 40 CF-R)

The part number (PN) can be taken from the product nameplate.



If not indicated otherwise in the legends, the illustrations in this document correspond to gauge with part number 353-500. They apply to the other gauges by analogy.

All BPG400 versions are shipped with an instruction sheet (→ [8]). BPG400-SD, BPG400-SP and BPG400-SR come with a supplementary instruction sheet describing the fieldbus interfaces and the switching functions (→ [9]).

We reserve the right to make technical changes without prior notice.

Intended Use

The BPG400 gauges have been designed for vacuum measurement of non-flammable gases and gas mixtures in a pressure range of 5×10^{-10} ... 1000 mbar.

The gauges can be operated in connection with the INFICON Vacuum Gauge Controller VGC103 or VGC40x or with other control devices.

Functional Principle

Over the whole measuring range, the gauge has a continuous characteristic curve and its measuring signal is output as logarithm of the pressure.

The gauge functions with a Bayard-Alpert hot cathode ionization measurement system (for $p < 2.0 \times 10^{-2}$ mbar) and a Pirani measurement system (for $p > 5.5 \times 10^{-3}$ mbar). In the overlapping pressure range of $2.0 \times 10^{-2} \dots 5.5 \times 10^{-3}$ mbar, a mixed signal of the two measurement systems is output. The hot cathode is switched on by the Pirani measurement system only below the switching threshold of 2.4×10^{-2} mbar (to prevent filament burn-out). It is switched off when the pressure exceeds 3.2×10^{-2} mbar.



Trademarks

DeviceNet™ Open DeviceNet Vendor Association, Inc.

Contents

Product Identification	2
Validity	2
Intended Use	2
Functional Principle	3
Trademarks	3
1 Safety	6
1.1 Symbols Used	6
1.2 Personnel Qualifications	6
1.3 General Safety Instructions	7
1.4 Liability and Warranty	7
2 Technical Data	8
3 Installation	13
3.1 Vacuum Connection	13
3.1.1 Removing and Installing the Electronics Unit	14
3.1.2 Installing the Optional Extension	16
3.1.3 Using the Optional Baffle	17
3.2 Electrical Connection	19
3.2.1 Use With INFICON VGC103 or VGC40x Vacuum Gauge Controller	19
3.2.2 Use With Other Controllers	19
3.2.2.1 Making an Individual Sensor Cable	20
3.2.2.2 Making a DeviceNet Interface Cable (BPG400-SD)	22
3.2.2.3 Making a Profibus Interface Cable (BPG400-SP)	23
3.2.2.4 Making a RS485 Interface Cable (BPG400-SR)	24
3.2.3 Using the Optional Power Supply (With RS232C Line)	25
4 Operation	27
4.1 Measuring Principle, Measuring Behavior	27
4.2 Operational Principle of the Gauge	28
4.3 Putting the Gauge Into Operation	29
4.4 Degas	29
4.5 Display (BPG400)	30
4.6 RS232C Interface	31
4.6.1 Description of the Functions	31
4.6.1.1 Output String (Transmit)	31
4.6.1.2 Input String (Receive)	33
4.7 DeviceNet Interface (BPG400-SD)	34
4.7.1 Description of the Functions	34
4.7.2 Operating Parameters	34
4.7.2.1 Operating Software	34
4.7.2.2 Node Address Setting	34
4.7.2.3 Data Rate Setting	35
4.7.3 Status Lights	35
4.8 Profibus Interface (BPG400-SP)	36
4.8.1 Description of the Functions	36
4.8.2 Operating Parameters	36
4.8.2.1 Operating Software	36
4.8.2.2 Node Address Setting	36
4.9 RS485 Interface (BPG400-SR)	37
4.9.1 Description of the Functions and Modes	37
4.9.2 Data Exchange	37
4.9.2.1 Operational Parameters	37
4.9.2.2 Device Address	38
4.9.2.3 Command Structure (Host)	38
4.9.2.4 Response Structure	38
4.9.2.5 Error Messages	38
4.9.3 Syntax Description	39
4.9.3.1 Definitions, Legend	39
4.9.3.2 Commands and Responses	40
4.9.4 Switching Functions	42
4.9.4.1 Programming the Switching Functions	43
4.10 Switching Functions (BPG400-SD, -SP, -SR)	44
4.10.1 Setting the Switching Functions	44

5 Deinstallation	46
6 Maintenance, Repair	47
6.1 Maintenance	47
6.1.1 Cleaning the Gauge	47
6.2 Adjusting the Gauge	47
6.2.1 Adjustment at Atmospheric Pressure	47
6.2.2 Zero Point Adjustment	48
6.3 What to Do in Case of Problems	49
6.4 Replacing the Sensor	51
7 Options	52
8 Spare Parts	52
9 Storage	52
10 Returning the Product	53
11 Disposal	53
Appendix	54
A: Relationship Output Signal – Pressure	54
B: Gas Type Dependence	55
C: Literature	57
Declaration of Contamination	58

For cross-references within this document, the symbol (→  XY) is used, for cross-references to further documents and data sources, the symbol (→  [Z]).

1 Safety

1.1 Symbols Used

DANGER

Information on preventing any kind of physical injury.

WARNING

Information on preventing extensive equipment and environmental damage.

Caution

Information on correct handling or use. Disregard can lead to malfunctions or minor equipment damage.



Notice



Hint, recommendation



The result is O.K.



The result is not as expected



Optical inspection



Waiting time, reaction time

1.2 Personnel Qualifications

Skilled personnel

All work described in this document may only be carried out by persons who have suitable technical training and the necessary experience or who have been instructed by the end-user of the product.

1.3 General Safety Instructions

- Adhere to the applicable regulations and take the necessary precautions for the process media used.
Consider possible reactions between the materials (→ 11) and the process media.
Consider possible reactions of the process media (e.g. explosion) due to the heat generated by the product.
- Adhere to the applicable regulations and take the necessary precautions for all work you are going to do and consider the safety instructions in this document.
- Before beginning to work, find out whether any vacuum components are contaminated. Adhere to the relevant regulations and take the necessary precautions when handling contaminated parts.

Communicate the safety instructions to all other users.

1.4 Liability and Warranty

INFICON assumes no liability and the warranty becomes null and void if the end-user or third parties

- disregard the information in this document
- use the product in a non-conforming manner
- make any kind of interventions (modifications, alterations etc.) on the product
- use the product with accessories not listed in the corresponding product documentation.

The end-user assumes the responsibility in conjunction with the process media used.

2 Technical Data

Measurement	Measuring range (air, N ₂ , O ₂)	5×10 ⁻¹⁰ ... 1000 mbar, continuous
	Accuracy	15% of reading in the range of 10 ⁻⁸ ... 10 ⁻² mbar (after 5 min stabilization)
	Repeatability	5% of reading in the range of 10 ⁻⁸ ... 10 ⁻² mbar (after 5 min stabilization)
	Gas type dependence	→ Appendix B

Emission	Switching on threshold	2.4×10 ⁻² mbar
	Switching off threshold	3.2×10 ⁻² mbar
	Emission current	
	p ≤ 7.2×10 ⁻⁶ mbar	5 mA
	7.2×10 ⁻⁶ mbar < p < 3.2×10 ⁻² mbar	25 μA
Emission current switching		
25 μA ⇒ 5 mA	7.2×10 ⁻⁶ mbar	
5 mA ⇒ 25 μA	3.2×10 ⁻⁵ mbar	

Degas	Degas emission current (p < 7.2×10 ⁻⁶ mbar)	≈16 mA (P _{degas} ≈4 W)
	Control input signal	0 V/+24 VDC, active high (control via RS232 → 31)
	Duration	max. 3 min, followed by automatic stop

In degas mode, BPG400 gauges keep supplying measurement values, however their tolerances may be higher than during normal operation.

Output signal	Output signal (measuring signal)	0 ... +10 V
	Measuring range	0.774 V (5×10 ⁻¹⁰ mbar) ... +10 V (1000 mbar)
	Relationship voltage-pressure	logarithmic, 0.75 V/decade (→ Appendix A)
	Error signal	<0.3 V/0.5 V (→ 49)
	Minimum loaded impedance	10 kΩ

Display (BPG400)	Display panel	LCD matrix, 32×16 pixels, with background illumination
	Dimensions	16.0 mm × 11.2 mm
	Pressure units (pressure p)	mbar (default), Torr, Pa (selecting the pressure unit → 31)

Power supply



DANGER

The gauge must only be connected to power supplies, instruments or control devices that conform to the requirements of a grounded extra-low voltage (SELV-E according to EN 61010). The connection to the gauge has to be fused (INFICON-controllers fulfill these requirements).

Operating voltage at the gauge	+24 VDC (20 ... 28 VDC) ¹⁾ ripple max. 2 V _{pp}
Power consumption	
Standard	≤0.5 A
Degas	≤0.8 A
Emission start (<200 ms)	≤1.4 A
Power consumption	
BPG400	≤16 W
BPG400-SD, -SP, -SR	≤18 W
Fuse necessary	1.25 AT



BPG400-SD requires an additional, separate power supply for the DeviceNet interface (→ 22).

Supply voltage at the DeviceNet connector, (Pin 2 and Pin 3)	+24 VDC (+11 ... 25 VDC)
Power consumption	<2 W
The gauge is protected against reversed polarity of the supply voltage.	

Sensor cable connection



For reasons of compatibility, the expression "sensor cable" is used for all BPG400 versions in this document, although the pressure reading of the gauges with fieldbus interface (BPG400-SD, BPG400-SD and BPG400-SR) is normally transmitted via the corresponding bus.

Electrical connector	D-Sub, 15 pins, male
BPG400	→ 20
BPG400-SD, -SP, -SR	→ 21
Cable for BPG400	
Analog values only	
Without degas function	4 conductors plus shielding
Analog values	
With degas function	5 conductors plus shielding
Analog values	
With degas function	
And RS232C interface	7 conductors plus shielding
Cable for BPG400-SD, -SP, -SR	depending on the functions used, max. 15 conductors plus shielding
Max. cable length (supply voltage 24 V ¹⁾)	
Analog and fieldbus operation	≤35 m, conductor cross-section 0.25 mm ² ≤50 m, conductor cross-section 0.34 mm ² ≤100 m, conductor cross-section 1.0 mm ²
RS232C operation	≤30 m
Gauge identification	42 kΩ resistor between Pin 10 (sensor cable) and GND
Switching functions	
BPG400	none
BPG400-SD, -SP, -SR	2 (setpoints A and B)
Adjustment range	1×10 ⁻⁹ mbar ... 100 mbar
	Setpoints adjustable via potentiometers (setpoints A and B), one floating, normally open relay contact per setpoint (→ 21, 44)
	Adjusting the setpoints via field bus is described in the corresponding bus sections.
Relay contact rating	
Voltage	≤60 V
Current	≤0.5 ADC







¹⁾ Measured at sensor cable connector (consider the voltage drop as function of the sensor cable length).

RS232C interface







Data rate	9600 Baud
Data format	binary 8 data bits one stop bit no parity bit no handshake
Connections (sensor cable connector)	
TxD (Transmit Data)	Pin 13
RxD (Receive Data)	Pin 14
GND	Pin 5

(Function and communication protocol of the RS232C interface →  31)



DeviceNet interface (BPG400-SD)

Fieldbus name	DeviceNet
Standard applied	→  [6]
Communication protocol, data format	→  [1], [4]
Interface, physical	CAN bus
Data rate (adjustable via "RATE" switch)	125 kBaud 250 kBaud 500 kBaud "P" (125 kBaud, 250 kBaud, 500 kBaud programmable via DeviceNet (→  [1])
Node address (MAC ID) (Adjustable via "ADDRESS", "MSD", "LSD" switches)	0 ... 63 _{dec} "P" (0 ... 63 programmable via DeviceNet, →  [1])
DeviceNet connector	Micro-Style, 5 pins, male
Cable	Shielded, special DeviceNet cable, 5 conductors (→  22 and  [4])
Cable length, system wiring	According to DeviceNet specifications (→  [6], [4])

Profibus interface (BPG400-SP)

Fieldbus name	Profibus
Standard applied	→  [7]
Communication protocol data format	→  [10], [7]
Interface, physical	RS485
Data rate	≤12 MBaud (→  [10])
Node address	
Local (Adjustable via hexadecimal "ADDRESS", "MSD", "LSD" switches)	00 ... 7D _{hex} (0 ... 125 _{dec})
Via Profibus (hexadecimal "ADDRESS" switches set to >7d _{hex} (>125 _{dec}))	00 ... 7D _{hex} (0 ... 125 _{dec})
Profibus connection	D-Sub, 9 pins, female
Cable	Shielded, special Profibus cable (→  23 and  [5])
Cable length, system wiring	According to Profibus specifications (→  [7], [5])

**RS485 interface
(BPG400-SR)**

Fieldbus name	RS485
Data rate	300 ... 28'800 Baud
Device address (Adjustable via hexadecimal "ADDRESS", "MSD", "LSD" switches)	00 ... 7F _{hex} (0 ... 127 _{dec}), (→  38)
RS485 connection	D-Sub, 9 pins, male
Cable	shielded RS485 cable (→  24)
Cable length	≤100m

Vacuum

Materials exposed to vacuum	
Housing, supports, screens	stainless steel
Feedthroughs	NiFe, nickel plated
Insulator	glass
Cathode	iridium, yttrium oxide (Y ₂ O ₃)
Cathode holder	molybdenum
Pirani element	tungsten, copper
Internal volume	
DN 25 ISO-KF	≤24 cm ³
DN 40 CF-R	≤34 cm ³
Pressure max.	2 bar (absolute)

Weight

Part number	
353-500, 353-501	≈290 g
353-502, 353-503	≈550 g
353-505, 353-507, 353-509	≈430 g
353-506, 353-508, 353-513	≈695 g

Ambiance

Admissible temperatures	
Storage	-20 ... 70 °C
Operation	0 ... 50 °C
Bakeout	+150 °C (without electronics unit or with bakeout extension →  16)
Relative humidity (year's mean / during 60 days)	≤65 / 85% (no condensation)
Use	indoors only altitude up to 2000 m NN
Type of protection	IP 30

Dimensions

Part number

353-500
353-501
353-505
353-509
(353-507) ¹⁾

Part number

353-502
353-503
353-506
353-513
(353-508) ¹⁾

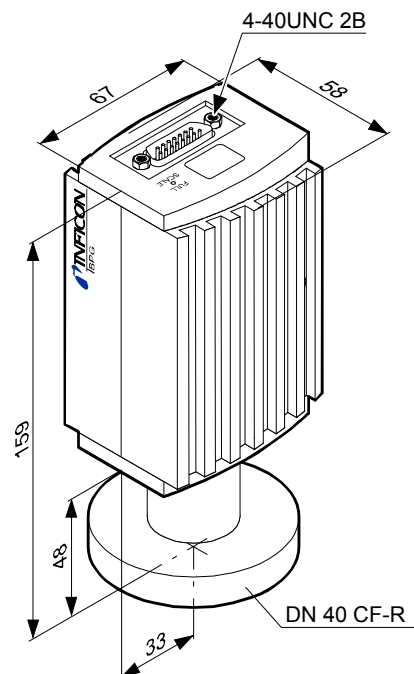
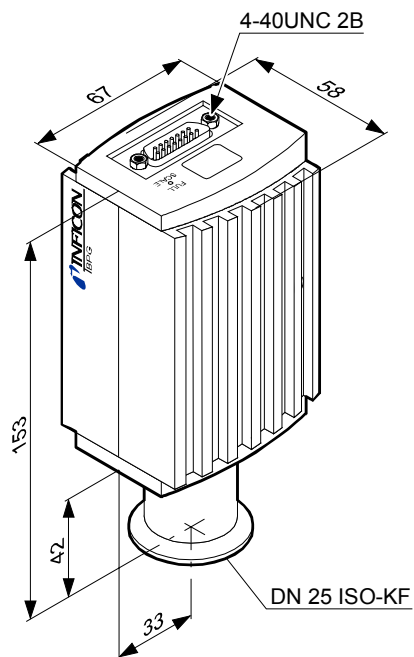

¹⁾ Gauges with DeviceNet connector are 14 mm longer.
The other dimensions of housing and vacuum connection are identical.

Part number

353-507
353-508

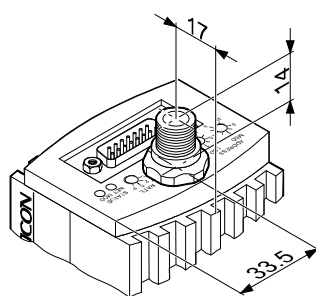

3 Installation

3.1 Vacuum Connection



DANGER

Caution: overpressure in the vacuum system >1 bar
Injury caused by released parts and harm caused by escaping process gases can result if clamps are opened while the vacuum system is pressurized.

Do not open any clamps while the vacuum system is pressurized. Use the type of clamps which are suited to overpressure.



DANGER

The gauge must be electrically connected to the grounded vacuum chamber. This connection must conform to the requirements of a protective connection according to EN 61010:

- CF connections fulfill this requirement
- For gauges with a KF vacuum connection, use a conductive metallic clamping ring.



Caution



Caution: vacuum component
Dirt and damages impair the function of the vacuum component.
When handling vacuum components, take appropriate measures to ensure cleanliness and prevent damages.



The gauge may be mounted in any orientation. To keep condensates and particles from getting into the measuring chamber, preferably choose a horizontal to upright position. See dimensional drawing for space requirements (→ [12](#)).

- The gauge is supplied with a built-in grid. For potentially contaminating applications and to protect the electrodes against light and fast charged particles, installation (→ [17](#)) of the optional baffle is recommended (→ [52](#)).
- The sensor can be baked at up to 150 °C. At temperatures exceeding 50 °C, the electronics unit has to be removed (→ [14](#)) or an extension (Option → [52](#)) has to be installed (→ [16](#)).

Procedure



Remove the protective lid.



The protective lid will be needed for maintenance.

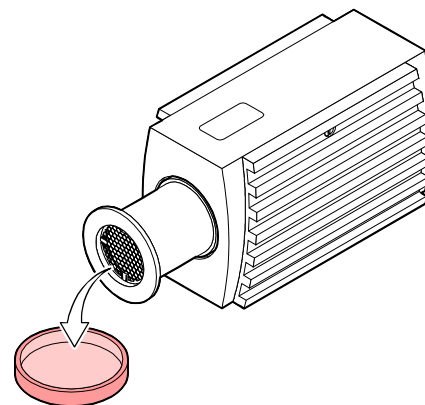

- 2 Make the flange connection to the vacuum system, preferably without applying vacuum grease.

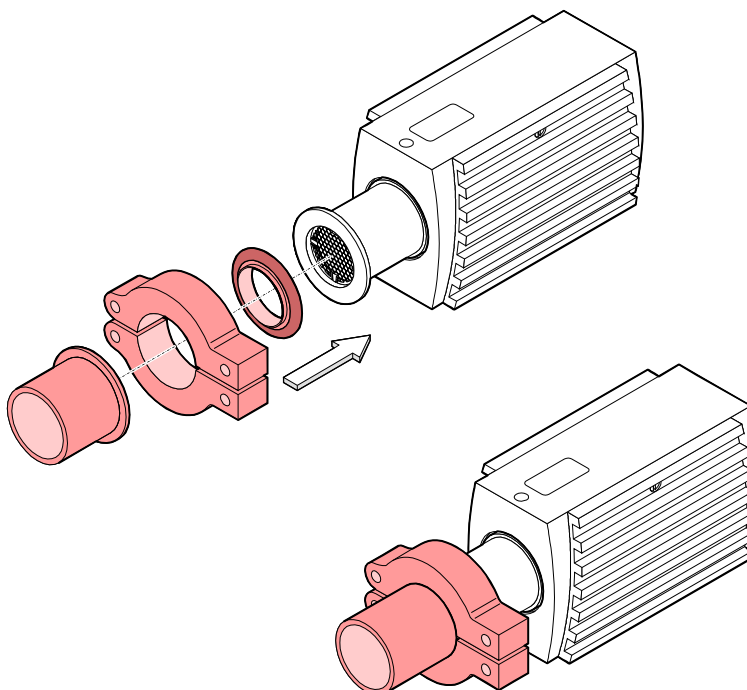

When installing the gauge, make sure that the area around the connector is accessible for the tools required for adjustment while the gauge is mounted (→ ¶ 44, 47).

When installing the gauge, allow for installing/deinstalling the connectors and accommodation of cable loops.

If you are using a gauge with display, make sure easy reading of the display is possible.



The gauge is now installed.

3.1.1 Removing and Installing the Electronics Unit

Required tools / material

- Allen key, size 2.5 mm

Removing the electronics unit

- 1 Unscrew the hexagon socket set screw (1) on the side of the electronics unit (2).

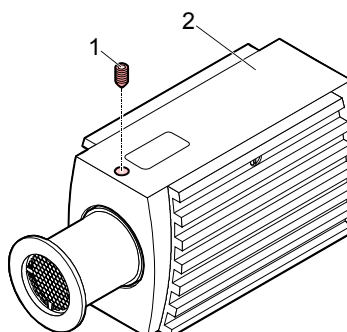

- 2 Remove the electronics unit **without twisting it**.



- ✓ Removal of the electronics unit is completed.

Installing the electronics unit

- 1 Place the electronics unit on the sensor (3) (be careful to correctly align the pins and notch (4)).

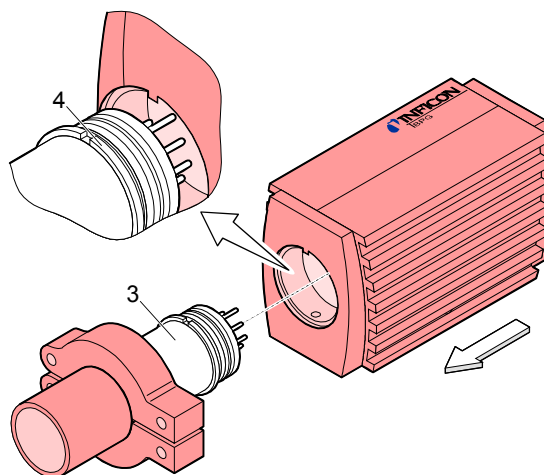

- 2 Slide the electronics unit in to the mechanical stop and lock it with the hexagon socket set screw (1).

- ✓ The electronics unit is now installed.

3.1.2 Installing the Optional Extension

With the optional extension (→ 52) the sensor can also be baked during operation at temperatures up to 150 °C (only at $p < 10^{-2}$ mbar because at high temperatures, the accuracy of the Pirani sensor decreases).

Caution

Caution: rising heat
The electronics unit of gauges that are installed vertically, above the source of heat can be damaged through rising heat even with an installed extension.

Bakeout area

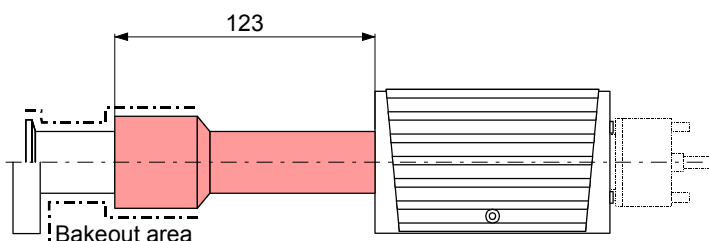

When installing the extension, make sure that the area around the connector is accessible for the tools required for adjustment while the gauge is mounted (→ 44, 47).

When installing the gauge, allow for installing/deinstalling the connectors and accommodation of cable loops.

If you are using a gauge with display, ensure easy reading of the display.

Required tools / material

- Extension (→ 52)
- Allen key, size 2.5 mm
- Allen key, size 1.5 mm

Procedure

- 1** Remove the electronics unit (2) (→ 14).
- 2** Slide the sensor (3) into the extension (6) to the mechanical stop (be careful to correctly position the pins and notch (4)).
- 3** Secure the sensor with the hex socket set screws (7) using an Allen key, size 1.5 mm.

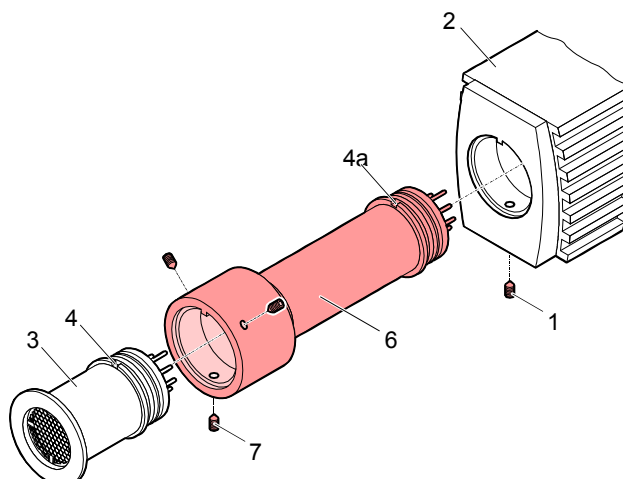

- 4 Slide the electronics unit (2) in to the mechanical stop (be careful to correctly align the pins and notch (4a)).
 - 5 Secure the electronics unit (2) with the hex socket set screw (1) using an Allen key, size 2.5 mm.
- ✓ The extension is now installed.

3.1.3 Using the Optional Baffle

In severely contaminating processes and to protect measurement electrodes optically against light and fast charged particles, replacement of the built-in grid by the optional baffle (→ 52) is recommended.

Installing/deinstalling
the baffle

The optional baffle will be installed/deinstalled at the sensor opening of the deinstalled gauge (Deinstallation gauge → 46).



Caution



Caution: dirt sensitive area

Touching the product or parts thereof with bare hands increases the desorption rate.

Always wear clean, lint-free gloves and use clean tools when working in this area.

Required tools / material

- Baffle (→ 52)
- Pointed tweezers
- Pin (e.g. pencil)
- Screwdriver No 1

Installation

- 1 Carefully remove the grid with tweezers.

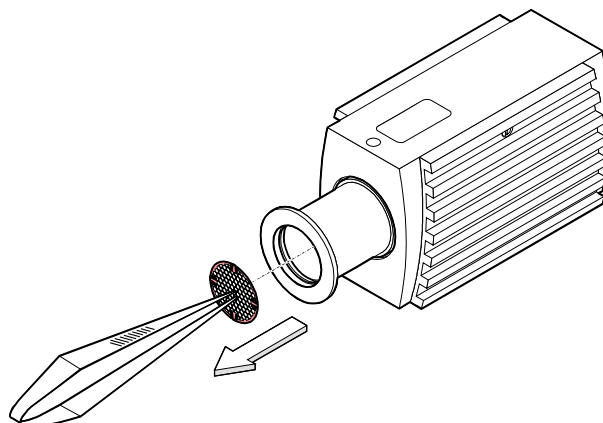

- 2** Carefully place the baffle onto the sensor opening.

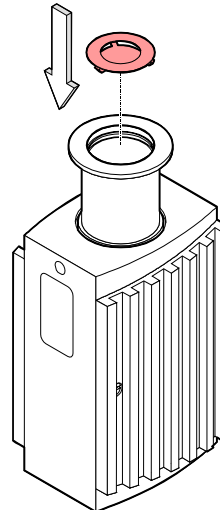

- 3** Using a pin, press the baffle down in the center until it catches.

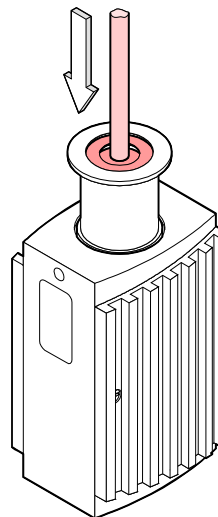

- ✓ The baffle is now installed (Installation of the gauge → [13](#)).

Deinstallation

Using a pin, press the baffle down in the center until it catches.

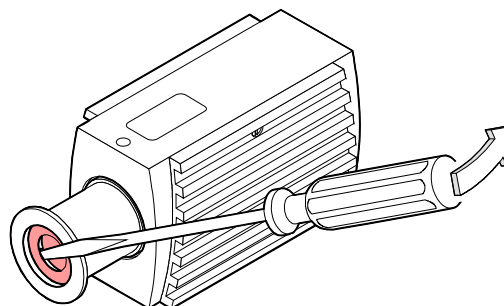

- ✓ The new baffle is now installed (Installation of the gauge → [13](#)).

3.2 Electrical Connection

3.2.1 Use With INFICON VGC103 or VGC40x Vacuum Gauge Controller

If the gauge is used with an INFICON VGC103 or VGC40x controller, a corresponding sensor cable is required (→ [10]). The sensor cable permits supplying the gauge with power, transmitting measurement values and gauge statuses, and making parameter settings.

Caution

Caution: data transmission errors

If the gauge is operated with the INFICON VGC103 or VGC40x Vacuum Gauge Controller (RS232C) and a fieldbus interface at the same time, data transmission errors may occur.

The gauge must not be operated with an INFICON VGC103 or VGC40x controller and DeviceNet, Profibus or RS485 at the same time.

Required material

- Sensor cable (→ [10], INFICON sales literature)

Procedure

- 1 Plug the sensor connector into the gauge and secure it with the locking screws.
- 2 Connect the other end of the sensor cable to the INFICON controller and secure it.

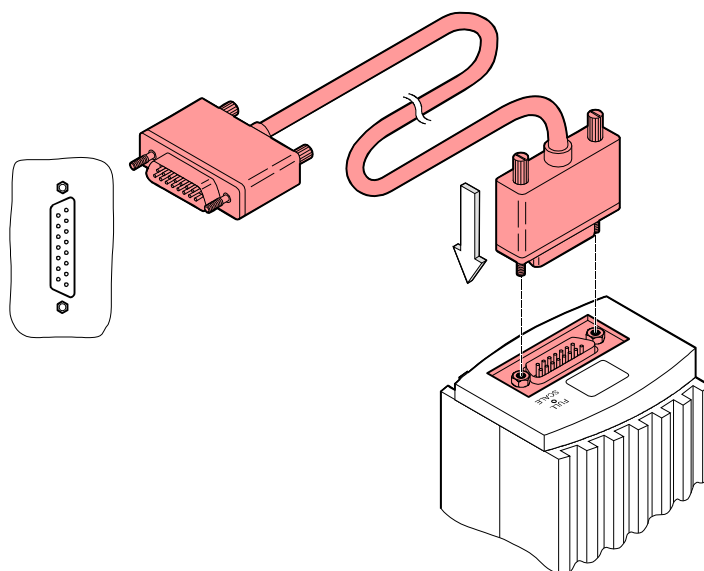

- The gauge can now be operated with the VGC103 or VGC40x controller.

3.2.2 Use With Other Controllers

The gauge can also be operated with other controllers. Especially the fieldbus versions BPG400-SD (DeviceNet), BPG400-SP (Profibus) and BPG400-SR (RS485) are usually operated as part of a network, controlled by a master or bus controller. In such cases, the control system has to be operated with the appropriate software and communication protocol (→ [1], [10] or 37 respectively).

3.2.2.1 Making an Individual Sensor Cable



For reasons of compatibility, the expression "sensor cable" is used for all BPG400 versions in this document, although the pressure reading of the gauges with fieldbus interface (BPG400-SD, BPG400-SP or BPG400-SR) is normally transmitted via DeviceNet, Profibus or RS485.

The sensor cable is required for supplying all BPG400 types with power. In connection with the gauges with fieldbus interface (BPG400-SD, BPG400-SP and BPG400-SR), it also permits access to the relay contacts of the switching functions (→ § 21, 44).

Cable type

The application and length of the sensor cable have to be considered when determining the number and cross sections of the conductors (→ § 9).

Procedure

- 1 Open the cable connector (D-Sub, 15 pins, female).
- 2 Prepare the cable and solder/crimp it to the connector as indicated in the diagram of the gauge used:

Sensor cable connection BPG400

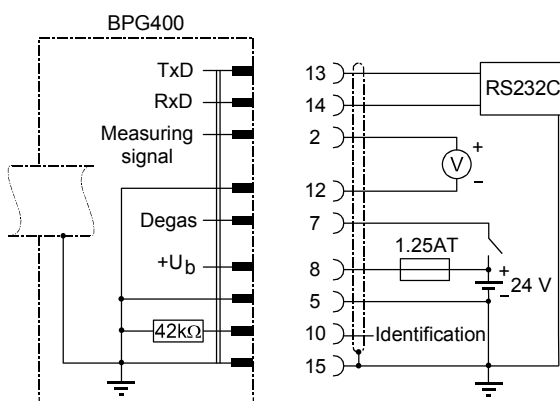

Electrical connection

Pin 2	Signal output (measuring signal)	0 ... +10 V
Pin 5	Supply common, GND	
Pin 7	Degas on, active high	+24 VDC
Pin 8	Supply	+24 VDC
Pin 10	Gauge identification	
Pin 12	Signal common, GND	
Pin 13	RS232C, TxD	
Pin 14	RS232C, RxD	
Pin 15	Shielding, housing, GND	

Pins 1, 3, 4, 6, 9 and 11 are not connected internally.

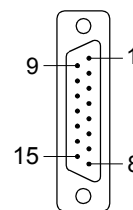

D-Sub, 15 pins female, soldering side

Sensor cable connection
BPG400-SD, -SP, -SR

BPG400-SD, BPG400-SP, BPG400-SR

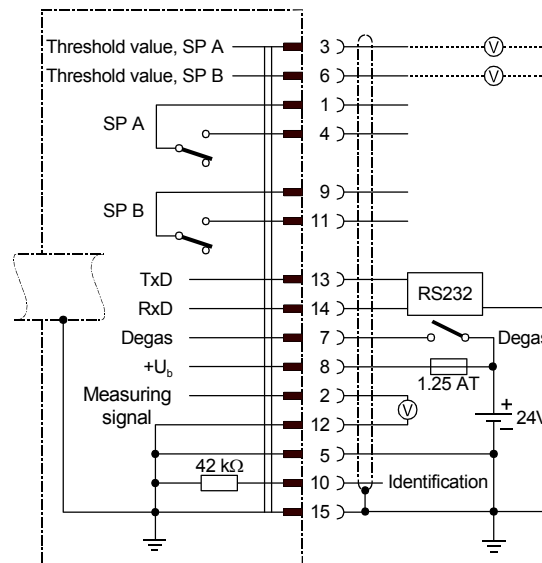

Electrical connection

- Pin 1 Relay Switching function A, COM contact
- Pin 2 Signal output (measuring signal) 0 ... +10 V
- Pin 3 Threshold value (Setpoint) A 0 ... +10 V
- Pin 4 Relay Switching function A, N.O. contact
- Pin 5 Supply common, GND
- Pin 6 Threshold value (Setpoint) B 0 ... +10 V
- Pin 7 Degas on, active high +24 V
- Pin 8 Supply voltage +24 V
- Pin 9 Relay Switching function B, COM contact
- Pin 10 Gauge identification
- Pin 11 Relay Switching function B, N.O. contact
- Pin 12 Signal common GND
- Pin 13 RS232, TxD
- Pin 14 RS232, RxD
- Pin 15 Shielding, housing GND

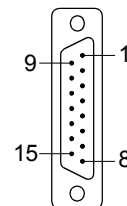

D-Sub, 15 pins female, soldering side

WARNING

The supply common (Pin 5) and the shielding (Pin 15) must be connected at the supply unit with protective ground. Incorrect connection, incorrect polarity or inadmissible supply voltages can damage the gauge.



For cable lengths up to 5 m (0.34 mm² conductor cross-section) the output signal can be measured directly between the positive signal output (Pin 2) and supply common GND (Pin 5) without loss of accuracy. At greater cable lengths, differential measurement between signal output (Pin 2) and signal common (Pin 12) is recommended.

3 Reassemble the cable connector.

4 On the other cable end, terminate the cable according to the requirements of the gauge controller you are using.

- 5 Plug the sensor connector into the gauge and secure it with the locking screws.

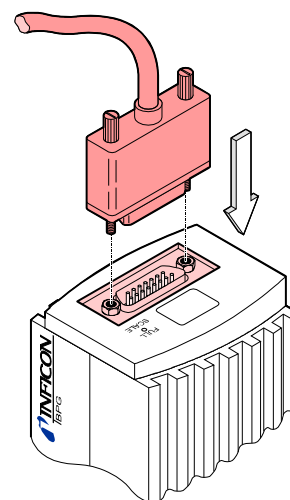

- 6 Connect the other end of the sensor cable to the connector of the instrument or gauge controller you are using.

✓ The gauge can now be operated via analog and RS232C interface.

3.2.2.2 Making a DeviceNet Interface Cable (BPG400-SD)

For operating BPG400-SD via DeviceNet, an interface cable conforming to the DeviceNet standard is required. If no such cable is available, make one according to the following indications.

Cable type

A shielded special 5 conductor cable conforming to the DeviceNet standard has to be used (→ [4], [6]).

Procedure

- 1 Make the DeviceNet cable according to the following indications.

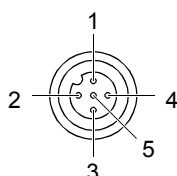

Micro-Style, 5 pins,
(DeviceNet)
female, soldering side

Pin	Function (BPG400-SD)
1	Drain
2	Supply +24 VDC (DeviceNet) interface only
3	Supply common GND (DeviceNet interface only)
4	CAN_H
5	CAN_L

- 2 Plug the DeviceNet (and sensor) cable connector into the gauge.

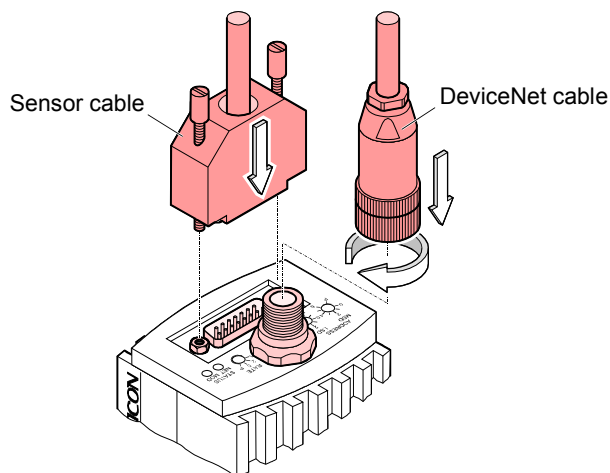

- 3 Lock the DeviceNet (and sensor) cable connector.

✓ The gauge can now be operated via DeviceNet interface (→ [34](#)).

3.2.2.3 Making a Profibus Interface Cable (BPG400-SP)

For operating BPG400-SP via Profibus, an interface cable conforming to the Profibus standard is required.

If no such cable is available, make one according to the following indications.

Cable type

Only a cable that is suited to Profibus operation may be used (→ [\[5\]](#), [\[7\]](#)).

Procedure

- 1 Make the Profibus interface cable according to the following indications:

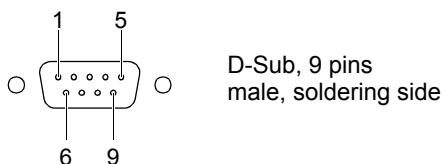

Pin Function (BPG400-SP)

1	Do not connect	
2	Do not connect	
3	RxD/TxD-P	
4	CNTR-P	1)
5	DGND	2)
6	VP	2)
7	Do not connect	
8	RxD/TxD-N	
9	Do not connect	

¹⁾ Only to be connected if an *optical link* module is used.

²⁾ Only required as line termination for devices at both ends of bus cable (→ [\[5\]](#)).

- 2 Plug the Profibus (and sensor) cable connector into the gauge.

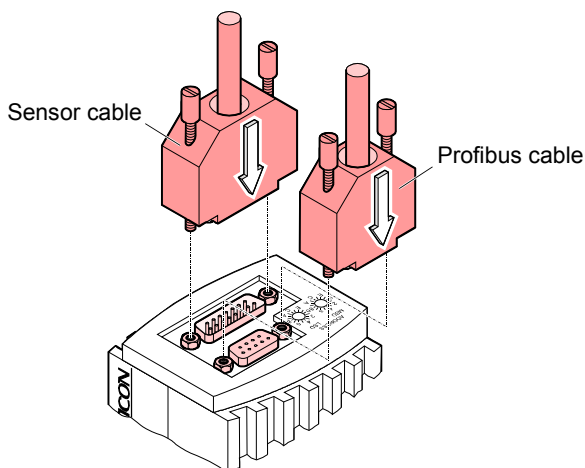

- 3 Lock the Profibus (and sensor) cable connector.

✓ The gauge can now be operated via Profibus interface (→ 36).

3.2.2.4 Making a RS485 Interface Cable (BPG400-SR)

For operating BPG400-SR via RS485 bus, a suitable interface cable is required. If no such cable is available, make one according to the following indications.

Cable type

For RS485 operation, the following cable data are required:

Cable type:	1 twisted pair, shielded
Conductor cross section:	$\geq 0.22 \text{ mm}^2$ (recommended)
Impedance (Z):	135 ... 165 Ω
Capacity between conductors and screen:	$\leq 60 \text{ pF/m}$

Procedure

- 1 Make the RS485 interface cable according to the following indications.

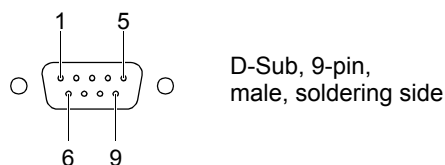

Pin 1	Setpoint A relay, N.O.	1)
Pin 2	Do not connect	
Pin 3	No connection	
Pin 4	Do not connect	
Pin 5	Setpoint A relay, N.C.	1)
Pin 6	RS485 (-) Input	2)
Pin 7	Setpoint A relay, COM	1)
Pin 8	No connection	
Pin 9	RS485 (+) Input	2)

1) The changeover relay contact available on the RS485 interface connector is galvanically connected to the N.O. contact of the setpoint A relay available on the 25 pin D-sub connector on the BPG400 (→ 21).

2) In order to minimize cable reflections, the bus cable must be terminated at both ends with appropriate termination resistors.

- 2** Plug the RS485 (and sensor) cable connector into the gauge.

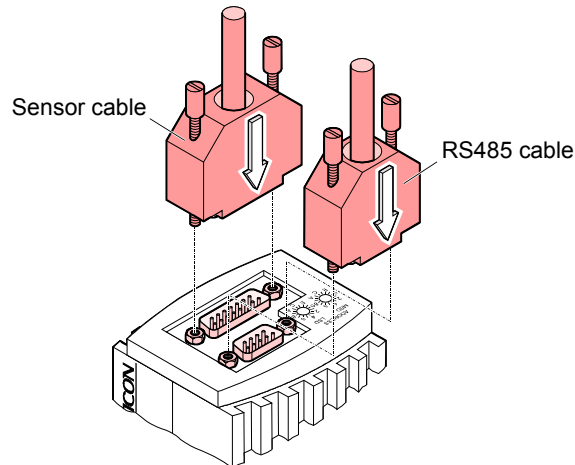

- 3** Lock the RS485 (and sensor) cable connector.

✓ The gauge can now be operated via RS485 interface (→ 37).

3.2.3 Using the Optional Power Supply (With RS232C Line)

The optional 24 V power supply (→ 52) allows RS232C operation of the BPG400 gauge with any suitable instrument or control device (e.g. PC).

The instrument or control device needs to be equipped with a software that supports the RS232C protocol of the gauge (→ 31).

Technical data

Mains connection

Mains voltage	90 ... 250 VAC 50 ... 60 Hz
Mains cable	1.8 meter (Schuko DIN and U.S. connectors)

Output (operating voltage of gauge)

Voltage	21 ... 27 VDC, set to 24 VDC
Current	Max. 1.5 A

Gauge connection

Connector	D-Sub, 15 pins, female
24 V cable	5 m, black

Connection of the instrument or control device

RS232C connection	D-Sub, 9 pins, female
Cable	5 m, black, 3 conductors, shielded

Wiring diagram

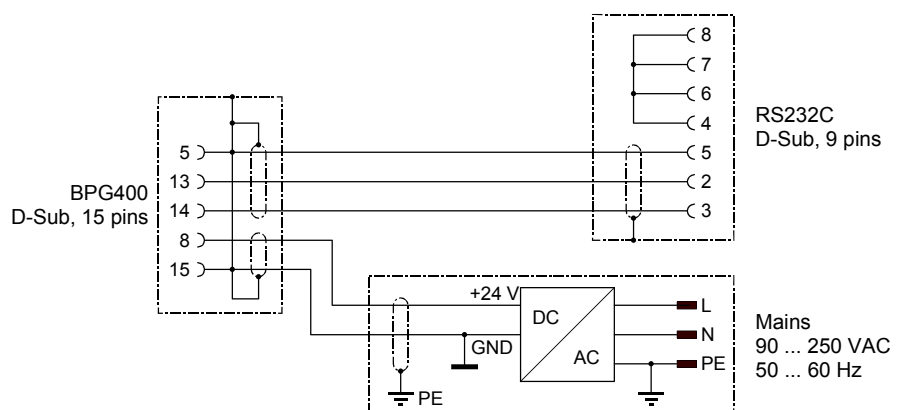

Connecting the power supply

- 1 Connect the gauge to the power supply and lock the connector with the screws.
- 2 Connect the RS232C line to the instrument or control device and lock the connector with the screws.

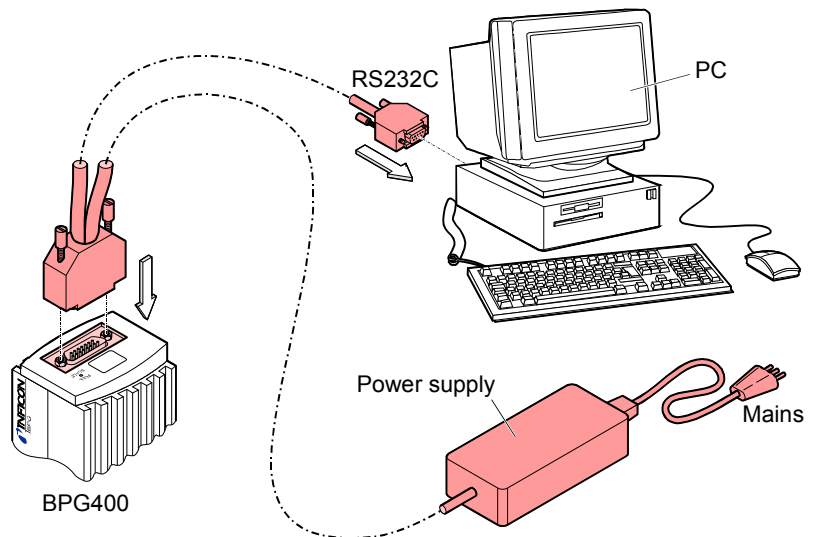

- 3 Connect the power supply to the mains.
 - 4 Turn the power supply on.
- ✓ The gauge can now be operated via RS232C interface (→ 31).

4 Operation

4.1 Measuring Principle, Measuring Behavior

Bayard-Alpert

The BPG400 vacuum gauges consist of two separate measuring systems (hot cathode Bayard-Alpert (BA) and Pirani).

The BA measuring system uses an electrode system according to Bayard-Alpert which is designed for a low x-ray limit.

The measuring principle of this measuring system is based on gas ionization. Electrons emitted by the hot cathode (F) ionize a number of molecules proportional to the pressure in the measuring chamber. The ion collector (IC) collects the thus generated ion current I^+ and feeds it to the electrometer amplifier of the measurement instrument. The ion current is dependent upon the emission current I_e , the gas type, and the gas pressure p according to the following relationship:

$$I^+ = I_e \times p \times C$$

Factor C represents the sensitivity of the gauge head. It is generally specified for N_2 .

The lower measurement limit is 5×10^{-10} mbar (gauge metal sealed).

To usefully cover the whole range of 5×10^{-10} mbar ... 10^{-2} mbar, a low emission current is used in the high pressure range (fine vacuum) and a high emission current is used in the low pressure range (high vacuum). The switching of the emission current takes place at decreasing pressure at approx. 7.2×10^{-6} mbar, at increasing pressure at approx. 3.2×10^{-5} mbar. At the switching threshold, the BPG400 can temporarily (<2 s) deviate from the specified accuracy.

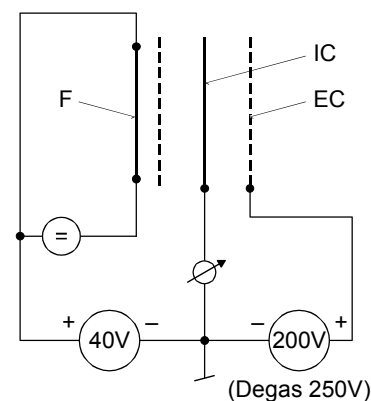
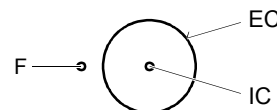

Diagram of the BA measuring system

- F hot cathode (filament)
- IC ion collector
- EC anode (electron collector)



Pirani

Within certain limits, the thermal conductivity of gases is pressure dependent. This physical phenomenon is used for pressure measurement in the thermal conductance vacuum meter according to Pirani. A self-adjusting bridge is used as measuring circuit (→ schematic). A thin tungsten wire forms the sensor element. Wire resistance and thus temperature are kept constant through a suitable control circuit. The electric power supplied to the wire is a measure for the thermal conductance and thus the gas pressure. The basic principle of the self-adjusting bridge circuit is shown in the following schematic.

Schematic

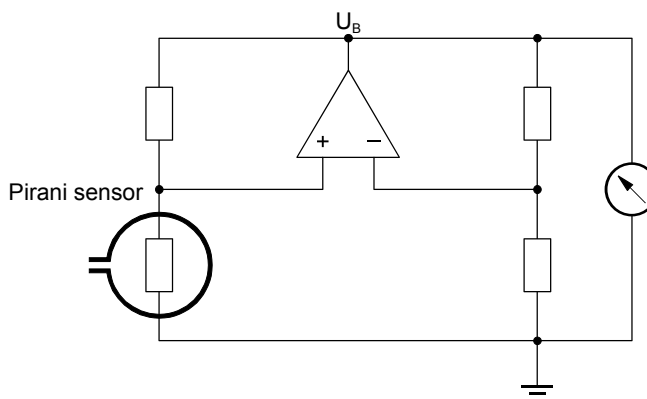

The bridge voltage U_B is a measure for the gas pressure and is further processed electronically (linearization, conversion).

Measuring range

The BPG400 gauges continuously cover the measuring range 5×10^{-10} mbar ... 1000 mbar.

- The Pirani constantly monitors the pressure.
- The hot cathode (controlled by the Pirani) is activated only at pressures $< 2.4 \times 10^{-2}$ mbar.

If the measured pressure is higher than the switching threshold, the hot cathode is switched off and the Pirani measurement value is output.

If the Pirani measurement drops below the switching threshold ($p = 2.4 \times 10^{-2}$ mbar), the hot cathode is switched on. After heating up, the measured value of the hot cathode is fed to the output. In the overlapping range of 5.5×10^{-3} ... 2.0×10^{-2} mbar, the output signal is generated from both measurements.

Pressure rising over the switching threshold ($p = 3.2 \times 10^{-2}$ mbar) causes the hot cathode to be switched off. The Pirani measurement value is output.

Gas type dependence

The output signal is gas type dependent. The characteristic curves are accurate for dry air, N_2 and O_2 . They can be mathematically converted for other gases (\rightarrow Appendix B).

4.2 Operational Principle of the Gauge

The measuring currents of the Bayard-Alpert and Pirani sensor are converted into a frequency. A micro-controller converts this frequency into a digital value representing the measured total pressure. After further processing this value is available as analog measurement signal (0 ... +10 V) at the output (sensor cable connector Pin 2 and Pin 12). The maximum output signal is internally limited to +10 V (atmosphere). The measured value can be read as digital value through the RS232C interface (Pins 13, 14, 15) (\rightarrow 31). Gauges with a display show the value as pressure. The default setting of the displayed pressure unit is mbar. It can be modified via the RS232C interface (\rightarrow 31).

In addition to converting the output signal, the micro controller's functions include monitoring of the emission, calculation of the total pressure based on the measurements of the two sensors, and communication via RS232C interface.

4.3 Putting the Gauge Into Operation

When the operating voltage is supplied (→ Technical Data), the output signal is available between Pin 2 (+) and Pin 12 (–) of the sensor cable connector (Relationship Output Signal – Pressure → Appendix A).

Allow for a stabilizing time of approx. 10 min. Once the gauge has been switched on, permanently leave it on irrespective of the pressure.

Communication via the digital interfaces is described in separate sections.

4.4 Degas

Contamination



Gauge failures due to contamination are not covered by the warranty.

Deposits on the electrode system of the BA gauge can lead to unstable measurement readings.

The degas process allows in-situ cleaning of the electrode system by heating the electron collector grid to approx. 700 °C by electron bombardment.

Depending on the application, this function can be activated by the system control via one of the gauges digital interfaces. The BPG400 automatically terminates the degas process after 3 minutes, if it has not been stopped before.



The degas process should be run at pressures below 7.2×10^{-6} mbar (emission current 5 mA).

For a repeated degas process, the control signal first has to change from ON (+24 V) to OFF (0 V), to then start degas again with a new ON (+24 V) command. It is recommended that the degas signal be set to OFF again by the system control after 3 minutes of degassing, to achieve an unambiguous operating status.

4.5 Display (BPG400)

The gauges with part number
353-501 and
353-503

have a built-in two-line display with an LCD matrix of 32×16 pixels. The first line shows the pressure, the second line the pressure unit, the function and possible errors. The background illumination is usually green, in the event of an error, it changes to red. The pressure is displayed in mbar (default), Torr or Pa. The pressure unit can be changed via RS232C interface (→ 31).

Pressure display

Pressure reading, pressure unit

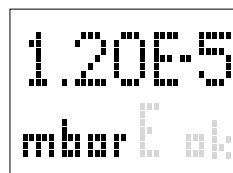

Function display

(none) Pirani operation
E Emission 25 μ A
E. Emission 5 mA
D Degas
R 1000 mbar adjustment (Pirani)

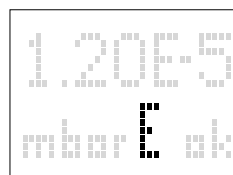

Error display

ak no error
(green background illumination)
5 Pirani sensor warning
(red background illumination)
9 Pirani sensor error
(red background illumination)

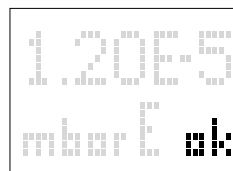

8 BA sensor error
(red background illumination)



Internal data connection failure
(red background illumination)

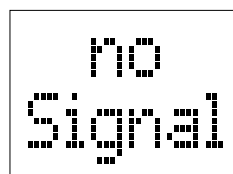

What to do in case of problems → 49.

4.6 RS232C Interface

The built-in RS232C interface allows transmission of digital measurement data and instrument conditions as well as the setting of instrument parameters.

Caution

Caution: data transmission errors
 If the gauge is operated with the RS232C interface and a fieldbus interface at the same time, data transmission errors may occur.
 The gauge must not be operated with the RS232C interface and DeviceNet, Profibus or RS485 at the same time.

4.6.1 Description of the Functions

The interface works in duplex mode. A nine byte string is sent continuously without a request approx. every 20 ms.

Commands are transmitted to the gauge in a five byte input (receive) string.

Operational parameters

- Data rate 9600 Baud set value, no handshake
- Byte 8 data bits
 1 stop bit

Electrical connections

- TxD Pin 13
- RxD Pin 14
- GND Pin 5
(Sensor cable connector)

4.6.1.1 Output String (Transmit)

The complete output string (frame) is nine bytes (byte 0 ... 8). The data string is seven bytes (byte 1 ... 7).

Format of the output string

Byte No	Function	Value	Comment
0	Length of data string	7	(Set value)
1	Page number	5	(For BPG400)
2	Status		→ Status byte
3	Error		→ Error byte
4	Measurement high byte	0 ... 255	→ Calculation of pressure value
5	Measurement low byte	0 ... 255	→ Calculation of pressure value
6	Software version	0 ... 255	→ Software version
7	Sensor type	10	(For BPG400)
8	Check sum	0 ... 255	→ Synchronization

Synchronization

Synchronization of the master is achieved by testing three bytes:

Byte No	Function	Value	Comment
0	Length of data string	7	Set value
1	Page number	5	(For BPG400)
8	Check sum of bytes No 1 ... 7	0 ... 255	Low byte of check sum ¹⁾

¹⁾ High order bytes are ignored in the check sum.

Status byte

Bit 1	Bit 0	Definition
0	0	Emission off
0	1	Emission 25 μ A
1	0	Emission 5 mA
1	1	Degas
Bit 2		Definition
0		1000 mbar adjustment off
1		1000 mbar adjustment on
Bit 3		Definition
0 \leftrightarrow 1		Toggle bit, changes with every string received correctly
Bit 5	Bit 4	Definition
0	0	Current pressure unit mbar
0	1	Current pressure unit Torr
1	0	Current pressure unit Pa
Bit 7	Bit 6	Definition
x	x	Not used

Error byte

Bit 3	Bit 2	Bit 1	Bit 0	Definition
x	x	x	x	Not used
Bit 7	Bit 6	Bit 5	Bit 4	Definition
0	1	0	1	Pirani adjusted poorly
1	0	0	0	BA error
1	0	0	1	Pirani error

Software version

The software version of the gauge can be calculated from the value of byte 6 of the transmitted string according to the following rule:

$$\text{Version No} = \text{Value}_{\text{Byte 6}} / 20$$

(Example: According to the above formula, Value_{Byte 6} of 32 means software version 1.6)

Calculation of the pressure value

The pressure can be calculated from bytes 4 and 5 of the transmitted string. Depending on the currently selected pressure unit (\rightarrow byte 2, bits 4 and 5), the appropriate rule must be applied.

As result, the pressure value results in the usual decimal format.

$$p_{\text{mbar}} = 10^{((\text{high byte} \times 256 + \text{low byte}) / 4000 - 12.5)}$$

$$p_{\text{Torr}} = 10^{((\text{high byte} \times 256 + \text{low byte}) / 4000 - 12.625)}$$

$$p_{\text{Pa}} = 10^{((\text{high byte} \times 256 + \text{low byte}) / 4000 - 10.5)}$$

Example

The example is based on the following output string:

Byte No	0	1	2	3	4	5	6	7	8
Value	7	5	0	0	242	48	20	10	69

The instrument or controller (receiver) interprets this string as follows:

Byte No	Function	Value	Comment
0	Length of data string	7	(Set value)
1	Page number	5	BPG400
2	Status	0	Emission = off Pressure unit = mbar
3	Error	0	No error
4	Measurement		
4	High byte	242	Calculation of the pressure: $p = 10^{((242 \times 256 + 48) / 4000 - 12.5)} = 1000 \text{ mbar}$
5	Low byte	48	
6	Software version	20	Software version = 20 / 20 = 1.0
7	Sensor type	10	BPG400
8	Check sum	69	$5 + 0 + 0 + 242 + 48 + 20 + 10 = 325_{\text{dec}}$ $\rightarrow 0145_{\text{hex}}$ High order byte is ignored \Rightarrow Check sum = 45_{hex} $\rightarrow 69_{\text{dec}}$

4.6.1.2 Input String (Receive)

For transmission of the commands to the gauge, a string (frame) of five bytes is sent (without <CR>). Byte 1 to byte 3 form the data string.

Format of the input string

Byte no	Function	Value	Comment
0	Length of data string	3	(Set value)
1	Data		\rightarrow admissible input strings
2	Data		\rightarrow admissible input strings
3	Data		\rightarrow admissible input strings
4	Check sum (from bytes No 1 ... 3)	0 ... 255	(low byte of sum) ¹⁾

¹⁾ High order bytes are ignored in the check sum.

Admissible input strings

For commands to the gauge, six defined strings are used:

Command	Byte No				
	0	1	2	3	4 ²⁾
Set the unit mbar in the display	3	16	62	0	78
Set the unit Torr in the display	3	16	62	1	79
Set the unit Pa in the display	3	16	62	2	80
Power-failure-safe storage of current unit	3	32	62	62	156
Switch degas on (switches itself off after 3 minutes)	3	16	93	148	1
Switch degas off before 3 minutes	3	16	93	105	214

²⁾ Only low order byte of sum (high order byte is ignored).

4.7 DeviceNet Interface (BPG400-SD)

This interface allows operation of BPG400-SD with part number 353-507 and 353-508

in connection with other devices that are suited for DeviceNet operation. The physical interface and communication firmware of BPG400-SD comply with the DeviceNet standard (→  [4], [6]).

Two adjustable switching functions are integrated in BPG400-SD. The corresponding relay contacts are available at the sensor cable connector (→  8, 21, 44).

The basic sensor and sensor electronics of all BPG400 gauges are identical.

 **Caution**



Caution: data transmission errors

If the gauge is operated via RS232C interface and DeviceNet interface at the same time, data transmission errors may occur.

The gauge must not be operated via RS232C interface and DeviceNet interface at the same time.

4.7.1 Description of the Functions

Via this interface, the following and further data are exchanged in the standardized DeviceNet protocol (→  [1]):

- Pressure reading
- Pressure unit (Torr, mbar, Pa)
- Degas function
- Gauge adjustment
- Status and error messages
- Status of the switching functions

4.7.2 Operating Parameters

As the DeviceNet protocol is highly complex, the parameters and programming of BPG400-SD are described in detail in the separate Communication Protocol (→  [1]).

4.7.2.1 Operating Software

Before the gauge is put into operation, it has to be configured for DeviceNet operation. A configuration tool and the device specific EDS file (Electronic Data Sheet) are required for this purpose. The EDS file can be downloaded via internet (→  [3]).

4.7.2.2 Node Address Setting

For unambiguous identification of the gauge in a DeviceNet environment, a node address is required. The node address setting is made on the gauge or programmed via DeviceNet.

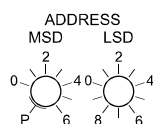

Set the node address (0 ... 63_{dec}) via the "ADDRESS" "MSD" and "LSD" switches. The node address is polled by the firmware when the gauge is switched on. If the setting deviates from the stored value, the new value is taken over into the NVRAM. If a setting higher than 63 is made, the previous node address setting remains valid.

If the „MSD“ switch is in the "P" position, the node address is programmable via DeviceNet (→  [1]).

4.7.2.3 Data Rate Setting

The admissible data rate depends on a number of factors such as system parameters and cable length → [4], [6]). It can be set on the gauge or programmed via DeviceNet.



By means of the "RATE" switch, the data rate can be set to 125 ("1"), 250 ("2") or 500 kBaud ("5").

If the switch is in any of the "P" positions, the data rate is programmable via DeviceNet (→ [1]).

4.7.3 Status Lights

Two lights (LEDs) on the gauge inform on the gauge status and the current DeviceNet status.



"STATUS MOD"
(gauge status):

Light status	Description
Dark	No supply
Flashing red/green	Selftest
Green	Normal operation
Red	Non recoverable error

"STATUS NET"
(network status):

Light status	Description
Dark	Gauge not online: <ul style="list-style-type: none"> – Selftest not yet concluded – No supply, → "STATUS MOD" light
Flashing green	Gauge online but no communication: <ul style="list-style-type: none"> – Selftest concluded but no communication to other nodes established – Gauge not assigned to any master
Green	Gauge online; necessary connections established
Flashing red	One or several input/output connections in "timed out" status
Red	Communication error. The gauge has detected an error that impedes communication via the network (e.g. two identical node addresses (MAC IC) or "Bus-off")

Electrical connections

The gauge is connected to the DeviceNet system via the 5-pin DeviceNet connector (→ 22).

4.8 Profibus Interface (BPG400-SP)

This interface allows operation of BPG400-SP with part number 353-505 and 353-506

in connection with other devices that are suited for Profibus operation. The physical interface and communication firmware of BPG400-SP comply with the Profibus standard (→ [7], [5]).

Two adjustable switching functions are integrated in the BPG400-SP. The corresponding relay contacts are available at the sensor cable connector (→ 8, 21, 44).

The basic sensor and sensor electronics of all BPG400 gauges are identical.

Caution

Caution: data transmission errors
If the gauge is operated via RS232C interface and Profibus interface at the same time, data transmission errors may occur.
The gauge must not be operated via RS232C interface and Profibus interface at the same time.

4.8.1 Description of the Functions

Via this interface, the following and further data are exchanged in the standardized Profibus protocol (→ [2]):

- Pressure reading
- Pressure unit (Torr, mbar, Pa)
- Degas function
- Gauge adjustment
- Status and error messages
- Status of the switching functions

4.8.2 Operating Parameters

As the DeviceNet protocol is highly complex, the parameters and programming of BPG400-SP are described in detail in the separate Communication Protocol (→ [2]).

4.8.2.1 Operating Software

For operating the gauge via Profibus, prior installation of the BPG400 specific GSD file is required on the bus master side. This file can be downloaded via internet (→ [3]).

4.8.2.2 Node Address Setting

For unambiguous identification of the gauge in a Profibus environment, a node address is required. The node address setting is made on the gauge.

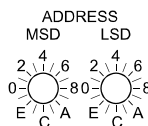

The node address (0 ... 125_{dec}) is set in hexadecimal form (00 ... 7D_{hex}) via the "ADDRESS", "MSD", and "LSD" switches. The node address is polled by the firmware when the gauge is switched on. If the setting deviates from the stored value, the new value is taken over into the NVRAM. If a value >7D_{hex} (>125_{dec}) is entered, the node address setting currently stored in the device remains valid but it can now be defined via Profibus ("Set slave Address", → [2]).

Electrical connections

The gauge is connected to Profibus via the 9-pin Profibus connector (→ 23).

4.9 RS485 Interface (BPG400-SR)

This interface allows operation of BPG400-SR with part number 353-509 and 353-513

in connection with other devices that are suited for RS485 bus operation.

Two adjustable switching functions are integrated in BPG400-SR. The corresponding relay contacts are available on the sensor cable connector (→ 21).

Additionally, the relay contact of the switching function A is accessible on the RS485 interface connector (→ 24).

The basic sensor and sensor electronics of all BPG400 gauges are identical.



Caution



Caution: data transmission errors
 If the gauge is operated via RS485 and RS232C interface at the same time, data transmission errors may occur.
 The gauge must not be operated via RS485 and RS232C interface at the same time.

4.9.1 Description of the Functions and Modes

Via this interface, the following and further data are exchanged between a bus master (host) and the BPG400-SR (device) in the RS485 protocol.

- Pressure reading
- Pressure unit (Torr, mbar, Pa)
- Degas function
- Operation modes
- Status and error messages
- Thresholds of the switching functions

Operation modes of the BPG400-SR

The BPG400-SR can be operated in two operation modes. While the "BPG" mode (default mode) takes full advantage of all the gauges capabilities.

The "RIG" mode has a somewhat reduced scope of parameters (→ 40).

4.9.2 Data Exchange

The controlling host sends its commands to the individually addressed devices connected to the bus. In reply the device returns the data requested via bus to the host.

A maximum of 127 devices can be connected to a RS485 bus system.

4.9.2.1 Operational Parameters

- Data rates: 300, 1200, 2400, 4800, 9600, 19'200 ¹⁾, 28'800 Baud
- Byte: 8 data bits ¹⁾
 1 stop bit ¹⁾
 No parity ¹⁾

¹⁾ Default settings

4.9.2.2 Device Address

For unambiguous identification of the gauge in a RS485 bus environment, a device address is required.

The device address (base address) setting is primarily made on the gauge. Via RS485 communication, an address offset can be added from the host:

Operating device address	=	base address	+	offset
--------------------------	---	--------------	---	--------

where:

Operating device address	00 ... 7F _{hex} ¹⁾	aa (→ 39)	
Base address	00 ... 7F _{hex}	Gauge setting (switches, → below)	
Offset	00 ... 7F _{hex}	From host, oo (→ 39)	

1) Sum of base address and offset must not exceed 7F_{hex}

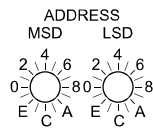

The base address (0 ... 127_{dec}) is set in hexadecimal form (00 ... 7F_{hex}) via the "ADDRESS", "MSD", and "LSD" switches. The address is polled by the firmware when the gauge is switched on only. If the address set by the switches is above the allowed range, all parameters are set to the factory default values. Communication is not possible in this case.

4.9.2.3 Command Structure (Host)

Commands sent by the host must include the following elements:

Element:	Start character	Operating device address (aa)	_ ³⁾	Data ¹⁾	Terminator
Value:	#	00 ... FF _{hex}	Space	→ "commands and responses"	CR ²⁾

- 1) Characters can be upper or lower case.
- 2) Carriage return (0D_{hex} or *ctrl M*)
- 3) A *Space* character is signified by a " " (underline) character in the text.

4.9.2.4 Response Structure

The response message returned by the BPG400-SR has the following structure:

Element:	Start character	Operating device address (aa)	_ ³⁾	Data ¹⁾	Terminator
Value:	*	00 ... FF _{hex}	Space	→ "commands and responses"	CR ²⁾

- 1) Characters returned by the BPG400-SR are always upper case.
- 2) Carriage return (0D_{hex} or *ctrl M*)
- 3) A *Space* character is signified by a " " (underline) character in the text.

4.9.2.5 Error Messages

If an incorrect data string is sent by the host, the BPG400-SR will return an error message with the following structure:

Element:	Start character	Operating device address (aa)	_ ³⁾	Data ¹⁾³⁾	Terminator
Value:	?	00 ... FF _{hex}	Space	ERROR	CR ²⁾

- 1) Characters returned by the BPG400-SR are always upper case.
- 2) Carriage return (0D_{hex} or *Ctrl M*)
- 3) A *Space* character is signified by a " " (underline) character in the text.

4.9.3 Syntax Description

4.9.3.1 Definitions, Legend

In the table "Commands and Responses" (→ 40) the following variables are used:

Variable	Description	Values, range,
<i>aa</i>	Operating device address	00 ... 3F _{hex}
<i>fff</i>	Emission current	<u>25</u> UA = 25 μA 5.0 <u>MA</u> = 5 mA <u>20</u> MA = 20 mA
<i>modeR</i>	Gauge operation mode, response	BPG_400_ = BPG400 mode RIG_ _ _ _ _ = RIG mode (reduced ion gauge mode)
<i>modeT</i>	Gauge operation mode, command	BPG400 = BPG400 mode RIG = RIG mode (reduced ion gauge mode)
<i>n</i>	Filament selected	1 2 No action, for future use
<i>oo</i>	Address offset	00 ... 3F _{hex}
<i>rate</i>	Data transfer rate	300, 1200, 2400, 4800, 9600, 19'200 or 28'800 Baud
<i>status</i>	Gauge status	BPG mode: BPG_ST_0 = no error BPG_ST_5 = Pirani warning BPG_ST_8 = BA error BPG_ST_9 = Pirani error RIG mode: 01_OVPRS If emission is switched off 02_EMISS = BA error 00_ST_OK = normal operation
<i>t</i>	Toggle status	ON = toggle function on OFF = toggle function off
<i>unit</i>	Pressure unit	MBAR, TORR, PASCAL
<i>v.vv</i>	Firmware version of gauge	Three characters and a decimal point. Higher revision numbers indicate newer versions of firmware. Example: 1.00.
<i>x.xx</i>	Mantissa of pressure values	1.00 ... 9.99
<i>sy</i>	Signed exponent of pressure values	s = Sign of exponent, +/- yy = Exponent 00 ... 09
<i>z</i>	Operation of relays (switching function)	+ = Relay on below threshold - = Relay on above threshold



All Commands and responses are terminated by "carriage return" (CR).

All response messages contain 13 characters, including CR.

For better readability, a space character is signified by a " _ " (underline) character in the table below.

4.9.3.2 Commands and Responses

The following table lists all permissible commands of the RS485 host and the corresponding responses of a BPG400 SR during data transfer.

Depending on the operation mode selected (BPG or RIG mode) the BPG400-SR responses may differ. Syntax errors will produce an error message.

For each command listed, a programming example is given in the last column where:

T: Command data transmitted by the host

R: Data received by the host (from BPG400-SR), in BPG and RIG mode

R_{BPG}: Data received by the host (from BPG400-SR), only in BPG mode

R_{RIG}: Data received by the host (from BPG400-SR), only in RIG mode

Host Command	Host Command syntax	BPG mode Response syntax	RIG mode Response syntax	Programming example and remarks
Read pressure measured value	#aaRD CR	*aa_x.xxEsyy CR	→ BPG mode	T: #02RD CR R: *02_5.36E-04 CR R _{RIG} : *02_9.99E+09 CR If gauge is switched off and during the first 3 seconds after gauge is switched on.
Read status	#aaRS CR	*aa_status CR	→ BPG mode	T: #02RS CR R _{BPG} : *02_BPG_ST_5 CR R _{RIG} : *02_00_ST_OK CR
Set address (offset)	#aaSAoo CR	*aa_PROGM_OK CR	→ BPG mode	T: #02A3 CR R *02_PROGM_OK CR New address becomes effective after power is cycled or a reset command is executed. If the user sets the offset address to a value so that the operating device address would be >0x3F _{Hex} , the offset address is set to "0" by the device itself.
Set pressure unit	#aaSUunit CR	*aa_PROGM_OK CR	<i>Error message</i>	T: #02SUPASCAL CR R _{BPG} : *02_PROGM_OK CR New unit becomes effective after power is cycled or a reset command is executed. R _{RIG} : ?02_SYNTAX_ER CR
Read pressure unit	#aaRU CR	*aa_unit CR	<i>Error message</i>	T: #02RU CR R _{BPG} : *02_PASCAL CR R _{RIG} : ?02_SYNTAX_ER CR
Set filament	#aaSFn CR	For future use	*aa_PROGM_OK CR	T: #02SF2 CR R: *02_PROGM_OK CR
Set overpressure	#aaSOx.xxEsyy CR	For future use	*aa_PROGM_OK CR	T: #02SO5.00E-02 CR R: *02_PROGM_OK CR
Set degas off	#aaDG0 CR	*aa_PROGM_OK CR	→ BPG mode	T: #02DG0 CR R: *02_PROGM_OK CR
Set degas on	#aaDG1 CR	*aa_PROGM_OK CR	→ BPG mode	T: #02DG1 CR R: *02_PROGM_OK CR When the gauge is switched off, a degas on command will produce an error message: R: ?02_COMM_ERR CR If pressure is >7.20E-06 mbar, the degas on command is disabled
Read emission	#aaSES CR	*aa_xxFA_EM CR	→ BPG mode	T: #02SES CR R: *02__20MA_EM CR
Read version	#aaVER CR	*aa_VERv.vv CR	→ BPG mode	T: #02VER CR R: *02_VER_1.04 CR

Table continued on following page

"Commands and Responses" continued:

Host Command	Host Command syntax	BPG mode Response syntax	RIG mode Response syntax	Programming example and remarks
Set + threshold (Setpoint A)	#aaSL+x.xxEsyy CR	*aa_PROGM_OK CR (*aa_zMIN_HYS CR)	→ BPG mode	T: #02SL+1.00E-04 CR R: *02_PROGM_OK CR
Set - threshold (Setpoint A)	#aaSL-x.xxEsyy CR	*aa_PROGM_OK CR (*aa_zMIN_HYS CR)	→ BPG mode	T: #02SL-2.00E-04 CR R: *02_PROGM_OK CR (SL+ ≠ SL-)
Read + threshold (Setpoint A)	#aaRL+x.xxEsyy CR	*aa_PROGM_OK CR	→ BPG mode	T: #02SL+3.00E-04 CR R: *02_PROGM_OK CR
Read - threshold (Setpoint A)	#aaRL-x.xxEsyy CR	*aa_PROGM_OK CR	→ BPG mode	T: #02SL-3.00E-04 CR R: *02_MIN_HYS CR (SL+ = SL-)
Set + threshold (Setpoint B)	#aaSH+x.xxEsyy CR	*aa_PROGM_OK CR (*aa_zMIN_HYS CR)	→ BPG mode	SL+/SL- and SH+/SH- commands define the setpoints of the switching functions and the operation of the corresponding relays (→ 42).
Set - threshold (Setpoint B)	#aaSH-x.xxEsyy CR	*aa_PROGM_OK CR (*aa_zMIN_HYS CR)	→ BPG mode	
Read + threshold (Setpoint B)	#aaRH+x.xxEsyy CR	*aa_PROGM_OK CR	→ BPG mode	
Read - threshold (Setpoint B)	#aaRH-x.xxEsyy CR	*aa_PROGM_OK CR	→ BPG mode	
Read threshold potentiometer (Setpoint A)	#aaGT1 CR	*aa_x.xxEsyy CR	→ BPG mode	T: #02GT1 CR R: *02_3.50E-04 CR
Read threshold potentiometer (Setpoint B)	#aaGT2 CR	*aa_x.xxEsyy CR	→ BPG mode	
Set factory settings (default)	#aaFAC CR	*aa_PROGM_OK CR	→ BPG mode	All communication parameters will be set to default values (default mode: BPG400)
Set data rate *)	#aaSBrate CR	*aa_PROGM_OK CR	→ BPG mode	T: #02SB9600 CR R: *02_PROGM_OK CR New data rate becomes effective after power is cycled or a reset command is executed.
Set parity none *)	#aaSPN CR	*aa_PROGM_OK CR	→ BPG mode	New setting becomes effective after power is cycled or a reset command is executed.
Set parity odd *)	#aaSPO CR	*aa_PROGM_OK CR	→ BPG mode	
Set parity even *)	#aaSPE CR	*aa_PROGM_OK CR	→ BPG mode	
Unlock	#aaUNL CR	*aa_PROGM_OK CR	→ BPG mode	T: #02UNL CR R: *02_PROGM_OK CR Prior to the commands SB, SPN, SPO, SPE, SDM and GDM, a UNL command must be executed. An attempt to execute the listed commands without a UNL command will produce the error message ?02_COM_ERR CR
Toggle unlock	#aaTLU CR	*aa_1_UL_t CR	→ BPG mode	T: #02TLU CR R: *02_1_UL_ON CR T: #02TLU CR R: *02_1_UL_OFF CR The TLU command toggles the UNL function. When TLU is in the ON state, the commands SB, SPN, SPO, SPE, SDM or GDM can be executed after a UNL command has been carried out. An attempt to execute the commands SB, SPN, SPO, SPE or GDM while TLU is in the OFF state, an error message ?02_SYNTAX_ER CR will result.
Reset	#aaRST CR	No response	No response	After a reset command, communication can be reestablished after 3 seconds.
Set device mode *)	#aaSDMmodeT CR	*aa_PROGM_OK CR	→ BPG mode	T: #02SDM_RIG CR R: *02_PROGM_OK CR
Get device mode *)	#aaGDM CR	*aa_modeR CR	→ BPG mode	T: #02GDM CR R: *02_BPG_400_ CR

*) To prevent accidental changes of these parameters, a TLU - UNL sequence has to be executed prior to the SB, SPN, SPO, SPE, SDM and GDM commands (→ "Toggle unlock" and "Toggle" commands).

4.9.4 Switching Functions

The BPG400-SR has two independent switching functions. A floating relay contact is available for each switching function (→ 21). Additionally, the relay contact of the switching function A is accessible on the RS485 interface connector (→ 24).



The functionality of the switching functions (setting of thresholds and relay operation) depends on the gauges threshold potentiometer settings:

Selecting the Source of the Threshold Values

Threshold potentiometer setting	Functionality of switching function
≤ 0.5 Volt ¹⁾	<ul style="list-style-type: none"> • Thresholds defined by stored values (SL+/-, SH+/-, sent by the host) • Hysteresis defined by independent setting of "+" and "-" values • Relay operation defined by "+" and "-" values and sequential order of data transfer (→ following table)
> 0.5 Volt ¹⁾	<ul style="list-style-type: none"> • Thresholds defined by potentiometer settings • Hysteresis = 10% of threshold • Relays energize when pressure falls below threshold (Same as BPG400-SD/SP, → 44)

¹⁾ Threshold voltages can be read by the host using the appropriate commands (→ 41) or measured on the corresponding pins of the gauges 25 pin D-Sub connector (→ 21).

4.9.4.1 Programming the Switching Functions

The programming procedure of the switching functions via the RS485 interface implemented in the BPG400-SR differs from the one used on BPG400-SD/SP.

The table below describes the programming possibilities.

Function	Threshold values, relay operation	Programming example (→ table, 40)
	$SL+ < SL-$ \Rightarrow relay on below $SL+$	T: #02SL+1.00E-04 CR R: *02_PROGM_OK CR T: #02SL-2.00E-04 CR R: *02_PROGM_OK CR
	$SL+ > SL-$ \Rightarrow relay off below $SL-$	T: #02SL+2.00E-04 CR R: *02_PROGM_OK CR T: #02SL-1.00E-04 CR R: *02_PROGM_OK CR
	$SL- = SL+$, $SL+$ command sent last \Rightarrow relay off below $SL+/SL-$ (minimal hysteresis)	T: #02SL-3.00E-04 CR R: *02_PROGM_OK CR T: #02SL+3.00E-04 CR R: *02+_MIN_HYS CR
	$SL+ = SL-$, $SL-$ command sent last \Rightarrow relay on below $SL+/SL-$ (minimal hysteresis)	T: #02SL+3.00E-04 CR R: *02_PROGM_OK CR T: #02SL-3.00E-04 CR R: *02_-MIN_HYS CR



Programming the second switching function (setpoint B) is identical to the procedure described above. Threshold variables are SH+ and SH- in this case.

4.10 Switching Functions (BPG400-SD, -SP, -SR)

The gauges BPG400-SD, BPG400-SP and BPG400-SR have two independent, manually settable switching functions. Each switching function has a floating normally open relay contact. The relay contacts are accessible at the sensor cable connector (→ 21).

On the BPG400-SR, the change over relay contact of setpoint A is also accessible at the RS485 interface connector (→ 24).

The threshold values of switching functions A and B can be set within the pressure range 1×10^{-9} mbar ... 100 mbar via potentiometers "SETPOINT A" and "SETPOINT B".



The Formula applied to calculate the corresponding threshold voltage $U_{\text{Threshold}}$ depends on the gauge version used.

For BPG400-SD, -SR :

$$U_{\text{Threshold}} = 0.75 \times (\log p_{\text{Setpoint}} - c) + 7.75$$

For BPG400-SP:

$$U_{\text{Threshold}} = 0.8129401 \times (\log p_{\text{Setpoint}} - c + 9.30102999)$$

Constant c is pressure unit dependent (→ Appendix A).

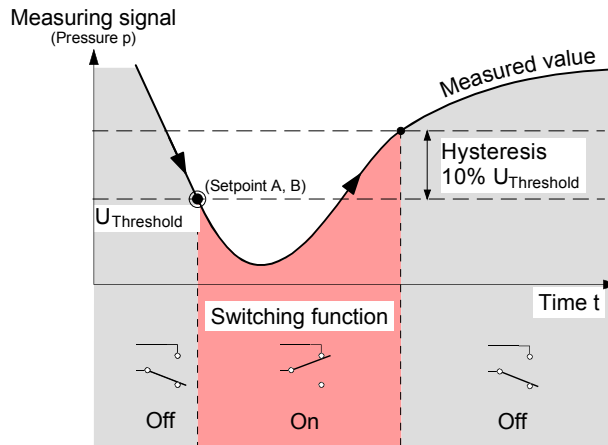

The hysteresis of the switching functions is 10% of the threshold setting.

4.10.1 Setting the Switching Functions

The threshold values of the two switching functions "SETPOINT A" and "SETPOINT B" are set locally on the potentiometers of the gauge that are accessible via the openings on one side of the gauge housing.

Required tools

- Voltmeter
- Ohmmeter or continuity checker
- Screwdriver, max. $\varnothing 2.5$ mm

Procedure

The procedure for setting thresholds is identical for both switching functions.

- ❶ Put the gauge into operation.
- ❷ Connect the + lead of a voltmeter to the threshold measurement point of the selected switching function ("Setpoint A" Pin 3, "Setpoint B" Pin 6) and its – lead to Pin 5.

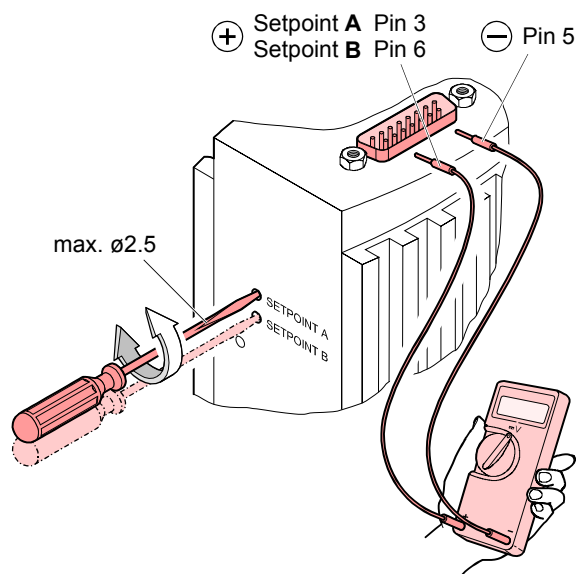

- ❸ Using a screwdriver (max. $\varnothing 2.5$ mm), set the voltage of the selected switching function (Setpoint A, B) to the desired value $U_{\text{Threshold}}$.



On the BPG400-SR, threshold potentiometer settings ≤ 0.5 V are ignored, threshold values defined via RS485 will be effective instead (\rightarrow [42](#)).



Setting of the switching functions is now concluded.



There is no local visual indication of the statuses of the switching functions. However, a functional check of the switching functions (On/Off) can be made with one of the following methods:

- Reading the status via fieldbus interface \rightarrow [1](#) for BPG400-SD, \rightarrow [2](#) for BPG400-SP, \rightarrow [41](#) for BPG400-SR.
- Measurement of the relay contacts at the sensor cable connector with a ohmmeter/continuity checker (\rightarrow [21](#)).

5 Deinstallation

DANGER



Caution: contaminated parts

Contaminated parts can be detrimental to health and environment.

Before beginning to work, find out whether any parts are contaminated. Adhere to the relevant regulations and take the necessary precautions when handling contaminated parts.

Caution



Caution: vacuum component

Dirt and damages impair the function of the vacuum component.

When handling vacuum components, take appropriate measures to ensure cleanliness and prevent damages.

Procedure

- 1 Vent the vacuum system.



Before taking the gauge out of operation, make sure that this has no adverse effect on the vacuum system.

Depending on the programming of the superset controller, faults may occur or error messages may be triggered.

Follow the appropriate shut-down and starting procedures.

- 2 Take gauge out of operation.
- 3 Disconnect all cables from the gauge.
- 4 Remove gauge from the vacuum system and replace the protective lid.

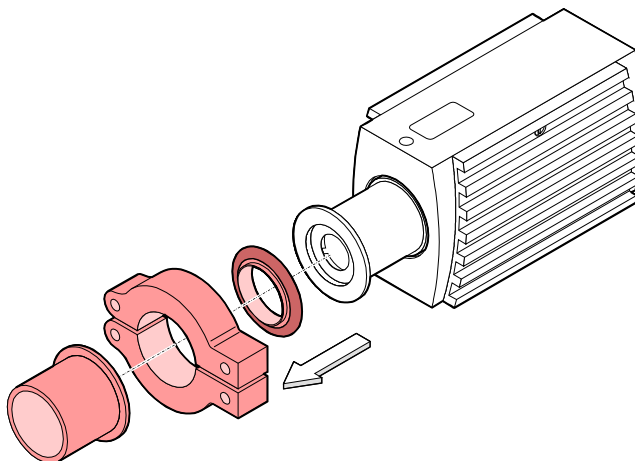

The gauge is now deinstalled.

6 Maintenance, Repair

6.1 Maintenance



DANGER

Caution: contaminated parts

Contaminated parts can be detrimental to health and environment.

Before beginning to work, find out whether any parts are contaminated. Adhere to the relevant regulations and take the necessary precautions when handling contaminated parts.

6.1.1 Cleaning the Gauge

Small deposits on the electrode system can be removed by baking the anode (Degas → 29). In the case of severe contamination, the baffle can be exchanged easily (→ 17). The sensor itself cannot be cleaned and needs to be replaced in case of severe contamination (→ 51).

A slightly damp cloth normally suffices for cleaning the outside of the unit. Do not use any aggressive or scouring cleaning agents.



Make sure that no liquid can penetrate the product. Allow the product to dry thoroughly before putting it into operation again.



Gauge failures due to contamination are not covered by the warranty.

6.2 Adjusting the Gauge

The gauge is factory-calibrated. Through the use in different climatic conditions, fitting positions, aging or contamination (→ 29) and after exchanging the sensor (→ 51) a shifting of the characteristic curve can occur and readjustment can become necessary. Only the Pirani part can be adjusted.

6.2.1 Adjustment at Atmospheric Pressure

At the push of a button the digital value and thus the analog output are adjusted electronically to 10 V at atmospheric pressure.

Adjustment is necessary if

- at atmospheric pressure, the output signal is <10 V
- the display reads < atmospheric pressure (if the gauge has a display)
- at atmosphere, the digital value of the RS232C interface is < atmospheric pressure
- at atmosphere, the digital value received by the bus controller of the fieldbus gauges (DeviceNet, Profibus or RS485) is < atmospheric pressure
- when the vacuum system is vented, the output voltage reaches 10 V (limited to 10 V by the software) before the measured pressure has reached atmosphere (gauges with display will show the error "5" at atmospheric pressure (Pirani sensor warning → 30))
- when the vacuum system is vented, the digital value of the RS232C interface reaches its maximum before the measured pressure has reached atmosphere
- when the vacuum system is vented, the digital value received by the bus controller of the fieldbus (DeviceNet, Profibus or RS485) reaches its maximum before the measured pressure has reached atmosphere.

Required tools

- Pin approx. $\varnothing 1.3 \times 50$ mm (e.g. a bent open paper clip)

Procedure

Gauges BPG400-SD, -SP and -SR are mechanically slightly different from the BPG400. The adjustment opening of BPG400-SD, -SP and -SR is on one side of the gauge housing. However, the adjustment procedure is the same for all gauge versions.

- 1 Operate gauge for approx. 10 minutes at atmospheric pressure.



If the gauge was operated before in the BA range, a cooling-down time of approx. 30 minutes is to be expected (gauge temperature = ambient temperature).

- 2 Insert the pin through the opening and push the button inside for at least 5 s.

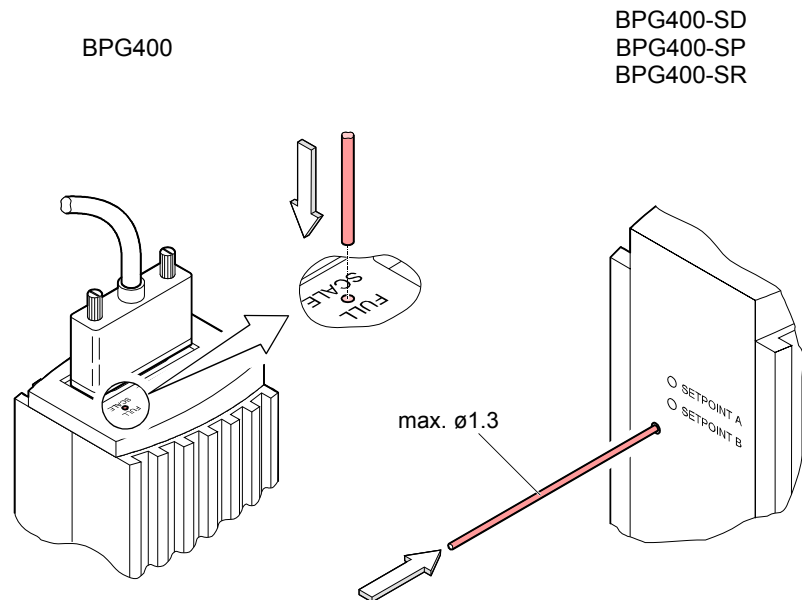

Gauges with display will show the reading "1000 mbar" and the function "A" when the button has been pushed for 4 s. Upon completion of the adjustment, the function indication "A" disappears.



The gauge is automatically adjusted (≈ 10 s).



The gauge is now adjusted at atmospheric pressure.

6.2.2 Zero Point Adjustment

A zero point adjustment is recommended

- after the sensor has been exchanged
- if display shows "FAIL 5" (\rightarrow 30)
- as part of the usual maintenance work for quality assurance

Required tools

- Pin approx. $\varnothing 1.3 \times 50$ mm (e.g. a bent open paper clip)

Procedure

The push button used for the adjustment at atmospheric pressure is also used for the zero point adjustment (→ 47).

- Operate gauge for approx. 10 minutes at a pressure of $\leq 1 \times 10^{-4}$ mbar.
 - Insert the pin through the opening and push the button inside for at least 2 s.
- The adjustment is done automatically and ends after 2 minutes.
- The zero point of the gauge is now adjusted.

6.3 What to Do in Case of Problems

Required tools / material

In the event of a fault or a complete failure of the output signal, the gauge can easily be checked.

- Voltmeter / ohmmeter
- Allen key, size 2.5 mm
- Spare sensor (if the sensor is faulty)

Troubleshooting (BPG400)

The output signal is available at the sensor cable connector (Pin 2 and Pin 12).





In case of an error, it may be helpful to just turn off the mains supply and turn it on again after 5 s.

Problem	Possible cause	Correction
Output signal permanently $\approx 0V$	Sensor cable defective or not correctly connected	Check the sensor cable
	No supply voltage	Turn on the power supply
	Gauge in an undefined status	Turn the gauge off and on again (reset)
Output signal $\approx 0.3 V$ (Display: error = 8)	Hot cathode error (sensor faulty)	Replace the sensor (→ 51)
Output signal $\approx 0.5 V$ (Display: error = 9)	Pirani error (sensor defective)	Replace the sensor (→ 51)
Output signal $\approx 0.5 V$	Electronics unit not mounted correctly on sensor	Check the connection
Display: 	Internal data connection not working	Turn the gauge off and on again after 5 s Replace the electronics unit
Gauge does not switch over to BA at low pressures	Pirani zero point out of tolerance	Carry out a zero point adjustment (→ 48)

Troubleshooting (sensor)

If the cause of a fault is suspected to be in the sensor, the following checks can be made with an ohmmeter (the vacuum system need not be vented for this purpose). Separate the sensor from the electronics unit (→ 14). Using an ohmmeter, make the following measurements on the contact pins.

Ohmmeter measurement between pins			Possible cause
2 + 4	$\approx 37 \Omega$	$\gg 37 \Omega$	Pirani element 1 broken
4 + 5	$\approx 37 \Omega$	$\gg 37 \Omega$	Pirani element 2 broken
6 + 7	$\approx 0.15 \Omega$	$\gg 0.15 \Omega$	Filament of hot cathode broken
4 + 1	∞	$\ll \infty$	Electrode - short circuit to ground
6 + 1	∞	$\ll \infty$	Electrode - short circuit to ground
3 + 1	∞	$\ll \infty$	Electrode - short circuit to ground
9 + 1	∞	$\ll \infty$	Electrode - short circuit to ground
6 + 3	∞	$\ll \infty$	Short circuit between electrodes
9 + 3	∞	$\ll \infty$	Short circuit between electrodes

View on sensor pins

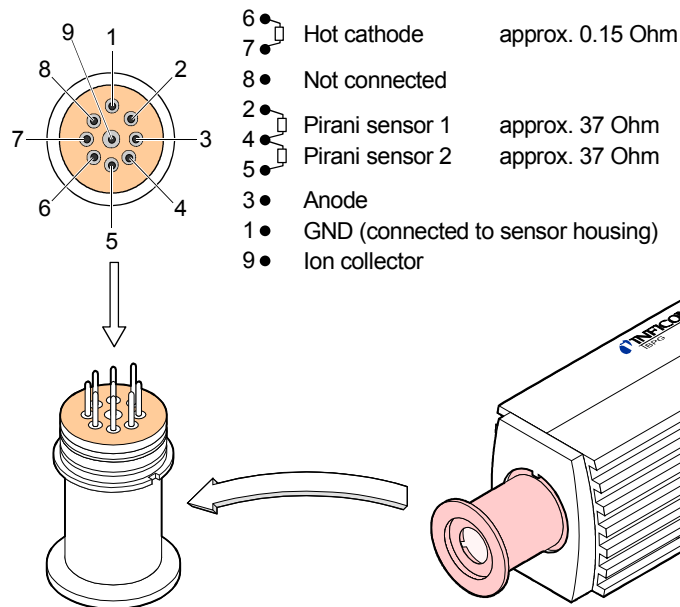

Correction

All of the above faults can only be remedied by replacing the sensor (→ 51).

Troubleshooting on Fieldbus Gauges (BPG400-SD, -SP, -SR)

Error diagnosis of fieldbus gauges can only be performed as described above for the basic sensor and sensor electronics. Diagnosis of the fieldbus interface can only be done via the superset bus controller (→ [1], [2] or 37).

For diagnosis of the BPG400-SD (DeviceNet) gauges, the status lights might produce some useful information (→ 35).

6.4 Replacing the Sensor

Replacement is necessary, when

- the sensor is severely contaminated
- the sensor is mechanically deformed
- the sensor is faulty, e.g. filament of hot cathode broken (→ [49](#))
- the sensor is faulty, e.g. Pirani element broken (→ [49](#))

Required tools / material

- Allen key, size 2.5 mm
- Spare sensor (→ [52](#))

Procedure

- 1** Deinstall the gauge (→ [46](#)).
 - 2** Deinstall the electronics unit from the faulty sensor and mount it to the new sensor (→ [14](#)).
 - 3** Adjust the gauge (→ [47](#)).
-  The new sensor is now installed.

7 Options

	Part number
24 VDC power supply / RS232C line (→ 15 25)	353-511
Extension 100 mm (→ 15 16)	353-510
Baffle DN 25 ISO-KF / DN 40 CF-R (→ 15 17)	353-512

8 Spare Parts

When ordering spare parts, always indicate:

- All information on the product nameplate
- Description and part number

	Part number
Replacement sensor BPG400, vacuum connection DN 25 ISO-KF (including Allen key)	354-490
Replacement sensor BPG400, vacuum connection DN 40 CF-R (including Allen key)	354-491

9 Storage



Caution



Caution: vacuum component

Inappropriate storage leads to an increase of the desorption rate and/or may result in mechanical damage of the product.

Cover the vacuum ports of the product with protective lids or grease free aluminum foil. Do not exceed the admissible storage temperature range (→ 11).

10 Returning the Product

WARNING

Caution: forwarding contaminated products

Contaminated products (e.g. radioactive, toxic, caustic or biological hazard) can be detrimental to health and environment.

Products returned to INFICON should preferably be free of harmful substances. Adhere to the forwarding regulations of all involved countries and forwarding companies and enclose a duly completed declaration of contamination (→ 58).

Products that are not clearly declared as "free of harmful substances" are decontaminated at the expense of the customer.

Products not accompanied by a duly completed declaration of contamination are returned to the sender at his own expense.

11 Disposal

DANGER

Caution: contaminated parts

Contaminated parts can be detrimental to health and environment.

Before beginning to work, find out whether any parts are contaminated. Adhere to the relevant regulations and take the necessary precautions when handling contaminated parts.

WARNING

Caution: substances detrimental to the environment

Products or parts thereof (mechanical and electric components, operating fluids etc.) can be detrimental to the environment.

Dispose of such substances in accordance with the relevant local regulations.

Separating the components

After disassembling the product, separate its components according to the following criteria:

Contaminated components

Contaminated components (radioactive, toxic, caustic or biological hazard etc.) must be decontaminated in accordance with the relevant national regulations, separated according to their materials, and disposed of.

Other components

Such components must be separated according to their materials and recycled.

Appendix

A: Relationship Output Signal – Pressure

Conversion formulae

$$p = 10^{(U - 7.75) / 0.75 + c}$$

$$U = 0.75 \times (\log p - c) + 7.75$$

where

U	p	c
[V]	[mbar]	0
[V]	[Pa]	2
[V]	[Torr]	-0.125

Conversion curve

Pressure p [mbar]

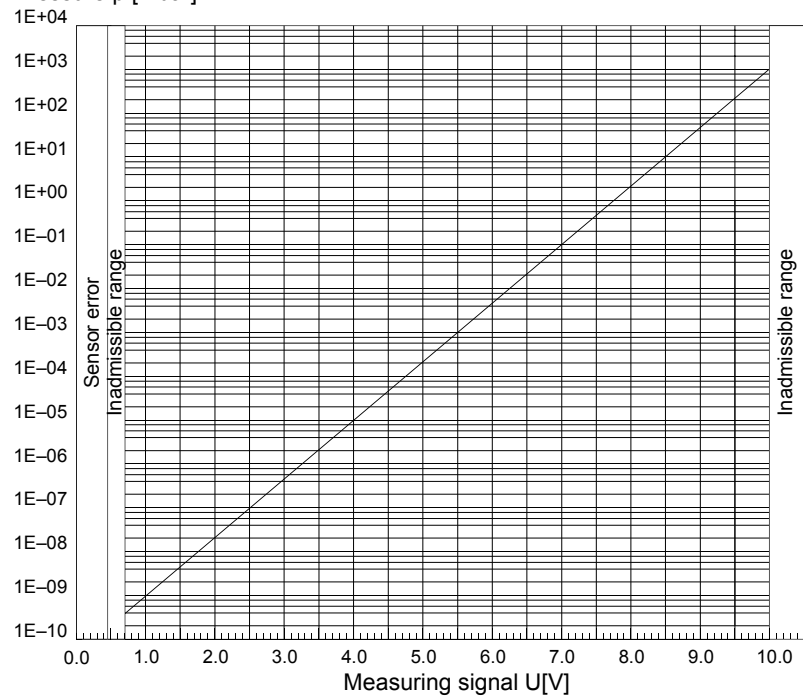

Conversion table

Output signal U [V]	[mbar]	Pressure p [Torr]	[Pa]
0.3 / 0.5		Sensor error (→ 49)	
0.51 ... 0.774		Inadmissible range	
0.774	5×10^{-10}	3.75×10^{-10}	5×10^{-8}
1.00	1×10^{-9}	7.5×10^{-10}	1×10^{-7}
1.75	1×10^{-8}	7.5×10^{-9}	1×10^{-6}
2.5	1×10^{-7}	7.5×10^{-8}	1×10^{-5}
3.25	1×10^{-6}	7.5×10^{-7}	1×10^{-4}
4.00	1×10^{-5}	7.5×10^{-6}	1×10^{-3}
4.75	1×10^{-4}	7.5×10^{-5}	1×10^{-2}
5.50	1×10^{-3}	7.5×10^{-4}	1×10^{-1}
6.25	1×10^{-2}	7.5×10^{-3}	1×10^0
7.00	1×10^{-1}	7.5×10^{-2}	1×10^1
7.75	1×10^0	7.5×10^{-1}	1×10^2
8.50	1×10^1	7.5×10^0	1×10^3
9.25	1×10^2	7.5×10^1	1×10^4
10.00	1×10^3	7.5×10^2	1×10^5
>10.00		Inadmissible range	

B: Gas Type Dependence

Indication range
above 10^{-2} mbar

Pressure indicated (gauge adjusted for air, Pirani-only mode)

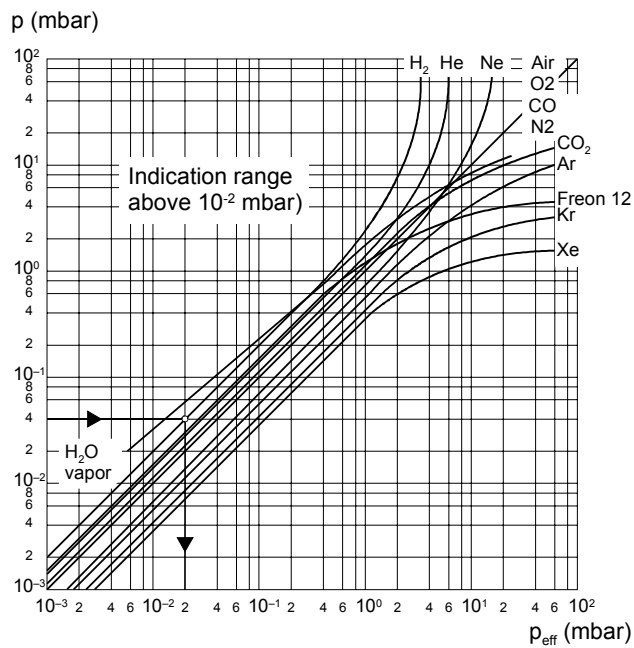

Calibration in pressure range
 10^{-2} ... 1 mbar

The gas type dependence in the pressure range 10^{-2} ... 1 mbar can be compensated by means of the following formula:

$$p_{\text{eff}} = C \times \text{indicated pressure}$$

where	Gas type	Calibration factor C
	Air, O ₂ , CO	1.0
	N ₂	0.9
	CO ₂	0.5
	Water vapor	0.7
	Freon 12	1.0
	H ₂	0.5
	He	0.8
	Ne	1.4
	Ar	1.7
	Kr	2.4
	Xe	3.0

(The above calibration factors are mean values.)

Calibration in pressure range
 $<10^{-3}$ mbar

The gas type dependence in the pressure range $<10^{-3}$ mbar can be compensated by means of the following formula (gauge adjusted for air):

$$p_{\text{eff}} = C \times \text{indicated pressure}$$

where	Gas type	Calibration factor C
	Air, O ₂ , CO, N ₂	1.0
	N ₂	1.0
	He	5.9
	Ne	4.1
	H ₂	2.4
	Ar	0.8
	Kr	0.5
	Xe	0.4

(The above calibration factors are mean values.)



A mixture of gases and vapors is often involved. In this case, accurate determination is only possible with a partial-pressure measuring instrument.

C: Literature

- [1] www.inficon.com
Communication Protocol
DeviceNet™ BPG400-SD
tira03e1
INFICON AG, LI-9496 Balzers, Liechtenstein
- [2] www.inficon.com
Communication Protocol
Profibus BPG400-SP
tira36e1
INFICON AG, LI-9496 Balzers, Liechtenstein
- [3] www.inficon.com
Product descriptions and downloads
INFICON AG, LI-9496 Balzers, Liechtenstein
- [4] www.odva.org
Open DeviceNet Vendor Association, Inc.
DeviceNet™ Specifications
- [5] www.profibus.com
Profibus user organization
- [6] European Standard for DeviceNet EN 50325
- [7] European Standard for Profibus EN 50170
- [8] www.inficon.com
Instruction Sheet
BPG400 (all versions)
tima03e1
INFICON AG, LI-9496 Balzers, Liechtenstein
- [9] www.inficon.com
Instruction Sheet
BPG400-SD, BPG400-SP, BPG400-SR
tima36e1
INFICON AG, LI-9496 Balzers, Liechtenstein
- [10] www.inficon.com
INFICON AG, LI-9496 Balzers, Liechtenstein

Declaration of Contamination

The service, repair, and/or disposal of vacuum equipment and components will only be carried out if a correctly completed declaration has been submitted. Non-completion will result in delay.

This declaration may only be completed (in block letters) and signed by authorized and qualified staff.

1 Description of product

Type _____

Part number _____

Serial number _____

2 Reason for return

3 Operating fluid(s) used (Must be drained before shipping.)

4 Used in copper process

no yes **Seal product in plastic bag and mark it with a corresponding label.**

5 Process related contamination of product:

toxic	no <input type="checkbox"/> 1)	yes <input type="checkbox"/>	 2) Products thus contaminated will not be accepted without written evidence of decontamination.
caustic	no <input type="checkbox"/> 1)	yes <input type="checkbox"/>	
biological hazard	no <input type="checkbox"/>	yes <input type="checkbox"/> 2)	
explosive	no <input type="checkbox"/>	yes <input type="checkbox"/> 2)	
radioactive	no <input type="checkbox"/>	yes <input type="checkbox"/> 2)	
other harmful substances	no <input type="checkbox"/> 1)	yes <input type="checkbox"/>	

The product is free of any substances which are damaging to health. yes

1) or not containing any amount of hazardous residues that exceed the permissible exposure limits

6 Harmful substances, gases and/or by-products

Please list all substances, gases, and by-products which the product may have come into contact with:

Trade/product name	Chemical name (or symbol)	Precautions associated with substance	Action if human contact

7 Legally binding declaration:

We hereby declare that the information on this form is complete and accurate and that we will assume any further costs that may arise. The contaminated product will be dispatched in accordance with the applicable regulations.

Organization/company _____

Address _____ Post code, place _____

Phone _____ Fax _____

Email _____

Name _____

Date and legally binding signature _____ Company stamp _____

Notes

Original: German tina03d1-b (2004-02)



tina03e1-b



LI-9496 Balzers
Liechtenstein
Tel +423 / 388 3111
Fax +423 / 388 3700
reachus@inficon.com

www.inficon.com