



AllCeramic™ CDG025-C

SKY® Capacitance Diaphragm Gauge

All vacuum exposed surfaces of the Sky® AllCeramic™ CDG are constructed of ultra-pure aluminum oxide ceramic, replacing the stainless steel tubing of our traditional CDG. This product is preferred in applications where metal contamination must be avoided.



ADVANTAGES

- No metal contamination
- Marginal zero drift
- Virtually corrosion proof – long sensor life results in reduced downtime thus reducing cost of ownership
- Superior accuracy and repeatability over long period of operation
- Better long term and temperature stability
- Less sensitive to frequent pressure cycles to atmosphere may
- Eliminates isolation valve (depending on operation mode)
- Less susceptible to particles and process by-products due to suprashield
- Fastest warm up time
- Lower cost of investment
- Supply with (+15 VDC or +18.0 to + 26.4 VDC)
- Drop-in replacement of existing CDGs due to interface compatibility

APPLICATIONS

- Etch, CVD and PVD processes
- Doping silicon using implantation or diffusion processes
- Oxidation
- Creation of gate oxide layer in the range of 100 Å
- Creation of barrier layers (Ti, TiN, Ta and TaN as a protection layer between Silicon and Aluminium or Copper)

ORDERING INFORMATION

Type	Flange	Full scale (Pa ¹⁾)				
		133322	13332.2	1333.22	133.322	ATM±13332.2 ²⁾
CDG025-C	1/2" tube	371-250	371-251	371-252	371-253	371-200

¹⁾ Other pressure units on request

²⁾ Pressure difference between atmospheric and gauge pressure

SPECIFICATIONS

Measurement Range F.S. (full scale)	Pa	133322	13332.2	1333.22	133.322	ATM±13332.2
Lowest suggested control pressure	Pa	$6.66 \times 10^{+2}$	$6.66 \times 10^{+1}$	$6.66 \times 10^{+0}$	6.66×10^{-1}	–
Lowest suggested reading	Pa	$6.66 \times 10^{+1}$	$6.66 \times 10^{+0}$	6.66×10^{-1}	6.66×10^{-2}	–
Lowest reading	Pa	$1.33 \times 10^{+1}$	$1.33 \times 10^{+0}$	1.33×10^{-1}	1.33×10^{-2}	–
Accuracy ¹⁾	% of reading	0.2	0.2	0.2	0.2	0.2
Temperature effect on zero	% F.S./°C	0.005	0.005	0.005	0.015	0.05
on span	% of reading/°C	0.01	0.01	0.01	0.01	0.04
Resolution	% F.S.	0.0015	0.0015	0.0015	0.0025	0.01
Temperature Operation (ambient)	°C	+5 ... +50	+5 ... +50	+5 ... +50	+5 ... +50	+5 ... +50
At flange	°C	≤110	≤110	≤110	≤110	≤110
Storage	°C	–40 ... +65	–40 ... +65	–40 ... +65	–40 ... +65	–40 ... +65
Pressure max. (absolute)	kPa	400	267	267	267	267
Power supply Voltage 1 or Voltage 2	VDC	±15 ±5%	±15 ±5%	±15 ±5%	±15 ±5%	±15 ±5%
Power consumption ²⁾	W	≤1.6	≤1.6	≤1.6	≤1.6	≤1.6
Output signal (analog) Measuring range	V	0 ... +10	0 ... +10	0 ... +10	0 ... +10	+5±5
Voltage range	V	–11 ... +11	–11 ... +11	–11 ... +11	–11 ... +11	–11 ... +11
Relation voltage vs. pressure		linear	linear	linear	linear	linear
Response time	ms	30	30	30	100	30
Internal volume	cm ³ (inch ³)	4.5 (0.275)	4.5 (0.275)	4.5 (0.275)	4.5 (0.275)	4.5 (0.275)
Weight	g	250	250	250	250	250
Protective type		IP 30	IP 30	IP 30	IP 30	IP 30
Electrical connection		D-sub, 15 pole, male	D-sub, 15 pole, male	D-sub, 15 pole, male	D-sub, 15 pole, male	D-sub, 15 pole, male
Materials exposed to vacuum		Aluminum oxide ceramic (Al ₂ O ₃), sealing glass				

¹⁾ Non-linearity, hysteresis, repeatability at 25 °C ambient operating temperature without temperature effects after 2 hours operation.

²⁾ Typical value at 25°C ambient temperature after reaching operating temperature.

DIMENSIONS

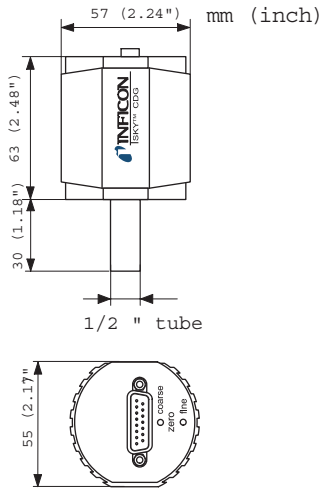

GLOBAL HEADQUARTERS:

Two Technology Place, East Syracuse, NY 13057 USA
Tel: +1.315.434.1100 Fax: +1.315.437.3803 E-mail: reachus@inficon.com

UNITED STATES FRANCE GERMANY LIECHTENSTEIN SWITZERLAND UNITED KINGDOM CHINA JAPAN KOREA SINGAPORE TAIWAN

Visit our website for contact information and other sales offices worldwide. www.inficon.com
Due to our continuing program of product improvements, specifications are subject to change without notice.
tiba07e1-a (2004-06) ©2003 INFICON