

Insert Valve

electromagnetically actuated
normally closed

VAM005-X

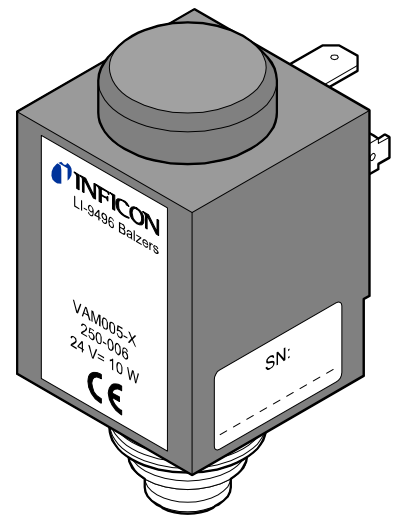

Product Identification

In all communications with INFICON, please specify the information on the product nameplate. For convenient reference copy that information into the space provided below.

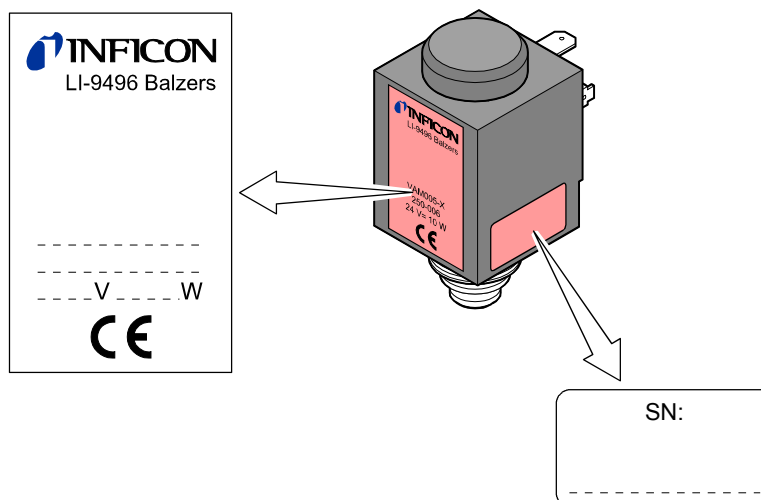

Validity

This document applies for products with part number 250-006.
The part number can be taken from the product nameplate.

We reserve the right to make technical changes without prior notice.

All dimensions in mm.

Intended Use

The VAM005-X is predominantly used in fast-cycling vacuum systems, for example, for gas analysis and coating processes.

Functional Principle

The VAM005-X is opened by a solenoid coil and closed by a prestressed pressure spring.

It will close, or remain closed, in the event of a power failure.

Contents

Product Identification	2
Validity	2
Intended Use	2
Functional Principle	2
1 Safety	4
1.1 Symbols Used	4
1.2 Personnel Qualifications	4
1.3 General Safety Instructions	4
1.4 Liability and Warranty	5
2 Technical Data	6
3 Installation	8
3.1 Vacuum Connection	8
3.2 Electrical Connection	13
4 Operation	14
5 Deinstallation	15
6 Returning the Product	16
7 Disposal	16
Declaration of Contamination	17
Declaration of Conformity	18

1 Safety

1.1 Symbols Used

 **DANGER**

Information on preventing any kind of physical injury.

 **WARNING**

Information on preventing extensive equipment and environmental damage.

 **Caution**

Information on correct handling or use. Disregard can lead to malfunctions or minor equipment damage.

→  See page ...

1.2 Personnel Qualifications

 **Skilled personnel**

All work described in this document may only be carried out by persons who have suitable technical training and the necessary experience or who have been instructed by the end-user of the product.

1.3 General Safety Instructions

- Adhere to the applicable regulations and take the necessary precautions for the process media used.
Consider possible reactions between the materials (→  6) and the process media.
Consider possible reactions of the process media due to the heat generated by the product.
- Adhere to the applicable regulations and take the necessary precautions for all work you are going to do and consider the safety instructions in this document.
- Before beginning to work, find out whether any vacuum components are contaminated. Adhere to the relevant regulations and take the necessary precautions when handling contaminated parts.

Communicate the safety instructions to all other users.

1.4 Liability and Warranty

INFICON assumes no liability and the warranty becomes null and void if the end-user or third parties

- disregard the information in this document
- use the product in a non-conforming manner
- make any kind of interventions (modifications, alterations etc.) on the product
- use the product with accessories not listed in the corresponding product documentation.

The end-user assumes the responsibility in conjunction with the process media used.

2 Technical Data

Version	normally closed
Vacuum connection (valve seat)	M20×1
Electrical connection	AM2 tab according to DIN 43650
Nominal voltage	24 VDC ±10%
Nominal power	10 W
Duty cycle	100% (i.e. continuous duty possible)
Type of protection	IP 65 according to DIN 40 050
Conductance for air molecular flow laminar flow	0.3 l/s 3 l/s
Installation position	any
Switching frequency max.	300 / min ¹⁾
Cycles to first maintenance	≈ 10,000,000 ²⁾
Tightness	1×10 ⁻⁹ mbar l/s
Pressure range	1×10 ⁻⁸ mbar ... 10 bar (absolute)
Pressure difference Δp in closing direction in opening direction	5 bar 1.5 bar
Opens to a pressure difference Δp of	1 bar at 24 VDC
Closing time	7 ms ¹⁾
Opening time	30 ms ¹⁾
Temperatures ambience heat generation bakeout with idle solenoid coil bakeout without solenoid coil	5 °C ³⁾ ... 40 °C 60 °C (after 1¼ hour on continuous duty) 120 °C 150 °C
Materials housing actuator seals	stainless steel 1.4301 stainless steel 1.4105 FPM
Weight	≈173 g

¹⁾ At a pressure difference Δp = 0.

²⁾ Under clean operating conditions.

³⁾ -15 °C, if the environment is free of condensable gases.

Dimensions [mm]

Valve

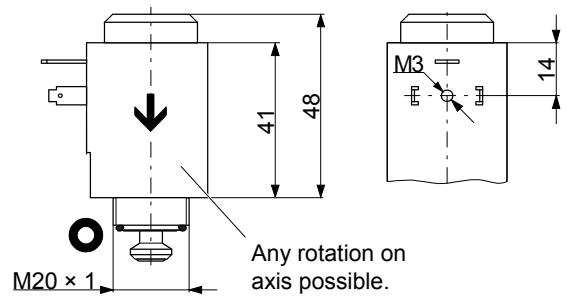

AM2 tabs
DIN 43650

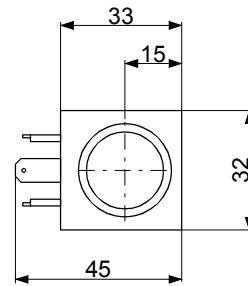

- Flow direction
- Electrical connection
- Protective lid

Valve seat → 8

Space requirements → 9

3 Installation



Skilled personnel



The valve may only be installed by persons who have suitable technical training and the necessary experience or who have been instructed by the end-user of the product.

3.1 Vacuum Connection



Caution



Caution: vacuum component
Dirt and damages impair the function of the vacuum component.
When handling vacuum components, take appropriate measures to ensure cleanliness and prevent damages.



Caution



Caution: dirt sensitive area
Touching the product or parts thereof with bare hands increases the desorption rate.
Always wear clean, lint-free gloves and use clean tools when working in this area.

1

Prepare the valve seat.

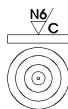
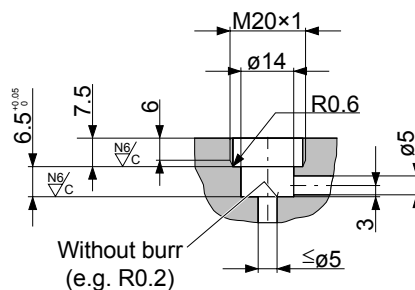

Machining sign:
c = centrally machined, N6 = roughness value $\leq 0.8 \mu\text{m}$

Space requirements

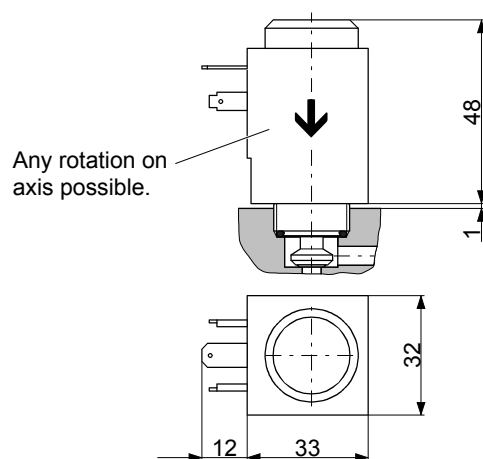

- 2 Remove the protective lid.

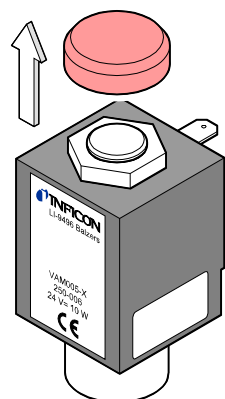

Keep the protective lid.

- 3 Unfasten the nut ...

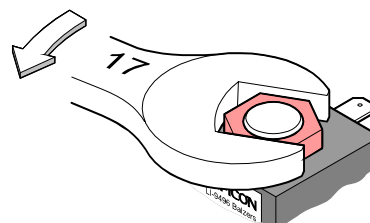

... and remove it with your fingers.

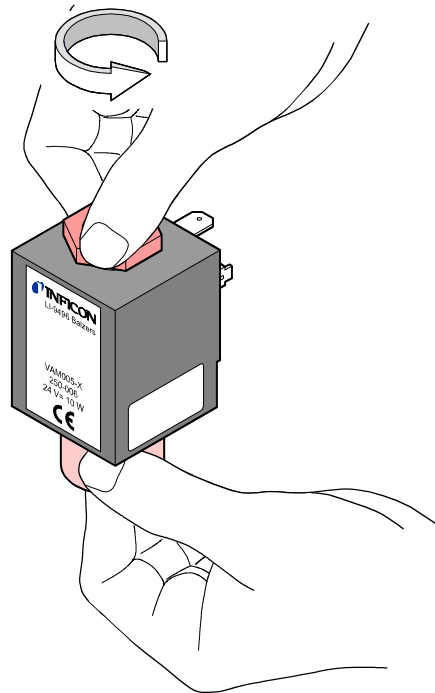

- 4** Deinstall the solenoid coil.

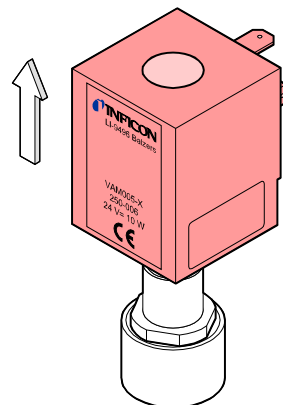

- 5** Remove the protective lid from the guiding tube.



Keep the protective lid.

Caution



Caution: loose parts

The parts (armature, pressure spring and sealing ring) can drop out of the guiding tube and get damaged.

Make sure the parts are correctly positioned.

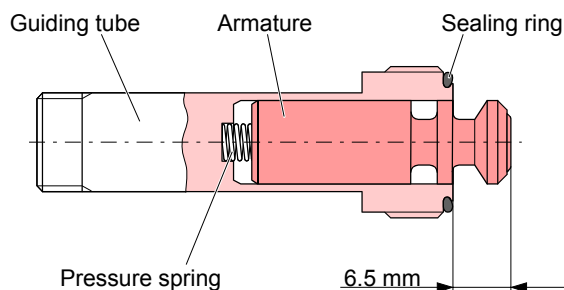

The armature can only be inserted into or removed from the guiding tube in a given position.

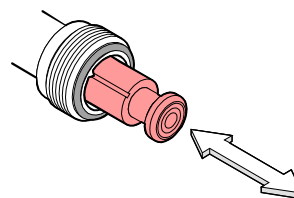

Secure the armature by turning it ($\approx 90^\circ$).

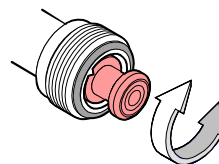

- 6** Screw the guiding tube (with armature, pressure spring and sealing ring) onto the valve seat until the mechanical stop is reached.

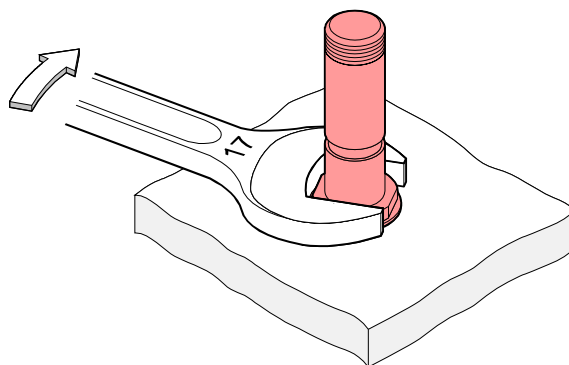

- 7** Slide the solenoid coil onto the guiding tube.

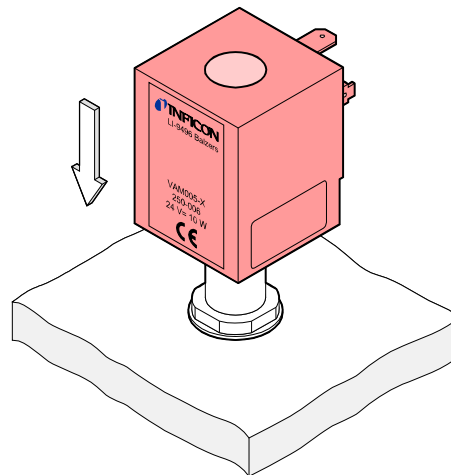

- 8** Reinstall the nut and tighten it with your fingers.

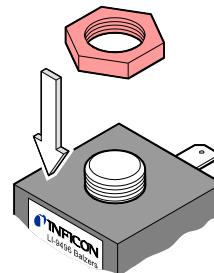

- 9** Turn the solenoid coil so that the electrical connection is in the desired position.

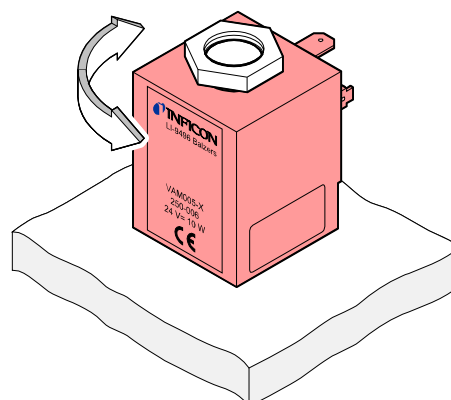

10 Tighten the nut and reinstall the protective lid.

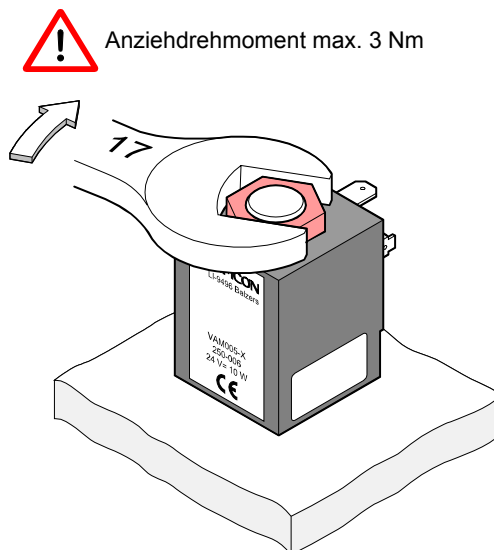

3.2 Electrical Connection

The power is connected via the three tabs. Adhere to the local installation regulations.

Caution

Caution: switching of inductive loads (solenoid coil)
 Inductive loads may considerably reduce the service life of contacts or even destroy them.
 Preferably, a clamping diode should be connected in parallel to the solenoid coil. The polarity should be chosen in such a way that the diode blocks when the normal operating voltage is applied.

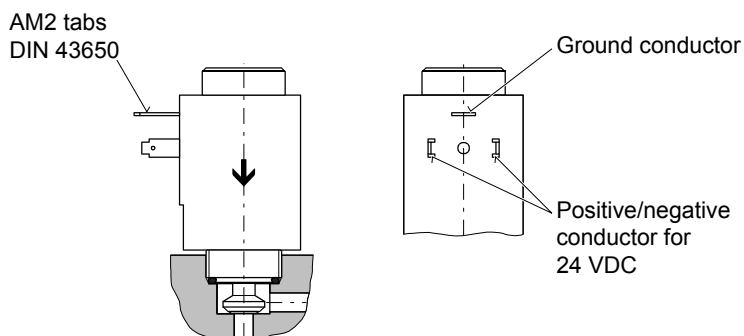

The polarity of the 24 VDC connection need not be taken into consideration.
 For safety reasons, the ground conductor should preferably be connected.

4 Operation

The product is ready for operation as soon as it has been installed.

The VAM005-X will close, or remain closed, in the event of a power failure.

DANGER

Caution: hot surface
 Touching the hot surface (>55 °C) can cause burns.
 Wear protective gloves.

Pressure difference Δp in closing direction

Caution

Caution: pressure difference

At $\Delta p > 5$ bar O-ring at the valve plate can get damage.

Avoid pressure differences $\Delta p > 5$ bar.

Pressure difference Δp in opening direction

Caution

Caution: pressure difference

At $\Delta p > 1.5$ bar the valve is opened.

Avoid pressure differences $\Delta p > 1.5$ bar.

Opening to a pressure difference Δp

Caution

Caution: pressure difference

At $\Delta p > 1$ bar the valve cannot open.

Avoid pressure differences $\Delta p > 1$ bar.

5 Deinstallation

DANGER





Caution: contaminated parts
 Contaminated parts can be detrimental to health and environment.
 Before beginning to work, find out whether any parts are contaminated.
 Adhere to the relevant regulations and take the necessary precautions
 when handling contaminated parts.

Caution



Caution: vacuum component
 Dirt and damages impair the function of the vacuum component.
 When handling vacuum components, take appropriate measures to
 ensure cleanliness and prevent damages.

Caution



Caution: dirt sensitive area
 Touching the product or parts thereof with bare hands increases the
 desorption rate.
 Always wear clean, lint-free gloves and use clean tools when working
 in this area.

Preconditions

- Vacuum system vented
- Control system disconnected from power source
- Valve cooled down to <math>< 55\text{ }^\circ\text{C}</math>

Procedure

- 1** Disconnect the valve from the power and reinstall the protective lid.
- 2** Detach the valve from the vacuum system and reinstall the protective lid.

6 Returning the Product

WARNING

Caution: forwarding contaminated products

Contaminated products (e.g. radioactive, toxic, caustic or biological hazard) can be detrimental to health and environment.

Products returned to INFICON should preferably be free of harmful substances. Adhere to the forwarding regulations of all involved countries and forwarding companies and enclose a duly completed declaration of contamination (→ [17](#)).

Products that are not clearly declared as "free of harmful substances" are decontaminated at the expense of the customer.

Products not accompanied by a duly completed declaration of contamination are returned to the sender at his own expense.

7 Disposal

DANGER

Caution: contaminated parts

Contaminated parts can be detrimental to health and environment.

Before beginning to work, find out whether any parts are contaminated. Adhere to the relevant regulations and take the necessary precautions when handling contaminated parts.

WARNING

Caution: substances detrimental to the environment

Products or parts thereof (mechanical and electric components, operating fluids etc.) can be detrimental to the environment.

Dispose of such substances in accordance with the relevant local regulations.

Separating the components

After disassembling the product, separate its components according to the following criteria:

Contaminated components

Contaminated components (radioactive, toxic, caustic or biological hazard etc.) must be decontaminated in accordance with the relevant national regulations, separated according to their materials, and disposed of.

Other components

Such components must be separated according to their materials and recycled.

Declaration of Conformity



We, INFICON, hereby declare that the product mentioned below complies with the Directive relating to machinery 98/37/EC and the Directive relating to electrical equipment designed for use within certain voltage limits 73/23/EEC.

Product

Insert Valve

electromagnetically actuated
normally closed

VAM005-X

Part numbers

250-006

Standards

Harmonized and international/national standards and specifications:

- EN 292-2 (Safety of machinery)
- EN 60204-1 (Electrical equipment of machines)

Signatures

INFICON AG, Balzers

27 June 2003



Remo Klaiber
Product Marketing Manager

27 June 2003

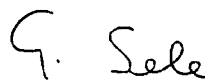

Dr. Georg Sele
Technical Support Manager
Quality Representative

Notes:



srn201e1



*LI-9496 Balzers
Liechtenstein
Tel +423 / 388 3111
Fax +423 / 388 3700
reach.liechtenstein@inficon.com*

www.inficon.com