

Control Valve

VDM005A-X

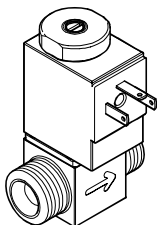

CE

Operating Manual
Incl. Manufacturer's Declaration

Product Identification

In all communications with INFICON please specify the information on the product nameplate. For convenient reference copy that information into the space provided below:

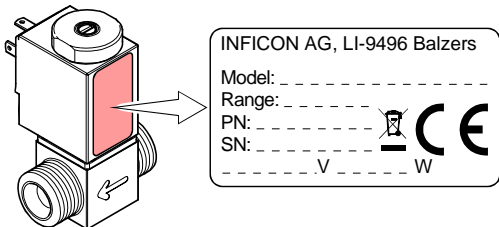

Validity

This document applies to products with part numbers

250-508	(10 sccm)
250-509	(50 sccm)
250-510	(100 sccm)
250-511	(500 sccm)
250-512	(1000 sccm)
250-513	(5000 sccm)

The part number (PN) can be taken from the product nameplate.

We reserve the right to make technical changes without prior notice.

All dimensions in mm.

Intended Use

The VDM005A-X Control Valve is used in conjunction with the VCC500 Controller or another control device for controlling gas flows and thus maintaining a desired pressure in a vacuum system.

It must not be used for controlling liquid gases.

Functional Principle

The VDM005A-X Control Valve opens and closes as a function of the control voltage.

It will close or remain closed in the event of a power loss.

Example of a control loop:

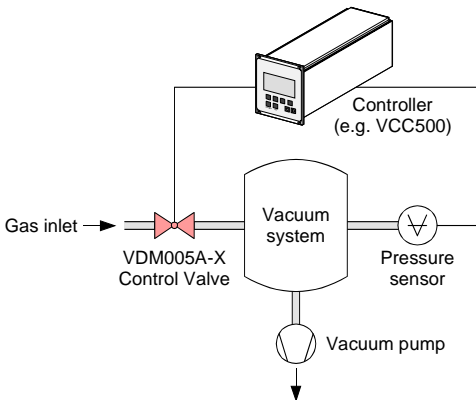

1 Contents

Product Identification	2
Validity	2
Intended Use	3
Functional Principle	3
1 Contents	4
2 Safety	5
2.1 Symbols Used	5
2.2 Personnel Qualifications	5
2.3 General Safety Instructions	6
2.4 Liability and Warranty	6
3 Technical Data	7
4 Installation	10
4.1 Vacuum Connection	10
4.1.1 Flange Connections	11
4.1.2 Tube Connections	13
4.2 Electrical Connection	17
5 Operation	18
6 Deinstallation	18
7 Maintenance / Repair	23
7.1 Replacing the filter	23
8 Accessories	26
9 Returning the Product	27
10 Disposal	28
Declaration of Contamination	29
Manufacturer's Declaration	30

For cross-references within this document, the symbol (→  XY) is used.

2 Safety

2.1 Symbols Used



DANGER

Information on preventing any kind of physical injury.



WARNING

Information on preventing extensive equipment and environmental damage.



Caution

Information on correct handling or use. Disregard can lead to malfunctions or minor equipment damage.

2.2 Personnel Qualifications



Skilled personnel

All work described in this document may only be carried out by persons who have suitable technical training and the necessary experience or who have been instructed by the end-user of the product.

2.3 General Safety Instructions

- Adhere to the applicable regulations and take the necessary precautions for the process media used.
Consider possible reactions between the materials and the process media.
- Adhere to the applicable regulations and take the necessary precautions for all work you are going to do and consider the safety instructions in this document.
- Before beginning to work, find out whether any vacuum components are contaminated. Adhere to the relevant regulations and take the necessary precautions when handling contaminated parts.

Communicate the safety instructions to all other users.

2.4 Liability and Warranty

INFICON assumes no liability and the warranty becomes null and void if the end-user or third parties

- disregard the information in this document
- use the product in a non-conforming manner
- make any kind of interventions (modifications, alterations etc.) on the product
- use the product with accessories not listed in the corresponding product documentation.

The end-user assumes the responsibility in conjunction with the process media used.

3 Technical Data

Vacuum connection	M14x1
Adapters (accessories) flange fitting tube fitting	DN 10 ISO-KF OD ¼", OD 6 mm
Installation angle	any, preferably perpendicular
Pressure range	1×10^{-8} ... 2 bar (absolute)
Tightness	1×10^{-9} mbar l/s
Gas flow ¹⁾ 250-508 250-509 250-510 250-511 250-512 250-513	10 sccm F.S. 50 sccm F.S. 100 sccm F.S. 500 sccm F.S. 1000 sccm F.S. 5000 sccm F.S.
Response time	<30 ms
Supply voltage Control range Power Duty cycle	0 ... 24 VDC 20 ... 70 mA, 1 ... 100% F.S. 2.5 W 100%
Degree of protection	IP51
Temperature Ambiance Bakeout	5 °C ... 50 °C 80 °C (with idle coil)
Materials Housing Armature Guiding tube Springs Seals	stainless steel 1.4301 stainless steel 1.4105 IL stainless steel 1.4305, 1.4105 IL stainless steel 1.4310 FPM
Weight	96 g

1) For air at a pressure difference $\Delta p = 1$ bar

Dimensions [mm]

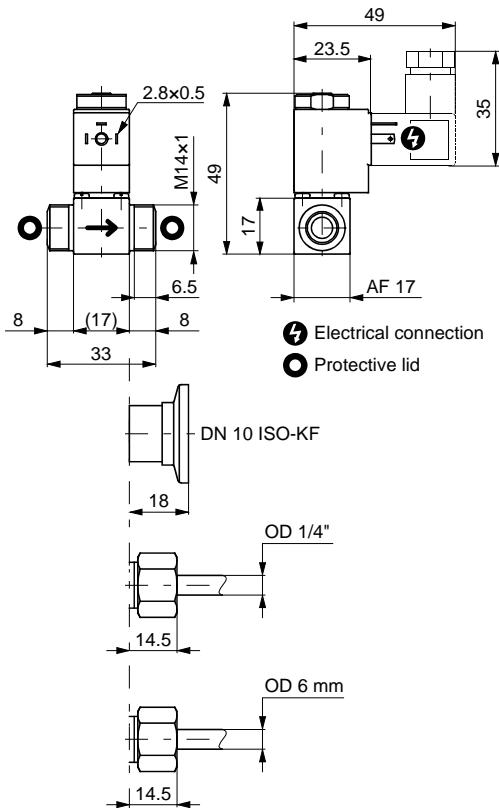

Flow rate curve

Example of a flow rate curve (mean values 500 sccm F.S) at a pressure difference $\Delta p = 1$ bar

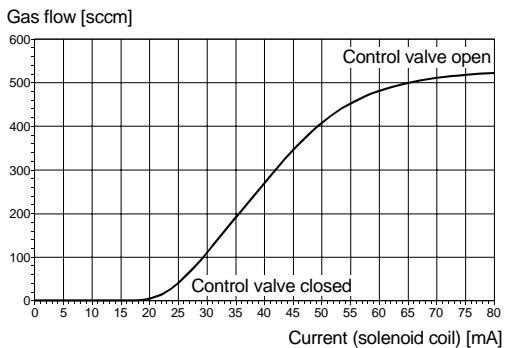

4 Installation

4.1 Vacuum Connection



Caution



Caution: vacuum component

Dirt and damages impair the function of the vacuum component.

When handling vacuum components, take appropriate measures to ensure cleanliness and prevent damages.



Caution



Caution: dirt sensitive area

Touching the product or parts thereof with bare hands increases the desorption rate.

Always wear clean, lint-free gloves and use clean tools when working in this area.

4.1.1 Flange Connections

- 1 Remove the protective lids and mount two flange connections (Accessories → 26).

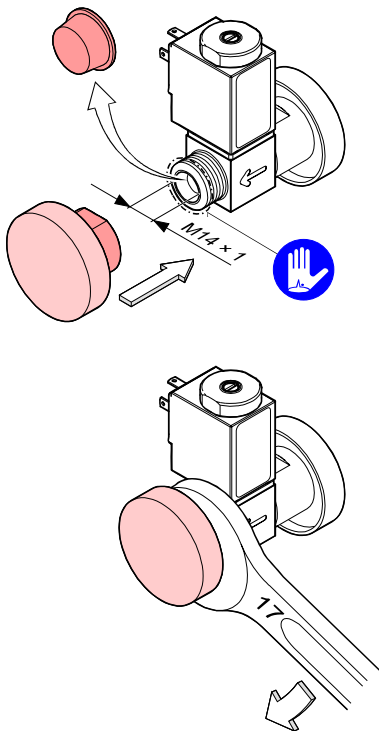

- 2** Remove the protective lids and install the product to the vacuum system.



DANGER



DANGER: overpressure in the vacuum system >1 bar

Injury caused by released parts and harm caused by escaping process gases can result if clamps are opened while the vacuum system is pressurized.

Do not open any clamps while the vacuum system is pressurized. Use the type of clamps which are suited to overpressure.



DANGER



DANGER: overpressure in the vacuum system >2.5 bar

KF flange connections with elastomer seals (e.g. O-rings) cannot withstand such pressures. Process media can thus leak and possibly damage your health.

Use O-rings provided with an outer centering ring.

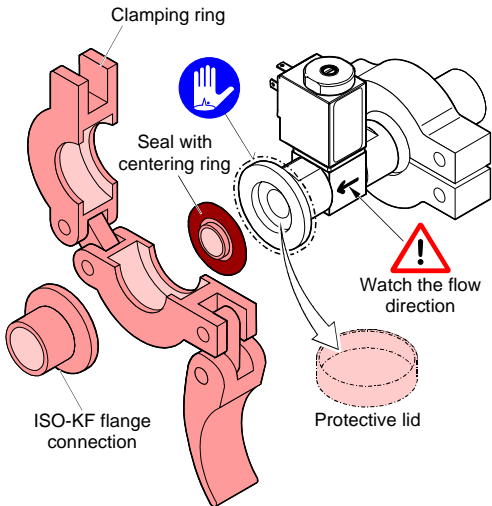

Keep the protective lids.

- 3** Check that the vacuum connections are leak tight.

4.1.2 Tube Connections

- 1** Cut the tube to the required length and remove the burs.

- 2** Slide the union nut and clamping rings over the tube
(Accessories → 26).

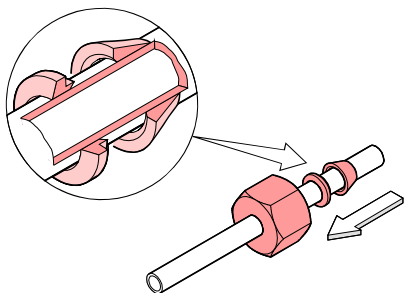

- 3** Remove the protective lid and insert the tube until the mechanical stop is reached.

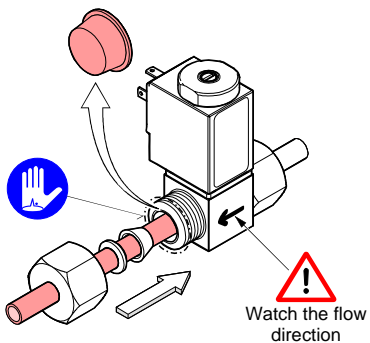

Keep the protective lids.

- 4** Slide the clamping rings up to the mechanical stop.

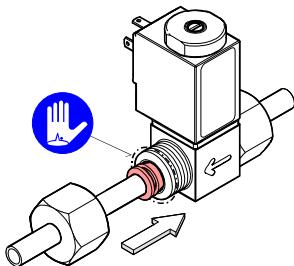

- 5** Tighten the union nut with your fingers.

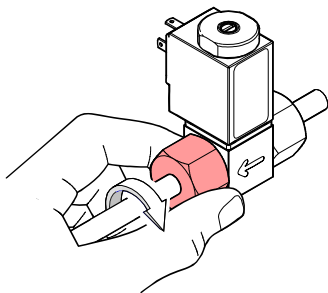

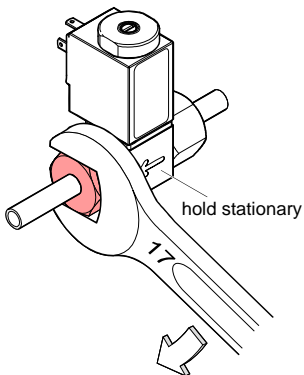

- 6** Tighten the union nut
- initial installation by $\frac{3}{4}$ turns (stainless steel)
 - subsequent installation by $\frac{1}{4}$ turns (stainless steel)



- 7** Check that the vacuum connections are leak tight.

4.2 Electrical Connection

 The polarity of the 24 VDC connection need not be taken into consideration.

 Before connecting or disconnecting the product, turn off the control system.

Pug in the cable socket and secure it with the screw
(Accessories →  26).

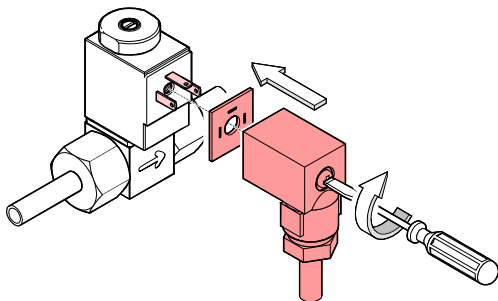

5 Operation

The VDM005A-X Control Valve is ready for operation as soon as it has been installed.

It will close or remain closed in the event of a power loss.

6 Deinstallation

Precondition

Vacuum system vented.



DANGER

DANGER: contaminated parts

Contaminated parts can be detrimental to health and environment.

Before beginning to work, find out whether any parts are contaminated. Adhere to the relevant regulations and take the necessary precautions when handling contaminated parts.



Caution



Caution: vacuum component

Dirt and damages impair the function of the vacuum component.

When handling vacuum components, take appropriate measures to ensure cleanliness and prevent damages.



Caution



Caution: dirt sensitive area

Touching the product or parts thereof with bare hands increases the desorption rate.

Always wear clean, lint-free gloves and use clean tools when working in this area.



Before connecting or disconnecting the product, turn off the control system.

Procedure

- 1 Unfasten the lock screw and unplug the cable socket.

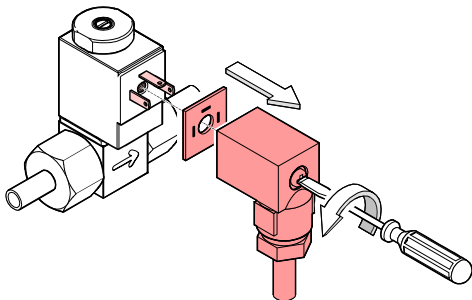

- 2** Remove the product from the vacuum system and place the protective lids.

Flange connections

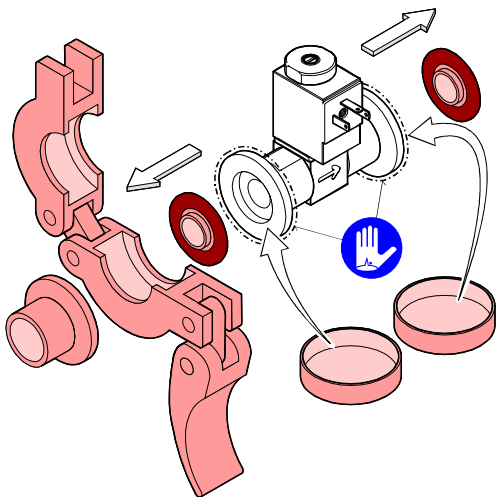

Tube connections

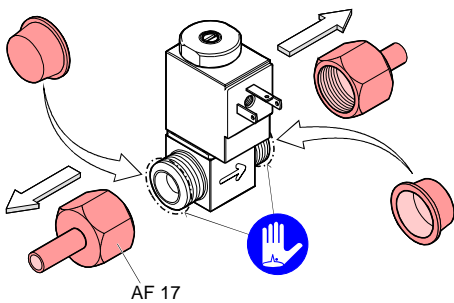

7 Maintenance / Repair

Under clean operating conditions, the product requires no maintenance.

7.1 Replacing the filter

Precondition

Valve deinstalled (Deinsallation →  18).



DANGER

DANGER: contaminated parts

Contaminated parts can be detrimental to health and environment.

Before beginning to work, find out whether any parts are contaminated. Adhere to the relevant regulations and take the necessary precautions when handling contaminated parts.



Caution

Caution: vacuum component

Dirt and damages impair the function of the vacuum component.

When handling vacuum components, take appropriate measures to ensure cleanliness and prevent damages.



Caution



Caution: dirt sensitive area

Touching the product or parts thereof with bare hands increases the desorption rate.

Always wear clean, lint-free gloves and use clean tools when working in this area.

Procedure

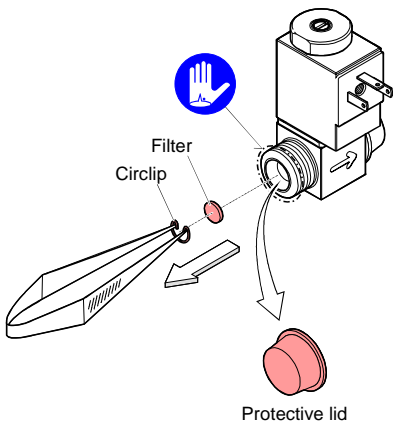

- 1 Remove the filter from the inlet.

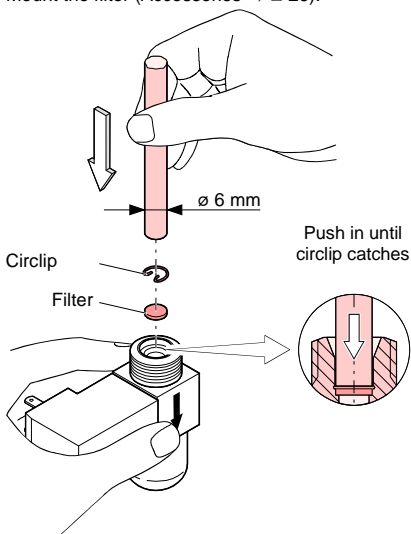

- 2** Mount the filter (Accessories → 26).

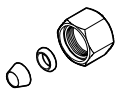
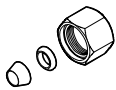
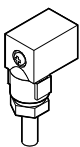

8 Accessories

		Ordering number	
<p>Adapter M14x1</p> <p>1 flange connection DN 10 KF</p>		250-080	
<p>1 tube connection OD ¼"</p>		250-085	
<p>1 tube connection OD 6 mm</p>		250-086	
<p>Connection cable for VCC500 Controller</p>		<p>3 m</p> <p>5 m</p> <p>10 m</p> <p>15 m</p> <p>20 m</p> <p>25 m</p>	<p>250-961</p> <p>250-962</p> <p>250-963</p> <p>250-964</p> <p>250-965</p> <p>250-966</p>
<p>Filter kit, comprising</p> <p>10 polar filter $\varnothing 6 \times 1$</p> <p>10 circlips</p>		215-519	

9 Returning the Product



WARNING



WARNING: forwarding contaminated products
Contaminated products (e.g. radioactive, toxic, caustic or biological hazard) can be detrimental to health and environment.

Products returned to INFICON should preferably be free of harmful substances. Adhere to the forwarding regulations of all involved countries and forwarding companies and enclose a duly completed declaration of contamination.

Products that are not clearly declared as "free of harmful substances" are decontaminated at the expense of the customer. Products not accompanied by a duly completed declaration of contamination are returned to the sender at his own expense.

10 Disposal



DANGER

DANGER: contaminated parts

Contaminated parts can be detrimental to health and environment.

Before beginning to work, find out whether any parts are contaminated. Adhere to the relevant regulations and take the necessary precautions when handling contaminated parts.



WARNING

WARNING: substances detrimental to the environment

Products or parts thereof (mechanical and electric components, operating fluids etc.) can be detrimental to the environment.

Dispose of such substances in accordance with the relevant local regulations.

Separating the components

After disassembling the product, separate its components according to the following criteria:

- Contaminated components
Contaminated components (radioactive, toxic, caustic, microbiological hazard etc.) must be decontaminated in accordance with the relevant national regulations, separated according to their materials, and disposed of.
- Other components
Such components must be separated according to their materials and recycled.

Manufacturer's Declaration

as defined by the Council Directive relating to machinery 98/37/EC, Appendix IIb.



We, INFICON, hereby declare that putting the incomplete equipment mentioned below into operation is not permitted until evidence is given that the system into which that incomplete equipment shall be installed is in conformity with the provisions of the EC Directive relating to machinery.

We also declare that the equipment mentioned below complies with the provisions of the Directive relating to electrical equipment designed for use within certain voltage limits 73/23/EEC.

Control Valve

VDM005A-X

Part numbers

250-508	250-510	250-512
250-509	250-511	250-513

Standards

Harmonized and international/national standards and specifications:

- EN 60730-1 (Automatic electrical controls for household and similar use)
- EN 60730-2-8 (Automatic electrical controls for household and similar use)

Signatures

INFICON AG, Balzers

20 February 2006

A handwritten signature in black ink, appearing to read 'M. Schöch', written in a cursive style.

Michael Schöch
Product Marketing Manager

20 February 2006

A handwritten signature in black ink, appearing to read 'G. Sele', written in a cursive style.

Dr. Georg Sele
Technical Support Manager
Quality Representative



si na96e1



LI-9496 Balzers
Liechtenstein
Tel +423 / 388 3111
Fax +423 / 388 3700
reachus@inficon.com

www.inficon.com