

# Angle Valve

electromagnetically actuated  
normally closed

VVM010-A

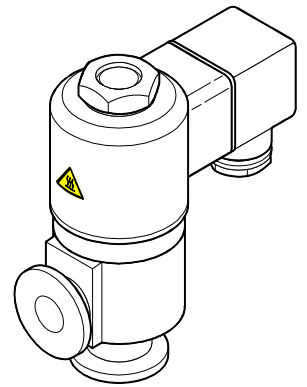

CE

## Product Identification

In all communications with Inficon, please specify the information on the product nameplate. For convenient reference copy that information into the space provided below.

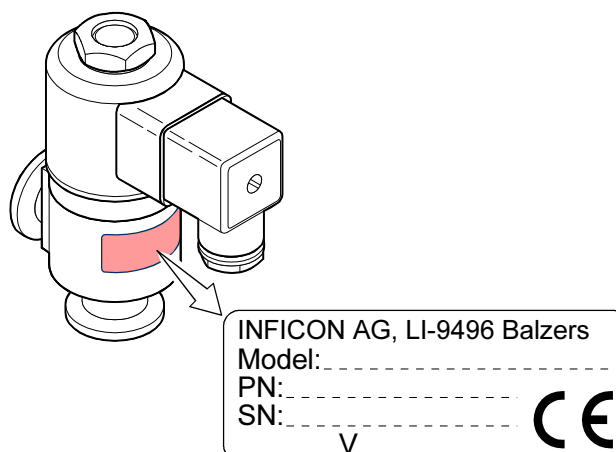

## Validity

This document applies to products with part numbers

250-530	( 24 VDC)
250-531	( 24 VAC)
250-532	(115 VAC)
250-533	(230 VAC)

The part number (No.) can be taken from the product nameplate.

We reserve the right to make technical changes without prior notice.

All dimensions in mm.

## Intended Use

The electromagnetic angle valve VVM010-A can be used in the medium and high vacuum ranges as a shut-off or venting valve.

If the product is to be integrated in a vacuum system where toxic process gases are used or toxic gases arise during the process and where the overpressure can rise to >1 bar, take appropriate safety measures for educating the exhaust gases and dispose of them without polluting the environment.

## Functional Principle

This angle valve is opened by a solenoid coil screwed directly to the valve body and opened by the action of a prestressed spring. It closes automatically in the event of a power failure.

# Contents

Product Identification	2
Validity	2
Intended Use	2
Functional Principle	2
<b>1 Safety</b>	<b>4</b>
1.1 Symbols Used	4
1.2 Personnel Qualifications	4
1.3 General Safety Instructions	4
1.4 Liability and Warranty	4
<b>2 Technical Data</b>	<b>5</b>
<b>3 Installation</b>	<b>7</b>
3.1 Supply Voltage	7
3.2 Vacuum Connection	7
3.3 Power Connection	9
<b>4 Operation</b>	<b>13</b>
<b>5 Deinstallation</b>	<b>14</b>
5.1 Electrical Connection	14
5.2 Vacuum Connection	14
<b>6 Maintenance / Repair</b>	<b>16</b>
6.1 Replacing / Cleaning the Filter	16
6.2 Cleaning the Valve / Replacing Parts	17
<b>7 Accessories</b>	<b>22</b>
<b>8 Spare Parts</b>	<b>23</b>
<b>9 Storage</b>	<b>24</b>
<b>10 Returning the Product</b>	<b>24</b>
<b>11 Disposal</b>	<b>25</b>
<b>Declaration of Contamination</b>	<b>26</b>

For cross-references within this document, the symbol (→  XY) is used.

# 1 Safety

## 1.1 Symbols Used

 **DANGER**

Information on preventing any kind of physical injury.

 **WARNING**

Information on preventing extensive equipment and environmental damage.

 **Caution**

Information on correct handling or use. Disregard can lead to malfunctions or minor equipment damage.

## 1.2 Personnel Qualifications

 **Skilled personnel**

All work described in this document may only be carried out by persons who have suitable technical training and the necessary experience or who have been instructed by the end-user of the product.

## 1.3 General Safety Instructions

- Adhere to the applicable regulations and take the necessary precautions for the process media used.  
Consider possible reactions between the materials (→ 5) and the process media.  
Consider possible reactions of the process media due to the heat generated by the product.
- Adhere to the applicable regulations and take the necessary precautions for all work you are going to do and consider the safety instructions in this document.
- Before beginning to work, find out whether any vacuum components are contaminated. Adhere to the relevant regulations and take the necessary precautions when handling contaminated parts.

Communicate the safety instructions to all other users.

## 1.4 Liability and Warranty

Inficon assumes no liability and the warranty becomes null and void if the end-user or third parties

- disregard the information in this document
- use the product in a non-conforming manner
- make any kind of interventions (modifications, alterations etc.) on the product
- use the product with accessories not listed in the corresponding product documentation.

The end-user assumes the responsibility in conjunction with the process media used.

## 2 Technical Data

Part number	Nominal voltage
250-530	24 VDC ±10%
250-531	24 VAC ±10%, 50 ... 60 Hz
250-532	115 VAC ±10%, 50 ... 60 Hz
250-533	230 VAC ±10%, 50 ... 60 Hz
Vacuum connection	DN 10 ISO-KF
Version	normally closed
Electrical connection	cable socket
Protection type	IP65
Pickup power	35 VA
Holding power	15 VA
Duty cycle	100% (i.e. continuous duty possible)
Mounting orientation	any
Actuation	opens electromagnetically closes with pressure spring
Conductance at	
1 mbar	3.5 l/s
0.1 mbar	1.3 l/s
Molecular flow	1.0 l/s
Switching frequency	50/min <sup>1)</sup>
Opening time	45 ms
Closing time	60 ms
Cycles to first maintenance	1,500,000 <sup>2)</sup>
Venting time	23 s for 100 l
Tightness	1×10 <sup>-9</sup> mbar l/s
Pressure range	1×10 <sup>-8</sup> mbar ... 10 bar (absolute)
Pressure difference Δp	
In closing direction	10 bar
In opening direction	1 bar
Opens to a pressure difference Δp	2 bar
Temperatures	
Operation (ambient)	5 ... 40 °C
Operation on continuous duty	75 °C
Bakeout with idle coil	80 °C
Bakeout without coil	150 °C
Storage	5 ... 50 °C
Materials	
Housing	Al 3.2315
Valve plate/guide tube	X4CrMoS18
Pressure spring	stainless steel
Valve seat seal	FPM
Filter	sintered bronze
Protective lids	PE
Packing	carton box, foamed material
Weight	0.46 kg

<sup>1)</sup> With pressure difference Δp = 0.

<sup>2)</sup> Under clean operating conditions.

## Dimensions

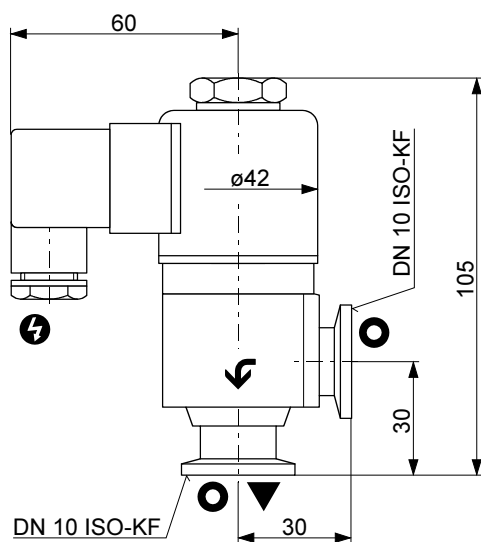

With filter  
(accessories)

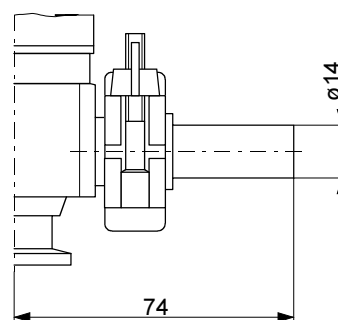

- Preferred flow direction
- Power connection
- Valve seat side
- Protective lid

## Venting time

Venting time as a function of the volume.

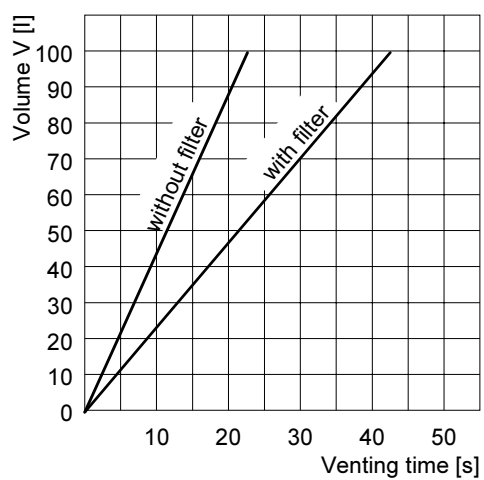

## 3 Installation

### 3.1 Supply Voltage



#### Caution

Caution: Supply voltage

A wrong supply voltage may damage the product.

The supply voltage must correspond to the nominal voltage of the product (→ product nameplate). If it does not, please contact your local Inficon service center.

### 3.2 Vacuum Connection



#### DANGER

Caution: overpressure in the vacuum system >1 bar

Injury caused by released parts and harm caused by escaping process gases can result if clamps are opened while the vacuum system is pressurized.

Do not open any clamps while the vacuum system is pressurized. Use the type clamps which are suited to overpressure.



#### DANGER

Caution: overpressure in the vacuum system >4 bar

KF flange connections with elastomer seals (e.g. O-rings) cannot withstand such pressures. Process media can thus leak and possibly damage your health.

Use O-rings provided with an outer centering ring.



#### Caution

Caution: dirt sensitive area

Touching the product or parts thereof with one's bare hands increases the desorption rate.

Always wear clean, lint-free gloves and use clean tools when working in this area.



#### Caution

Caution: vacuum component

Dirt and damages impair the function of the vacuum component.

When handling vacuum components, take appropriate measures to ensure cleanliness and prevent damages.

Procedure

Remove the protective lids and install the product to the vacuum system.

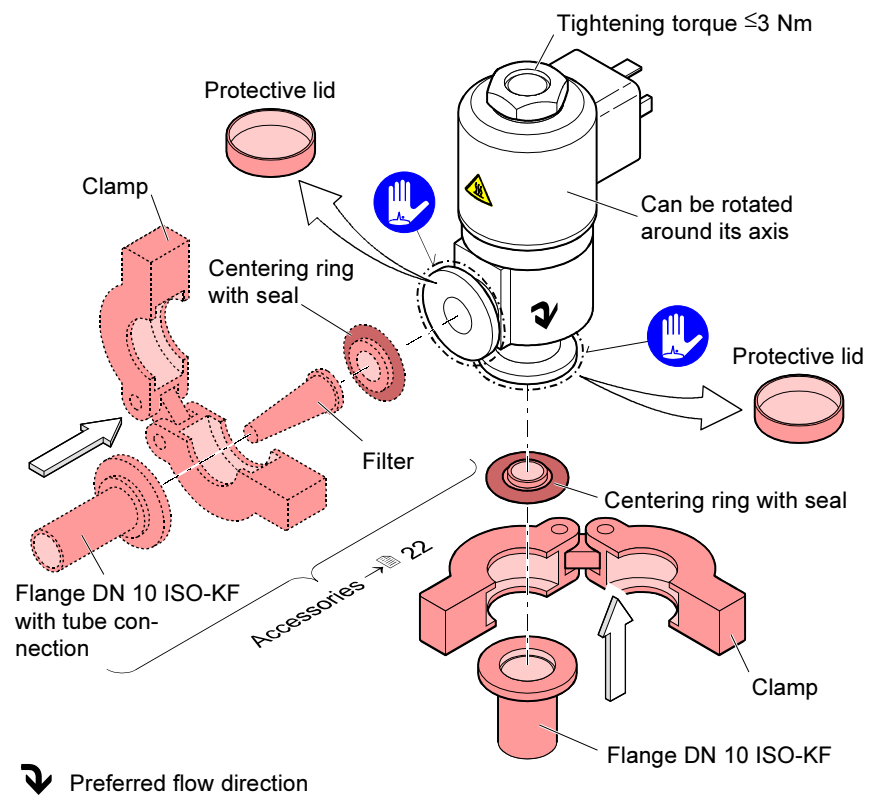

To prevent contamination of the vacuum system during venting, a filter (accessory) can be mounted.

### 3.3 Power Connection

#### Preparing the cable socket

- 1 Unfasten the screw and unplug the cable socket.

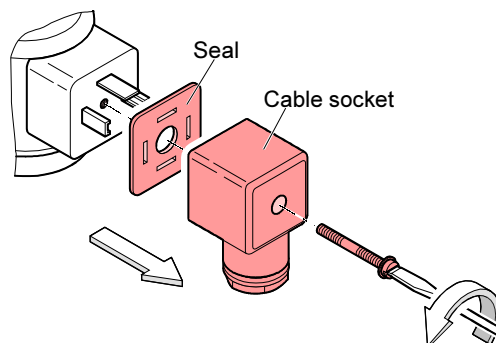

- 2 Remove the insert.

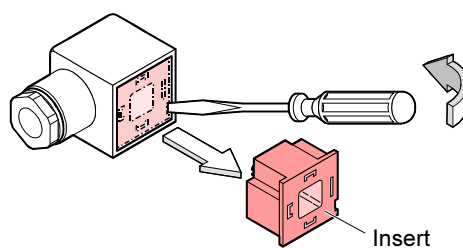

- 3 Unscrew the nut on the cable socket and remove the washer and the sealing washer.

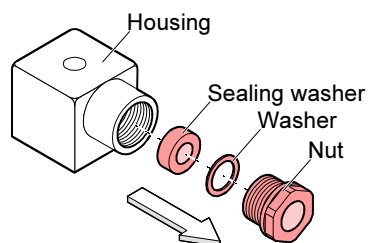

#### Preparing and connecting the cable

- 4 Slide the nut, washer, sealing washer and housing on the cable.

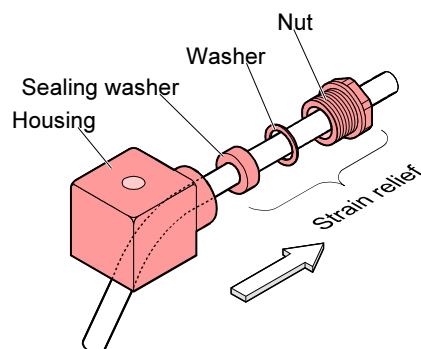

**5** Prepare the cable.

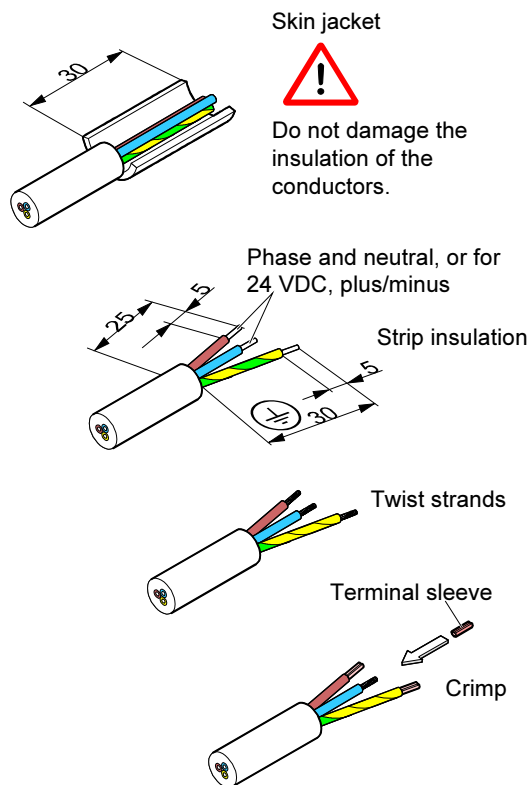

**6** Connect the cable.

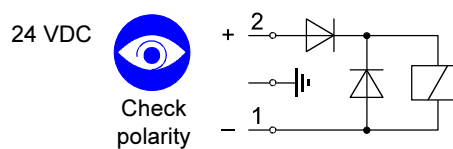
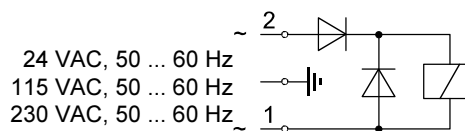
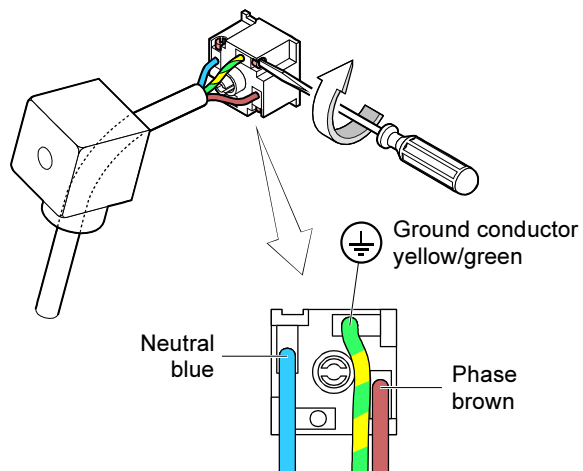

## Assembling the cable socket

- 7** Push the insert in until it catches.

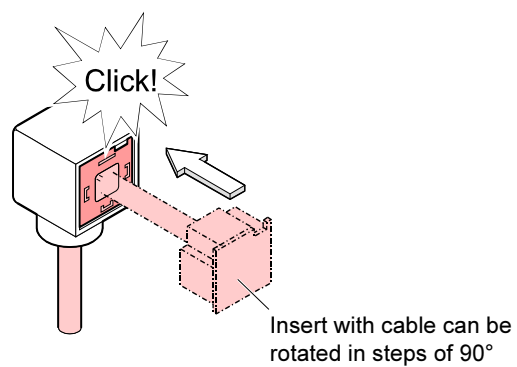

- 8** Push the strain relief into the housing.

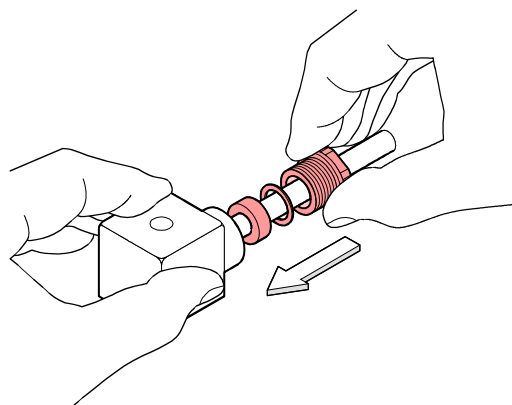

- 9** Tighten the strain relief.

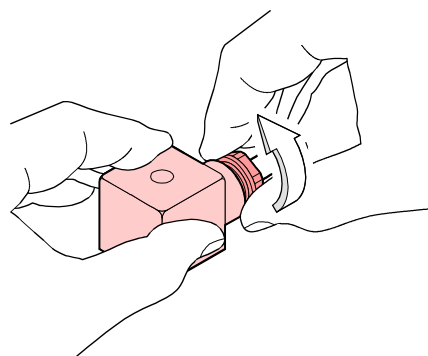

Connecting the cable socket to the soleroid coil

- 10 Mount the seal, plug in the cable socket, and secure it with the screw.

**DANGER**

**Caution: protective ground**  
 Incorrectly grounded products can be extremely hazardous in the event of a fault.

Use only a 3-conductor power cable with protective ground. The power connector may only be plugged into a socket with a protective ground. The protection must not be nullified by an extension cable without protective ground.



Before connecting or disconnecting the product, turn off the control system.

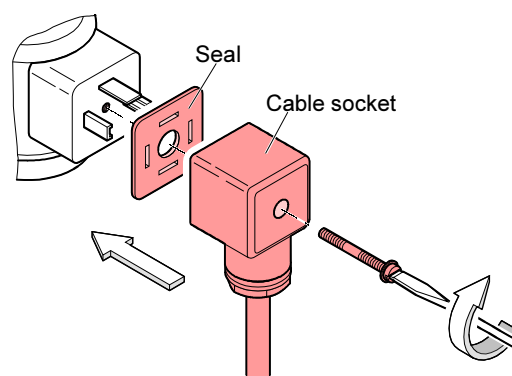

## 4 Operation

The product is ready for operation as soon as it has been installed.

It will close, or remain closed, on power loss.

**DANGER**

**Caution: hot surface**  
 Touching the hot surface ( $>55\text{ }^{\circ}\text{C}$ ) can cause burns.  
 Wear protective gloves.

Pressure difference  $\Delta p$  in closing direction

**Caution**

Closing direction

**Caution: pressure difference  $\Delta p$**   
 At  $\Delta p$  10 bar the valve cannot be opened.  
 Avoid pressure differences  $\Delta p > 2$  bar.

Pressure difference  $\Delta p$  in opening direction

**Caution**

Opening direction

**Caution: pressure difference  $\Delta p$**   
 At  $\Delta p > 1$  bar the valve cannot open.  
 Avoid pressure differences  $\Delta p > 1$  bar.

Opening against a pressure difference  $\Delta p$

**Caution**

Opening

**Caution: pressure difference  $\Delta p$**   
 At  $\Delta p > 2$  bar the valve cannot open.  
 Avoid pressure differences  $\Delta p > 2$  bar.

## 5 Deinstallation

### 5.1 Electrical Connection



Before connecting or disconnecting the product, turn off the control system.

Procedure

Unlock the cable socket and unplug it.

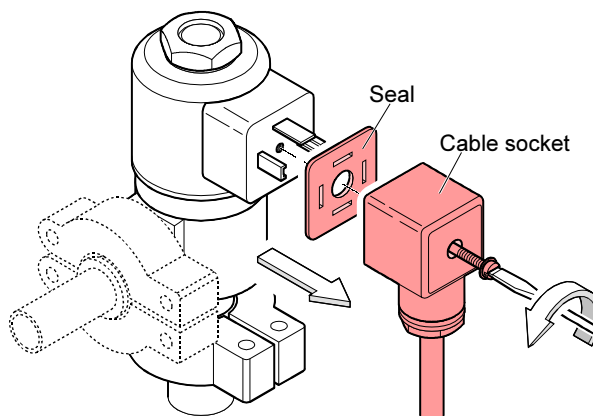

### 5.2 Vacuum Connection

**STOP DANGER**



**Caution: contaminated parts**

Contaminated parts can be detrimental to health and environment.

Before beginning to work, find out whether any parts are contaminated. Adhere to the relevant regulations and take the necessary precautions when handling contaminated parts.



**Caution**



**Caution: vacuum component**

Dirt and damages impair the function of the vacuum component.

When handling vacuum components, take appropriate measures to ensure cleanliness and prevent damages.



**Caution**



**Caution: dirt sensitive area**

Touching the product or parts thereof with one's bare hands increases the desorption rate.

Always wear clean, lint-free gloves and use clean tools when working in this area.

Preconditions

- Vacuum system vented
- Product cooled down to <math><55\text{ }^{\circ}\text{C}</math>

Procedure

Remove the small flange fittings and put the protective lids in place.

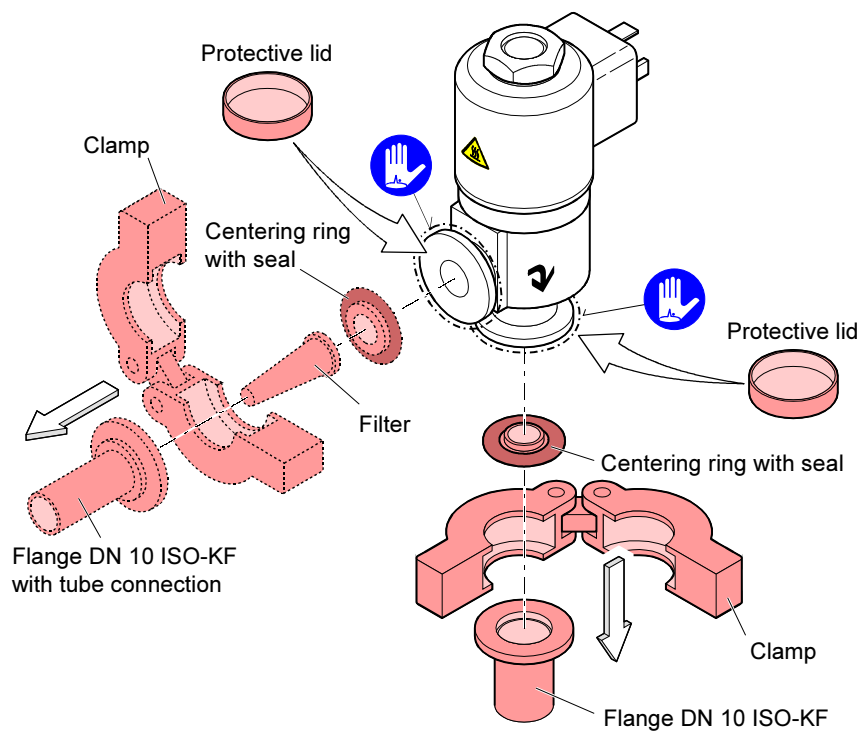

## 6 Maintenance / Repair

Under clean operating conditions, the product requires no maintenance during the rated cycle life.

### 6.1 Replacing / Cleaning the Filter

Replacing the filter ...



We recommend to use a new filter (Spare parts → 23).

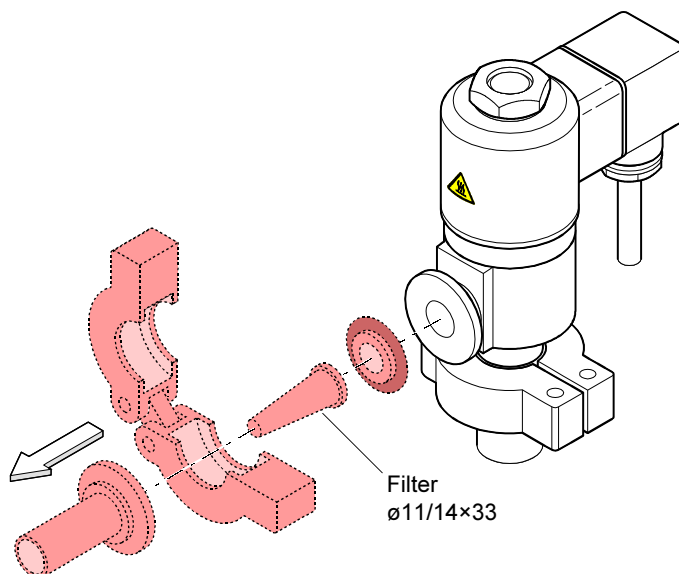

... or cleaning the filter



**DANGER**



Caution: cleaning agents

Cleaning agents can be detrimental to health and environment.

Adhere to the relevant regulations and take the necessary precautions when handling and disposing of cleaning agents. Consider possible reactions with the product materials (→ 5).

Clean the filter in an ultrasonic bath rinse it with alcohol and dry it with an industrial blower.

## 6.2 Cleaning the Valve / Replacing Parts



**DANGER**

Caution: contaminated parts

Contaminated parts can be detrimental to health and environment. Before beginning to work, find out whether any parts are contaminated. Adhere to the relevant regulations and take the necessary precautions when handling contaminated parts.



**Caution**



Caution: vacuum component

Dirt and damages impair the function of the vacuum component.

When handling vacuum components, take appropriate measures to ensure cleanliness and prevent damages.

Precondition

Valve deinstalled (→ 14).

Disassembling the valve



Remove the solenoid coil.

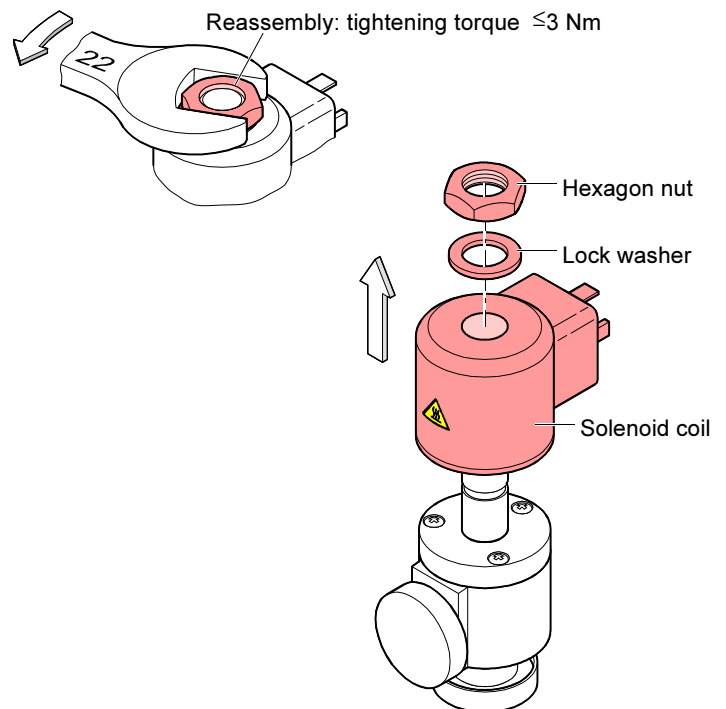

- 2** Remove the collar flange and seal.

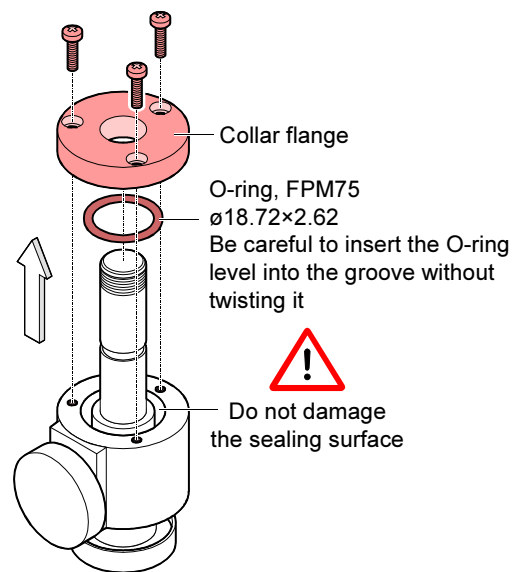

- 3** Remove the guide tube, pressure spring, and valve plate from the housing.

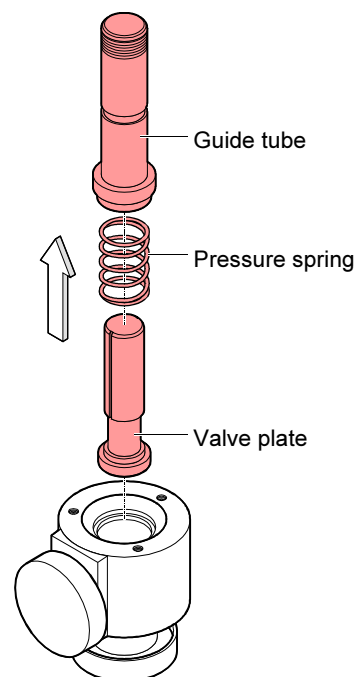

**4** Remove the seal from the valve plate.

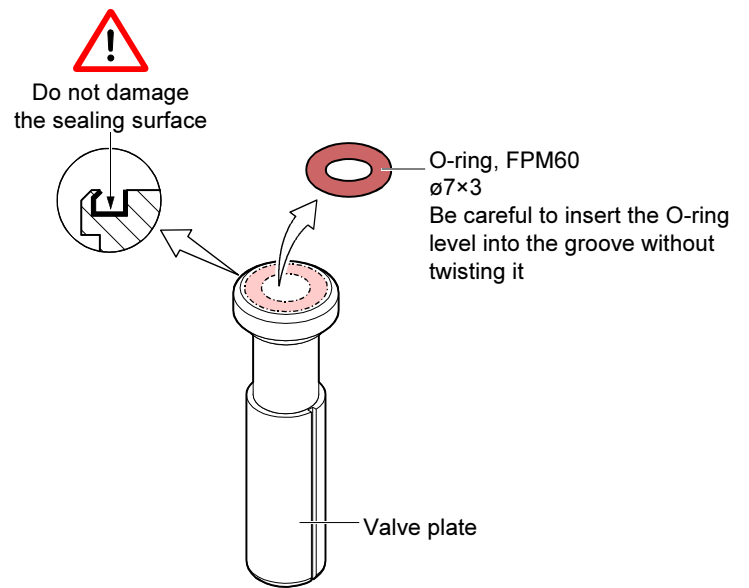

Cleaning the valve /  
replacing parts

**5** Clean the valve and replace its parts (Spare parts → 23).



**DANGER**

Caution: cleaning agents  
Cleaning agents can be detrimental to health and environment.  
Adhere to the relevant regulations and take the necessary  
precautions when handling and disposing of cleaning agents.  
Consider possible reactions with the product materials (→ 5).

- Carefully clean the parts with a grease solving, non-scouring cleaner.
- After cleaning, the parts should preferably be rinsed with alcohol and subsequently heated to  $\approx 50^{\circ}\text{C}$  in an oven or with an industrial blower.
- Carefully clean the sealing surfaces with a lint-free cloth soaked with alcohol. Allow them to dry.
- Wipe the seals with a lint-free cloth slightly moistened with vacuum oil.

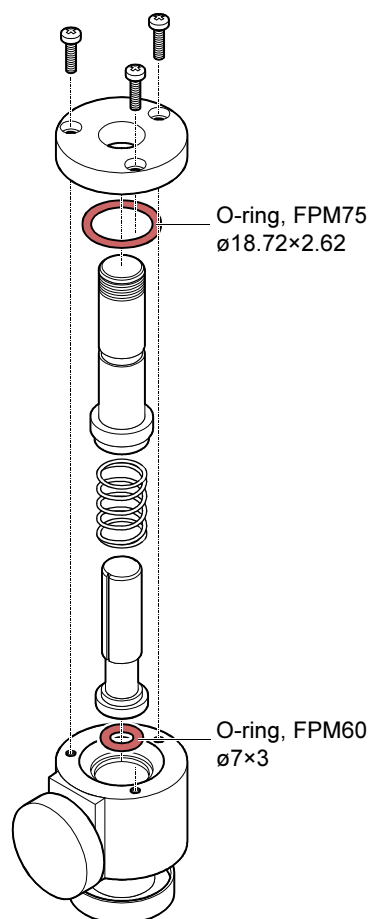

## Reassembling the valve

- 6** Proceed in reverse order to reassemble the valve.



**Caution**



Caution: vacuum component  
Dirt and damages impair the function of the vacuum component.  
When handling vacuum components, take appropriate measures to ensure cleanliness and prevent damages.



**Caution**



Caution: dirt sensitive area  
Touching the product or parts thereof with one's bare hands increases the desorption rate.  
Always wear clean, lint-free gloves and use clean tools when working in this area.

-  After reassembly, a few switching cycles should be performed in order for the O-rings to perfectly adapt to the sealing surfaces. Take the necessary precautions for this procedure.

## 7 Accessories

Filter kit

Ordering number 215-152  
Comprising:

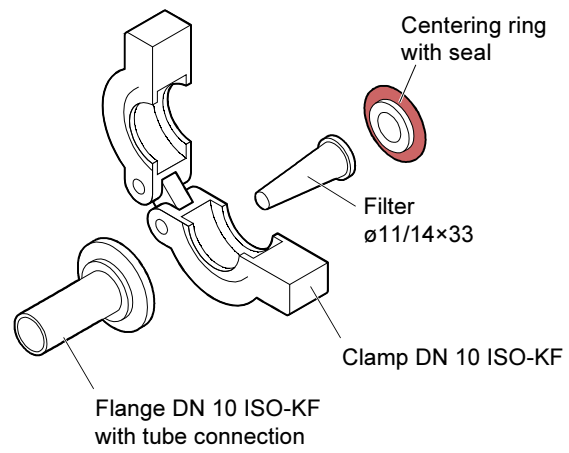

## 8 Spare Parts

Seal kit

Ordering number 215-208  
Comprising:

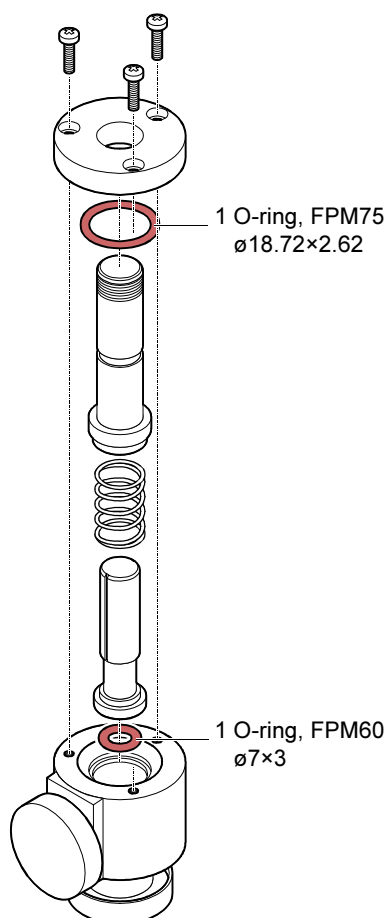

Filter

Ordering number B 4161 210 4F

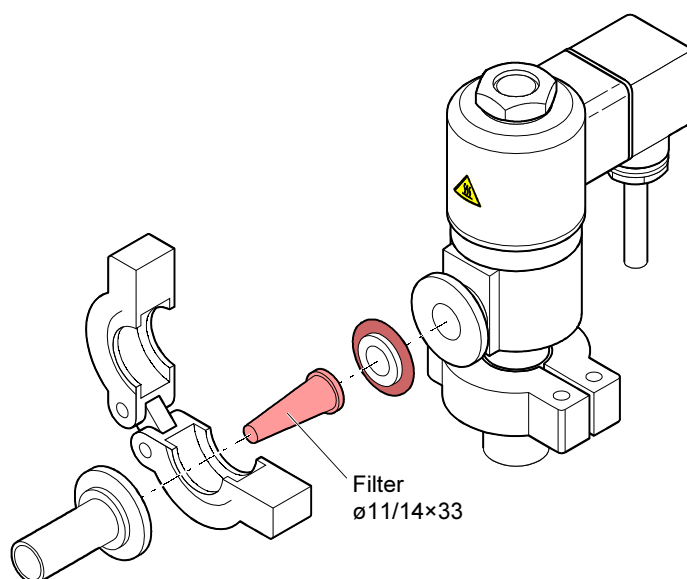

## 9 Storage



### Caution



Caution: vacuum component

Inappropriate storage leads to an increase of the desorption rate and/or may result in mechanical damage of the product.

Cover the vacuum ports of the product with protective lids or grease free aluminum foil. Do not exceed the admissible storage temperature range (→ 5).

## 10 Returning the Product



### WARNING



Caution: forwarding contaminated products

Contaminated products (e.g. radioactive, toxic, caustic or microbiological hazard) can be detrimental to health and environment.

Products returned to Inficon should preferably be free of harmful substances. Adhere to the forwarding regulations of all involved countries and forwarding companies and enclose a duly completed declaration of contamination (→ 26).

Products that are not clearly declared as "free of harmful substances" are decontaminated at the expense of the customer.

Products not accompanied by a duly completed declaration of contamination are returned to the sender at his own expense.

## 11 Disposal



**DANGER**



**Caution: contaminated parts**

Contaminated parts can be detrimental to health and environment. Before beginning to work, find out whether any parts are contaminated. Adhere to the relevant regulations and take the necessary precautions when handling contaminated parts.

**WARNING**



**Caution: substances detrimental to the environment**

Products or parts thereof (mechanical and electric components, operating fluids etc.) can be detrimental to the environment. Dispose of such substances in accordance with the relevant local regulations.

### Separating the components

After disassembling the product, separate its components according to the following criteria:

#### Contaminated components

Contaminated components (radioactive, toxic, caustic, or biological hazard etc.) must be decontaminated in accordance with the relevant national regulations, separated according to their materials, and disposed of.

#### Other components

Such components must be separated according to their materials and recycled.

# Declaration of Contamination

The service, repair, and/or disposal of vacuum equipment and components will only be carried out if a correctly completed declaration has been submitted. Non-completion will result in delay.  
 This declaration may only be completed (in block letters) and signed by authorized and qualified staff.

**1 Description of product**

Type \_\_\_\_\_

Article Number \_\_\_\_\_

Serial Number \_\_\_\_\_

**2 Reason for return**

\_\_\_\_\_

\_\_\_\_\_

**3 Operating fluid(s) used (Must be drained before shipping.)**

\_\_\_\_\_

**4 Process related contamination of product:**

toxic	no <input type="checkbox"/> 1)	yes <input type="checkbox"/>	<p>2) Products thus contaminated will not be accepted without written evidence of decontamination!</p>
caustic	no <input type="checkbox"/> 1)	yes <input type="checkbox"/>	
biological hazard	no <input type="checkbox"/>	yes <input type="checkbox"/> 2)	
explosive	no <input type="checkbox"/>	yes <input type="checkbox"/> 2)	
radioactive	no <input type="checkbox"/>	yes <input type="checkbox"/> 2)	
other harmful substances	no <input type="checkbox"/> 1)	yes <input type="checkbox"/>	

1) or not containing any amount of hazardous residues that exceed the permissible exposure limits

The product is free of any substances which are damaging to health

yes

**5 Harmful substances, gases and/or by-products**

Please list all substances, gases, and by-products which the product may have come into contact with:

Trade/product name	Chemical name (or symbol)	Precautions associated with substance	Action if human contact

**6 Legally binding declaration:**

I/we hereby declare that the information on this form is complete and accurate and that I/we will assume any further costs that may arise. The contaminated product will be dispatched in accordance with the applicable regulations.

Organization/company \_\_\_\_\_

Address \_\_\_\_\_ Post code, place \_\_\_\_\_

Phone \_\_\_\_\_ Fax \_\_\_\_\_

Email \_\_\_\_\_

Name \_\_\_\_\_

Date and legally binding signature \_\_\_\_\_ Company stamp \_\_\_\_\_

Notes

Original: German sina65d1 (0104)



sina65d1



*LI-9496 Balzers  
Liechtenstein  
Tel +423 / 388 3111  
Fax +423 / 388 3700  
reach.liechtenstein@inficon.com*

*www.inficon.com*