

## Dosing Valve VDH016-X

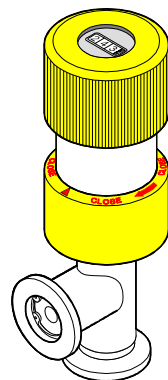

CE

## Product Identification

In all communications with Inficon, please specify the information on the product nameplate. For convenient reference copy that information into the space provided below.

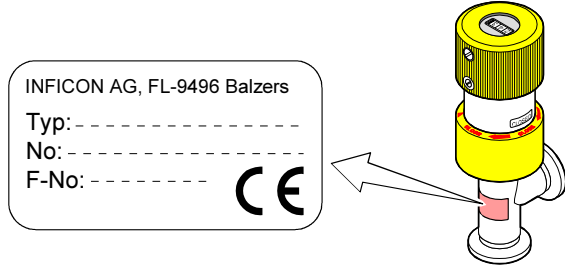

## Validity

This document applies to products with part number 250-500.

The part number can be taken from the product nameplate.

## Intended Use

The manually actuated VDH016-X Dosing valve is used for both, gas dosing and shutting off a defined gas flow without changing the gas flow setting.

The VDH016-X must not be used in connection with liquid gases.

## Functional Principle

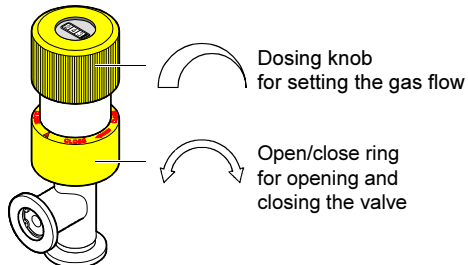



Rotating the dosing knob translates into a linear movement and places the dosing needle reproducibly in the desired position.

Rotating the Open/close ring positions the valve plate. These movements are independent of each other.

## Contents

Product Identification	2
Validity	2
Intended Use	2
Function	2
<b>1 Safety</b>	<b>4</b>
1.1 Symbols Used	4
1.2 Personnel Qualifications	4
1.3 General Safety Instructions	5
1.4 Liability and Warranty	5
<b>2 Technical Data</b>	<b>6</b>
<b>3 Installation</b>	<b>8</b>
<b>4 Operation</b>	<b>10</b>
<b>5 Gas Flow</b>	<b>12</b>
5.1 Gas Flow Curve	12
5.2 Conversion Table	12
<b>6 Deinstallation</b>	<b>13</b>
<b>7 Maintenance</b>	<b>15</b>
<b>8 Repair</b>	<b>17</b>
<b>9 Accessories</b>	<b>18</b>
<b>10 Storage</b>	<b>19</b>
<b>11 Returning the Product</b>	<b>19</b>
<b>12 Disposal</b>	<b>20</b>
<b>Declaration of Contamination</b>	<b>21</b>
<b>Manufacturer's Declaration</b>	<b>22</b>

For cross-references within this document, the symbol (→  XY) is used, for cross-references to other documents, the symbol (→  [Z]).

# 1 Safety

## 1.1 Symbols Used

DANGER

Information on preventing any kind of physical injury.

WARNING

Information on preventing extensive equipment and environmental damage.

Caution

Information on correct handling or use. Disregard can lead to malfunctions or minor equipment damage.

 Dimensions in mm

## 1.2 Personnel Qualifications

Skilled personnel

All work described in this document may only be carried out by persons who have suitable technical training and the necessary experience or who have been instructed by the end-user of the product.

### 1.3 General Safety Instructions

- Adhere to the applicable regulations and take the necessary precautions for the process media used.
- Adhere to the applicable regulations and take the necessary precautions for all work you are going to do and consider the safety instructions in this document.
- Before beginning to work, find out whether any vacuum components are contaminated. Adhere to the relevant regulations and take the necessary precautions when handling contaminated parts.

Communicate the safety instructions to all other users.

### 1.4 Liability and Warranty

Inficon assumes no liability and the warranty becomes null and void if the end-user or third parties

- disregard the information in this document
- use the product in a non-conforming manner
- make any kind of interventions (modifications, alterations etc.) on the product
- use the product with accessories not listed in the corresponding product documentation.

The end-user assumes the responsibility in conjunction with the process media used.

## 2 Technical Data

Connection flanges	DN 16 ISO-KF
Mounting orientation	any
Dosing range	$5 \times 10^{-6} \dots 1000$ mbar l/s
Tightness	$1 \times 10^{-9}$ mbar l/s
Pressure difference	$\leq 2.5$ bar
Operating temperature	80 °C
Bakeout temperature	$\leq 150$ °C *)
Storage temperature	5 ... 40 °C
Dead volume	0.032 cm <sup>3</sup>
Materials	
Housing, needle, filter	stainless steel
Dosing sleeve	fluor plastomer
Seal	FPM75
Weight	400 g

\*) at the flange connections

### Dimensions

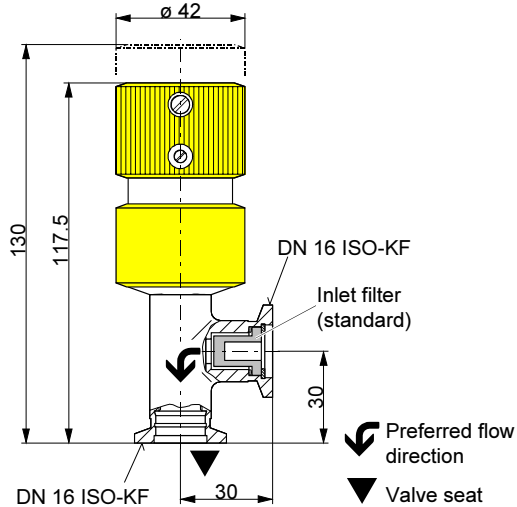

**Gas flow with standard filter 1700 mbar l/s**

**Gas flow without standard filter 3100 mbar l/s**

Accessories

Filter

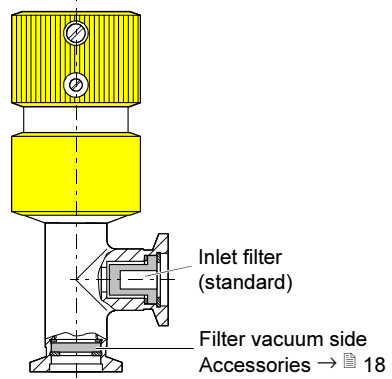

**Gas flow 590 mbar l/s**

Filter

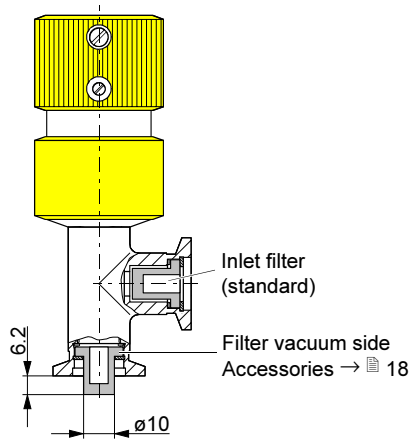

**Gas flow 1250 mbar l/s**

### 3 Installation

**DANGER**



Caution: overpressure in the vacuum system >1 bar

Injury caused by released parts and harm caused by escaping process gases can result if clamps are opened while the vacuum system is pressurized.

Do not open any clamps while the vacuum system is pressurized. Use the type clamps which are suited to overpressure.

**Caution**



Caution: dirt sensitive area

Touching the product or parts thereof with one's bare hands increases the desorption rate.

Always wear clean, lint-free gloves and use clean tools when working in this area.

**Caution**



Caution: vacuum component

Dirt and damages impair the function of the vacuum component.

When handling vacuum components, take appropriate measures to ensure cleanliness and prevent damages.



Keep the lids.

Flow direction

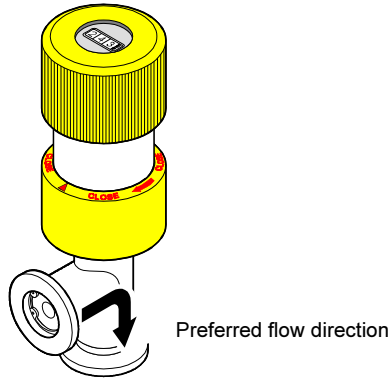

Vacuum connection

Remove the lid and connect the valve to the vacuum system using the small flange connections.

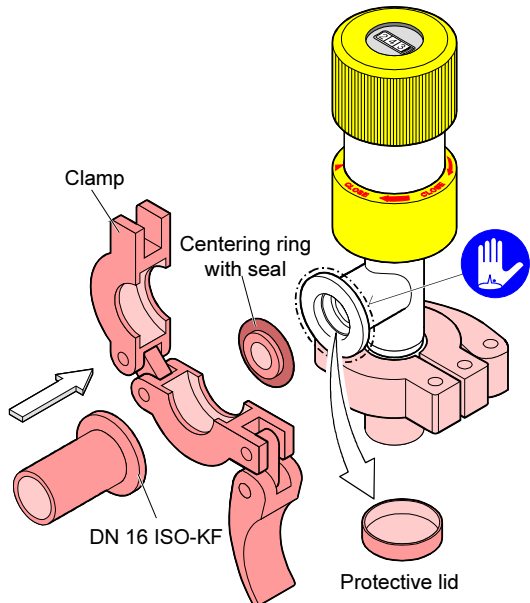

## 4 Operation

The product is ready for operation as soon as it has been installed.

**DANGER**

Caution: hot surface  
Touching the hot surface (>55 °C) can cause burns.  
Wear protective gloves.

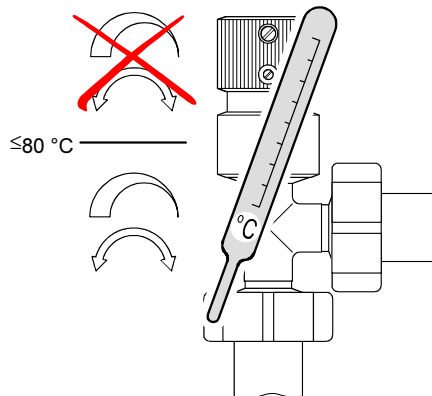
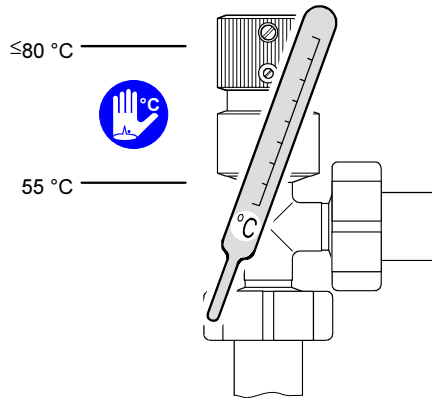

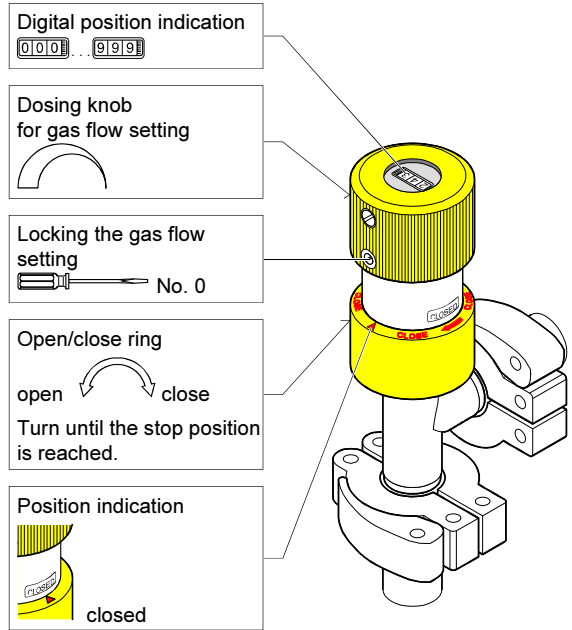

## Dead volume

Due to the gas dosing and valve seat seals, there is a dead volume of  $0.032 \text{ cm}^3$ .

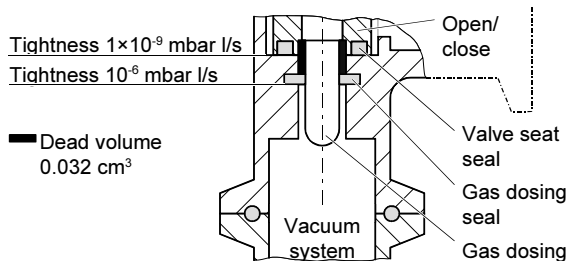

If the pressure in the dead volume is higher than in the vacuum system, the pressure between the dead volume and the vacuum system is compensated. During the compensation phase, one could come to the **false** conclusion that the valve is not tight.

Leak flow rate for pressure compensation =  
 $10^{-6} \text{ mbar l/s} \times \text{pressure difference}$

## 5 Gas Flow

### 5.1 Gas Flow Curve

Using the gas flow curve, the digital indication on the dosing knob and the gas flow can be related to each other.

The gas flow rates in the diagram are mean values.

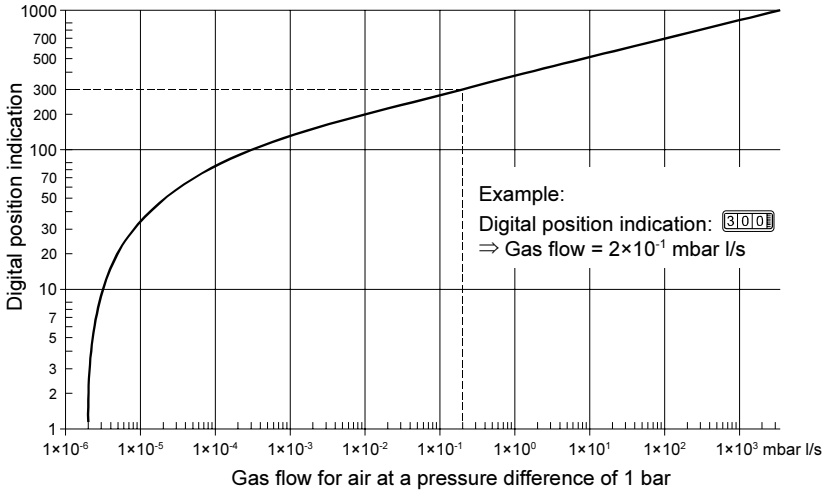

### 5.2 Conversion Table

Gas flow

	mbar l/s	Torr l/s	sccm	atm cm <sup>3</sup> /s
mbar l/s	1	0.75	59.2	0.987
Torr l/s	1.33	1	78.9	1.32
sccm	$1.69 \times 10^{-2}$	$1.27 \times 10^{-2}$	1	$1.67 \times 10^{-2}$
atm cm <sup>3</sup> /s	1.01	0.76	59.8	1

## 6 Deinstallation



### DANGER

Caution: contaminated parts

Contaminated parts can be detrimental to health and environment.

Before beginning to work, find out whether any parts are contaminated. Adhere to the relevant regulations and take the necessary precautions when handling contaminated parts.



### Caution



Caution: vacuum component

Dirt and damages impair the function of the vacuum component.

When handling vacuum components, take appropriate measures to ensure cleanliness and prevent damages.



### Caution



Caution: dirt sensitive area

Touching the product or parts thereof with one's bare hands increases the desorption rate.

Always wear clean, lint-free gloves and use clean tools when working in this area.

- ❶ Vent the vacuum system and let it cool down to <math><55\text{ }^\circ\text{C}</math>.

- ② Remove the small flange fittings and put the protective lids in place.

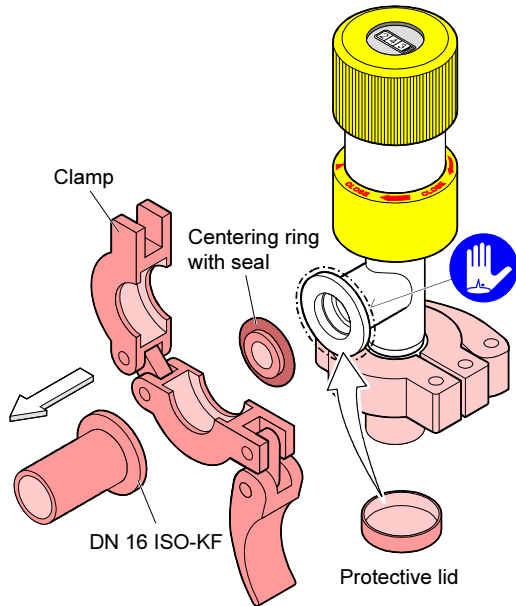

## 7 Maintenance

Cleaning the filter(s)

- ❶ Remove the valve from the vacuum system according to section "Deinstallation".
- ❷ Remove the lid(s).

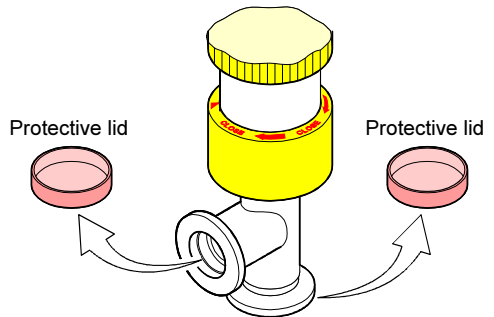

- ❸ Remove the filter(s).

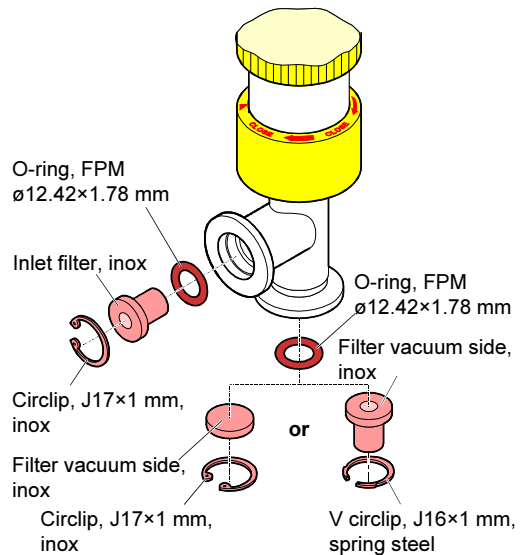

- ④ Clean the filter(s) with alcohol.

**DANGER**





Caution: cleaning agents

Cleaning agents can be detrimental to health and environment.

Adhere to the relevant regulations and take the necessary precautions when handling and disposing of cleaning agents. Consider possible reactions with the product materials (→  6).

- ⑤ Dry the filter(s) with compressed air.

**DANGER**



Caution: compressed air

Unprofessionally handling compressed air can cause physical injuries.

Adhere to the relevant regulations and take the necessary precautions when handling compressed air.



The compressed air must meet the following specifications:

- free of oil
- dry
- free of particles >25 µm

- ⑤ Reinstall the filter and connect the Dosing valve to the vacuum system according to section "Installation".

## 8 Repair

We recommend returning the product to your local Inficon service center for repair.

Inficon assumes no liability and the warranty becomes null and void if any repair work is carried out by the end-user or third parties.

## 9 Accessories

If the dosing needle can be contaminated by the process, installing a filter at the vacuum port of the valve is strongly recommended.

Filter vacuum side  
(gas flows 590 mbar l/s)

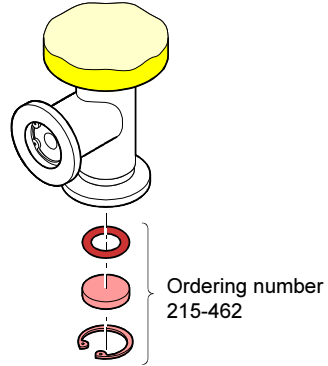

Filter vacuum side  
(gas flow 1250 mbar l/s)

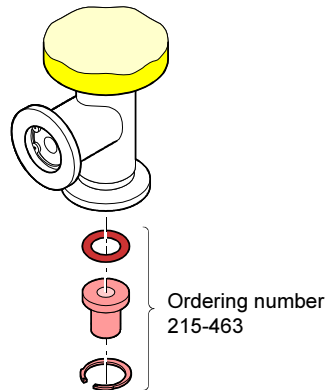

## 10 Storage



### Caution



Caution: vacuum component  
 Inappropriate storage leads to an increase of the desorption rate and/or may result in mechanical damage of the product.  
 Cover the vacuum ports of the product with protective lids or grease free aluminum foil. Do not exceed the admissible storage temperature range (→ 6).

## 11 Returning the Product



### WARNING



Caution: forwarding contaminated products  
 Contaminated products (e.g. radioactive, toxic, caustic or microbiological hazard) can be detrimental to health and environment.  
 Products returned to Inficon should preferably be free of harmful substances. Adhere to the forwarding regulations of all involved countries and forwarding companies and enclose a duly completed declaration of contamination (→ 21).

Products that are not clearly declared as "free of harmful substances" are decontaminated at the expense of the customer.

Products not accompanied by a duly completed declaration of contamination are returned to the sender at his own expense.

## 12 Disposal



**DANGER**



**Caution: contaminated parts**  
Contaminated parts can be detrimental to health and environment.

Before beginning to work, find out whether any parts are contaminated. Adhere to the relevant regulations and take the necessary precautions when handling contaminated parts.

**WARNING**



**Caution: substances detrimental to the environment**

Products or parts thereof (mechanical and electric components, operating fluids etc.) can be detrimental to the environment.

Dispose of such substances in accordance with the relevant local regulations.

Separating the components

Contaminated components

Other components

After disassembling the product, separate its components according to the following criteria:

Contaminated components (radioactive, toxic, caustic, or biological hazard etc.) must be decontaminated in accordance with the relevant national regulations, separated according to their materials, and disposed of.

Such components must be separated according to their materials and recycled.

# Declaration of Contamination

The service, repair, and/or disposal of vacuum equipment and components will only be carried out if a correctly completed declaration has been submitted. Non-completion will result in delay.  
This declaration may only be completed (in block letters) and signed by authorized and qualified staff.

**1 Description of product**  
 Type \_\_\_\_\_  
 Article Number \_\_\_\_\_  
 Serial Number \_\_\_\_\_

**2 Reason for return**  
 \_\_\_\_\_  
 \_\_\_\_\_

**3 Operating fluid(s) used (Must be drained before shipping.)**  
 \_\_\_\_\_  
 \_\_\_\_\_

**4 Process related contamination of product:**

toxic	no <input type="checkbox"/> 1)	yes <input type="checkbox"/>	 <p>2) Products thus contaminated will not be accepted without written evidence of decontamination!</p>
caustic	no <input type="checkbox"/> 1)	yes <input type="checkbox"/>	
biological hazard	no <input type="checkbox"/>	yes <input type="checkbox"/> 2)	
explosive	no <input type="checkbox"/>	yes <input type="checkbox"/> 2)	
radioactive	no <input type="checkbox"/>	yes <input type="checkbox"/> 2)	
other harmful substances	no <input type="checkbox"/> 1)	yes <input type="checkbox"/>	

1) or not containing any amount of hazardous residues that exceed the permissible exposure limits

The product is free of any substances which are damaging to health    yes

**5 Harmful substances, gases and/or by-products**  
 Please list all substances, gases, and by-products which the product may have come into contact with:

Trade/product name	Chemical name (or symbol)	Precautions associated with substance	Action if human contact

**6 Legally binding declaration:**  
 I/we hereby declare that the information on this form is complete and accurate and that I/we will assume any further costs that may arise. The contaminated product will be dispatched in accordance with the applicable regulations.

Organization/company \_\_\_\_\_

Address \_\_\_\_\_      Post code, place \_\_\_\_\_

Phone \_\_\_\_\_      Fax \_\_\_\_\_

Email \_\_\_\_\_

Name \_\_\_\_\_

Date and legally binding signature \_\_\_\_\_      Company stamp \_\_\_\_\_

This form can be downloaded from our website.

Copies:  
Original for addressee - 1 copy for accompanying documents - 1 copy for file of sender

## Manufacturer's Declaration



as defined by the Directive relating to machinery 98/37/EC, Appendix IIb.

We, Inficon, hereby declare that putting the incomplete equipment mentioned below into operation is not permitted until evidence is given that the system into which that incomplete equipment shall be installed is in accordance with the provisions of the EC Directive relating to machinery.

Product

**Dosing Valve**  
VDH016-X

Part number

250-500

Standards

Harmonized and international/national standards and specifications:

- EN 292-1/-2 (Safety of machinery)
- DIN 28403 (ISO 2861 small flange connections)

Signatures

Inficon AG, Balzers  
7 November 2000



Robert Polacek  
Product management

7 November 2000



Oskar Untermarzoner  
Product development

## Notes



*LI-9496 Balzers  
Liechtenstein  
Tel +423 / 388 3111  
Fax +423 / 388 3700  
reach.liechtenstein@inficon.com*

*Original: German sina64d1 (0011)*



s1 na94e1

*www.inficon.com*