

Angle Valve

manually actuated
bellows sealed
with spindle drive

VAH063 ... 100-A/X

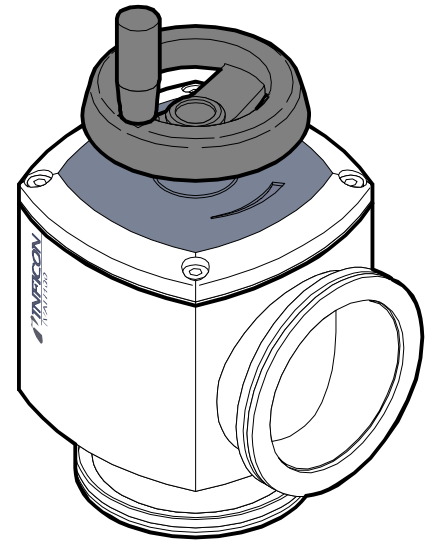

CE

Product Identification

In all communications with Inficon, please specify the information on the product nameplate. For convenient reference copy that information into the space provided below.

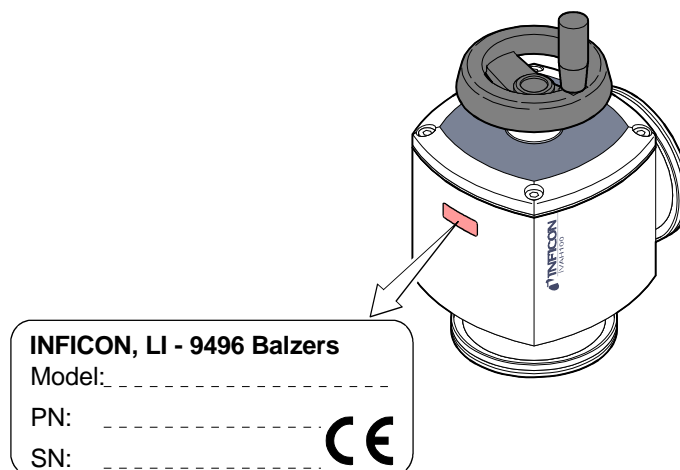

Validity

This document applies to products with the following part numbers:

Aluminum housing	250-470	(DN 63 ISO-K)
	250-480	(DN 100 ISO-K)
Stainless steel housing	250-475	(DN 63 ISO-K)
	250-485	(DN 100 ISO-K)

The part number can be taken from the product nameplate.

If not indicated otherwise in the legends, the illustrations in this document correspond to Angle valves with the DN 100 ISO-K vacuum connection. They apply to Angle valves with the DN 63 ISO-K vacuum connection by analogy.

We reserve the right to make technical changes without prior notice.

All dimensions are indicated in mm.

Intended Use

The Angle valves are used as shut-off and venting devices for vacuum applications.

Contents

Product Identification	2
Validity	2
Intended Use	2
1 Description	4
1.1 Over view	4
1.2 Functional Principle	4
2 Safety	5
2.1 Symbols Used	5
2.2 General Safety Instructions	5
2.3 Liability and Warranty	5
3 Technical Data	6
4 Installation	7
5 Operation	8
6 Deinstallation	9
7 Maintenance / Repair	11
7.1 Disassembling the Valve	12
7.2 Deinstalling the Bellows	14
7.3 Cleaning the Valve	15
7.4 Reinstalling the Bellows	16
7.5 Reassembling the Valve	18
8 Spare Parts	20
9 Returning the Product	21
10 Disposal	21
Declaration of Contamination	22

1 Description

1.1 Over view

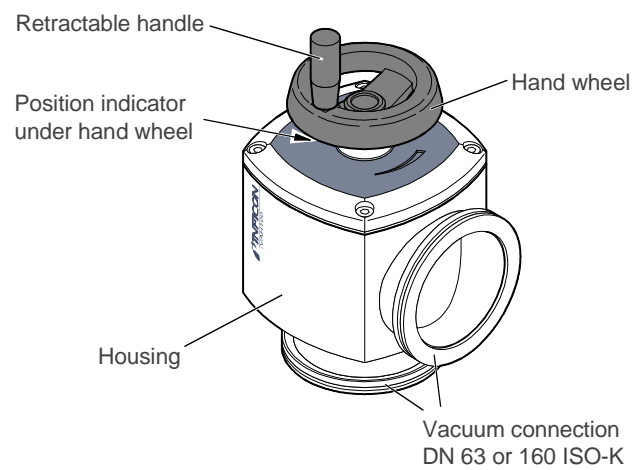

1.2 Functional Principle

The Angle valve is opened by turning the hand wheel counter-clockwise and closed by turning the hand wheel clockwise.

2 Safety

2.1 Symbols Used



Information on preventing any kind of physical injury.



Information on preventing extensive equipment and environmental damage.



Information on correct handling or use. Disregard can lead to malfunctions or minor equipment damage.

→  See page ...

2.2 General Safety Instructions

- Adhere to the applicable regulations and take the necessary precautions for the process media used.
Consider possible reactions between the materials (→  6) and the process media.
- Adhere to the applicable regulations and take the necessary precautions for all work you are going to do and consider the safety instructions in this document.
- Before beginning to work, find out whether any vacuum components are contaminated. Adhere to the relevant regulations and take the necessary precautions when handling contaminated parts.

Communicate the safety instructions to all other users.

2.3 Liability and Warranty

Inficon assumes no liability and the warranty becomes null and void if end-user or third parties

- disregard the information in this document
- use the product in a non-conforming manner
- make any kind of interventions (modifications, alterations etc.) on the product
- use the product with accessories, options and add-ons not listed in the corresponding product documentation.

The end-user assumes the responsibility in conjunction with the process media used.

3 Technical Data

	Vacuum connection	DN 63 ISO-K	DN 100 ISO-K
	Stroke of valve plate	20 mm	25 mm
	Conductance ¹⁾	140 l/s	330 l/s
	Tightness	1×10 ⁻⁹ mbar l/s (He)	
	Pressure range	1×10 ⁻⁸ mbar ... 1.5 bar (absolute)	
	Bursting pressure	4 bar	
Pressure difference Δp	in closing direction	1.5 bar	
	in opening direction	1.5 bar	
	Opens against a pressure difference Δp of	1.5 bar	
Temperatures	Ambiance	5 °C ... 60 °C	
	Bakeout		
	aluminum housing	150 °C	
	stainless steel housing	150 °C	
	spindle drive	60 °C	
Installation angle	Installation angle	any, easily accessible	
	Flow direction	any	
Materials	Aluminum housing	3.2373.62	
	Stainless steel housing	1.4305	
	Bellows / valve plate	1.4541 / 1.4301	
	Seals	FPM	
	Cover	gray cast iron 20	
	Spindle	1.4305	
	Protective lids	PE	
	Packing	carton box, PE, PU	
	Hand wheel	special-Technopolymer	
Weight	Aluminum housing	3.6 kg	6.1 kg
	Stainless steel housing	6.5 kg	11.1 kg

¹⁾ For air with molecular flow

Dimensions

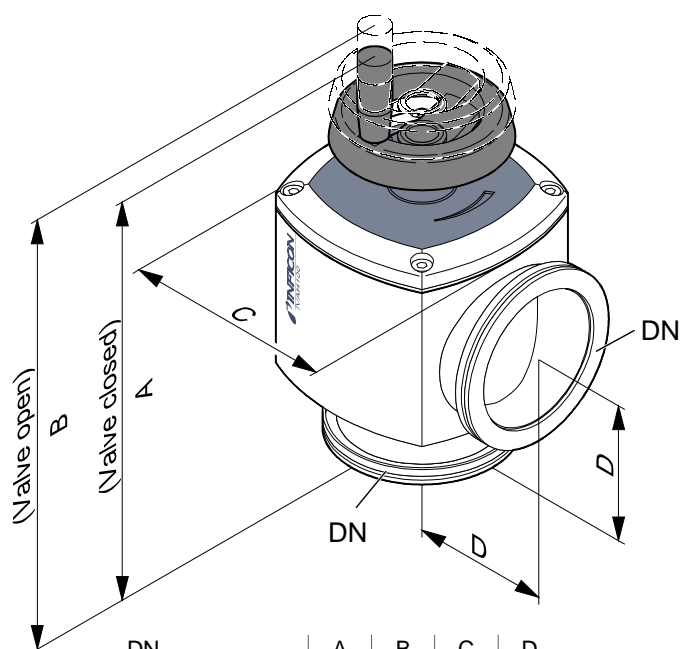

DN	A	B	C	D
DN 63 ISO-K	266	286	124	88
DN 100 ISO-K	320	345	164	108

4 Installation

Personnel qualifications

Skilled personnel

The vacuum connection may only be established by persons who have suitable technical training and the necessary experience or who have been instructed by the end-user of the product.

Dirt sensitive area

Caution

Caution: dirt sensitive area
 Touching the product or parts thereof with bare hands increases the desorption rate.
 Always wear clean, lint-free gloves and use clean tools when working in this area.

Handling of vacuum components

Caution

Caution: vacuum component
 Dirt and damages impair the function of the vacuum component.
 When handling vacuum components, take appropriate measures to ensure cleanliness and prevent damages.

Protective lids

Keep the protective lids.

Vacuum connection

Remove the protective lids and install the valve to the vacuum system by means of the clamping flange fittings.
 Any installation angle and flow direction may be chosen.

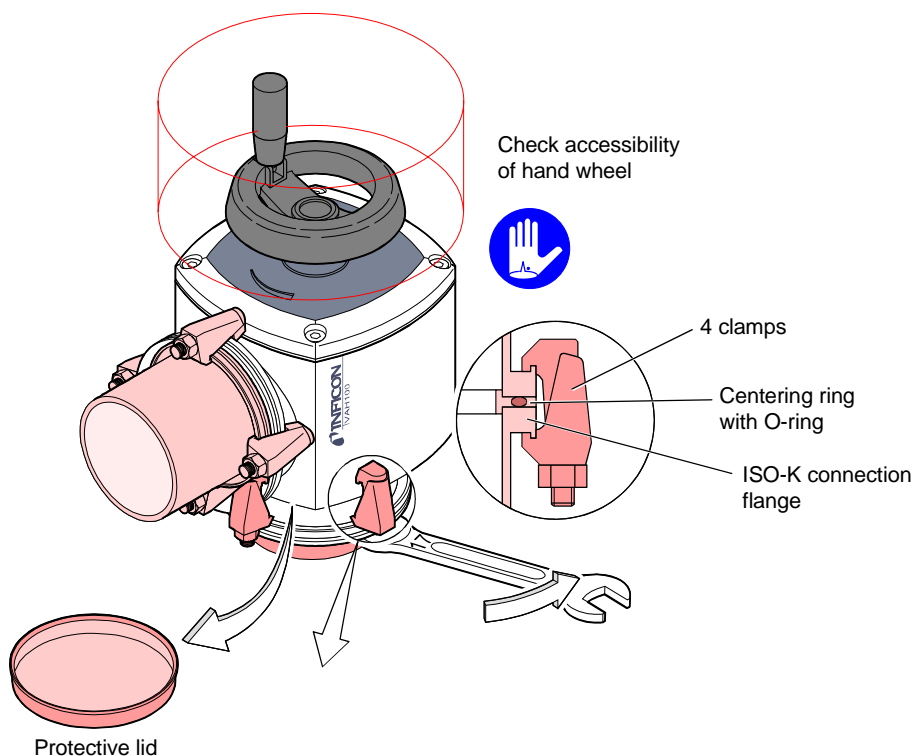

5 Operation

The product is ready for operation as soon as it has been installed.

Operation

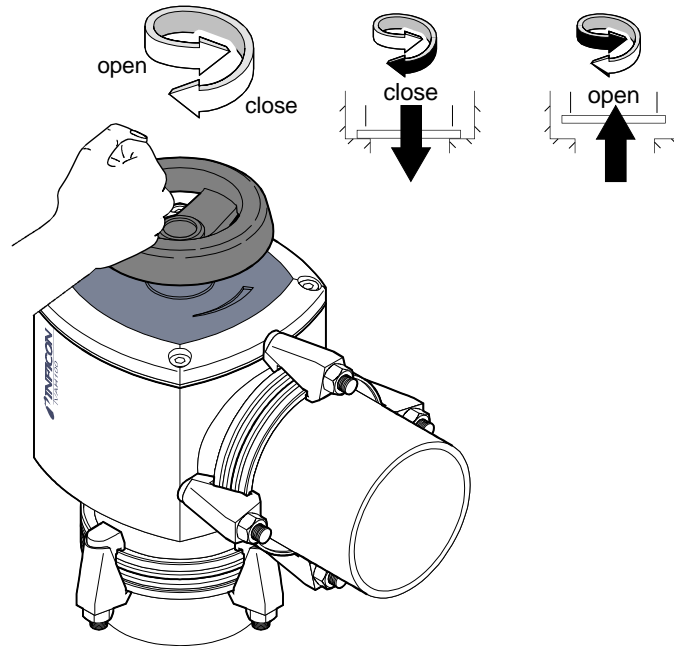

Position indicator

There is a green position indicator under the hand wheel. It is visible when the Angle valve is open.

Pressure range

1×10^{-8} mbar ... 1.5 bar (absolute)

Pressure difference Δp in closing direction

Caution

Caution: pressure difference Δp

At $\Delta p > 1.5$ bar may no longer be tight.
Avoid pressure differences $\Delta p > 1.5$ bar

Pressure difference Δp in opening direction

Caution

Caution: pressure difference Δp

At $\Delta p > 1.5$ bar the valve is opened.
Avoid pressure differences $\Delta p > 1.5$ bar.

Opening against a pressure difference Δp

Caution

Caution: pressure difference Δp

At $\Delta p > 1.5$ bar the valve cannot open.
Avoid pressure differences $\Delta p > 1.5$ bar.

6 Deinstallation

Personnel qualifications

Skilled personnel

The vacuum connection may only be disassembled by persons who have suitable technical training and the necessary experience or who have been instructed by the end-user of the product.

Possible contamination

DANGER

Caution: contaminated parts
Contaminated parts can be detrimental to health and environment.
Before beginning to work, find out whether any parts are contaminated. Adhere to the relevant regulations and take the necessary precautions when handling contaminated parts.

Handling of vacuum components

Caution

Caution: vacuum component
Dirt and damages impair the function of the vacuum component.
When handling vacuum components, take appropriate measures to ensure cleanliness and prevent damages.

Dirt sensitive area

Caution

Caution: dirt sensitive area
Touching the product or parts thereof with bare hands increases the desorption rate.
Always wear clean, lint-free gloves and use clean tools when working in this area.

Vent the vacuum system and disassemble the clamping flange connection. Place the protective lids.

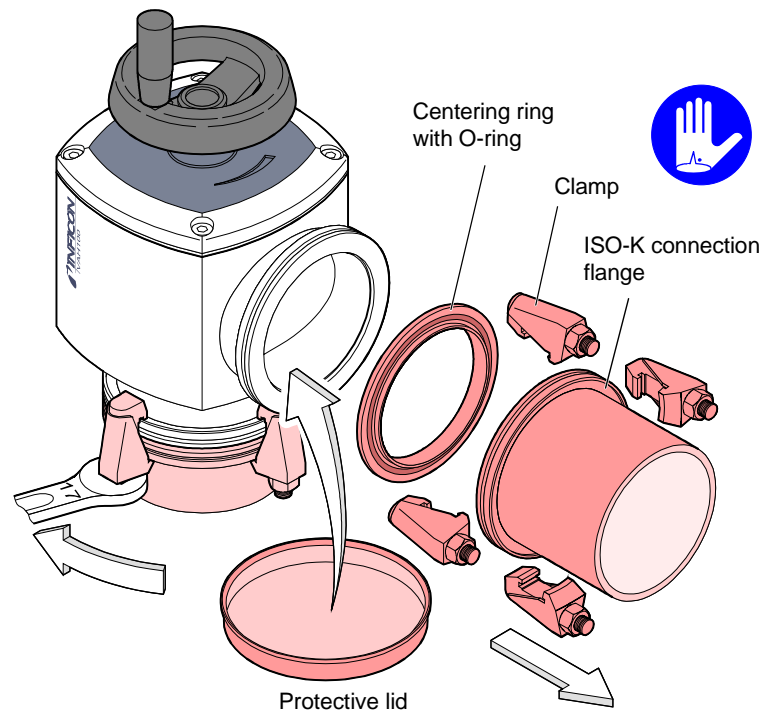

7 Maintenance / Repair

Personnel qualifications

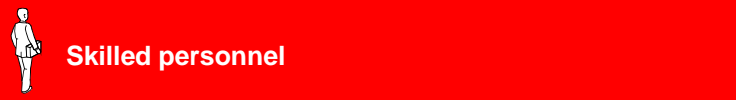

All work described in this document may only be carried out by persons who have suitable technical training and the necessary experience or who have been instructed by the end-user of the product.

Possible contamination



Caution: contaminated parts
Contaminated parts can be detrimental to health and environment. Before beginning to work, find out whether any parts are contaminated. Adhere to the relevant regulations and take the necessary precautions when handling contaminated parts.

Handling of vacuum components



Caution: vacuum component
Dirt and damages impair the function of the vacuum component. When handling vacuum components, take appropriate measures to ensure cleanliness and prevent damages.

Dirt sensitive area



Caution: dirt sensitive area
Touching the product or parts thereof with bare hands increases the desorption rate. Always wear clean, lint-free gloves and use clean tools when working in this area.

Procedure

Maintenance and repair work comprises:

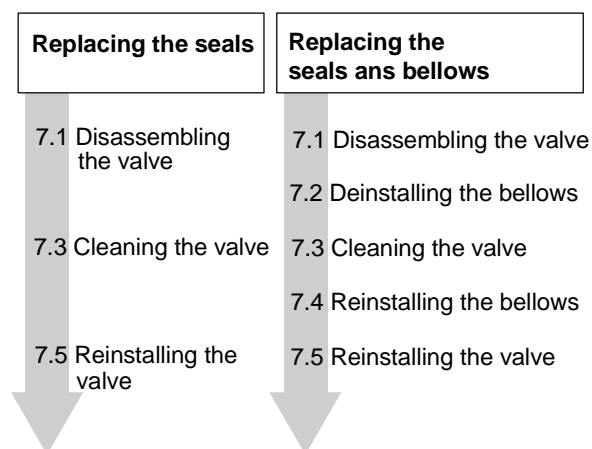

7.1 Disassembling the Valve

- 1 Open the Angle valve in order to relieve the valve plate.

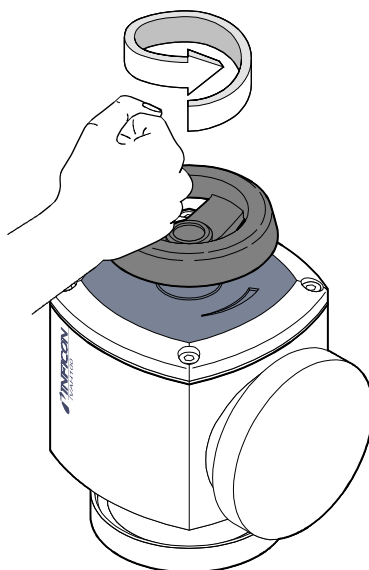

- 2 Unscrew the hex socket screws from the cover.

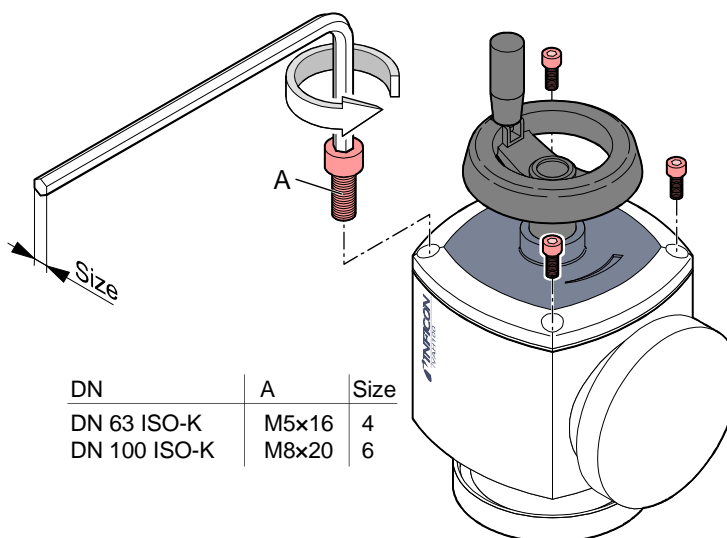

- 3** Carefully remove the spindle drive.

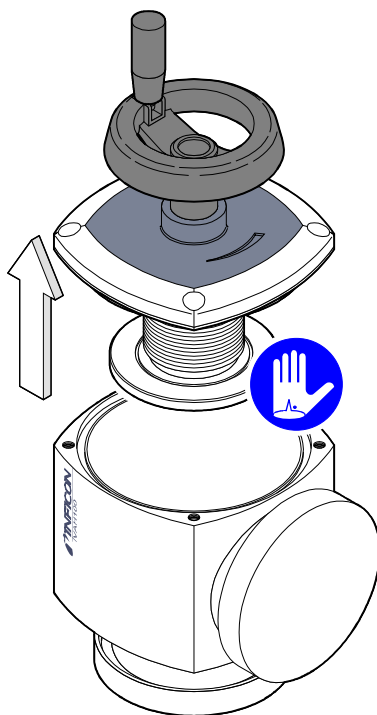

- 4** Remove the O-rings and replace them if necessary.

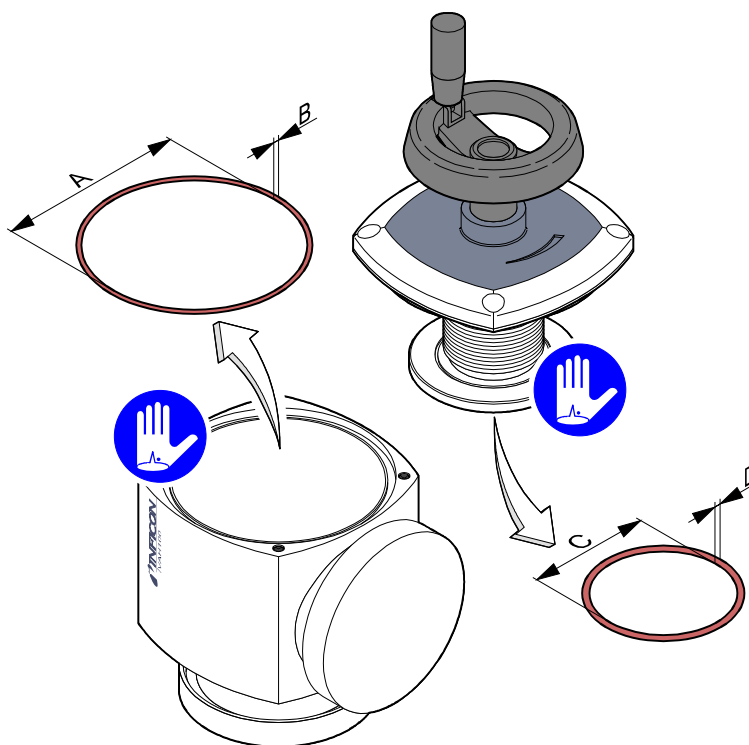

O-ring, FPM	$\varnothing A \times B$	$\varnothing C \times D$
DN 63 ISO-K	$\varnothing 110.72 \times 3.53$	$\varnothing 68 \times 5$
DN 100 ISO-K	$\varnothing 152.00 \times 3.53$	$\varnothing 100 \times 5$

7.2 Deinstalling the Bellows

- 1 Remove the roll pin from the hand wheel.

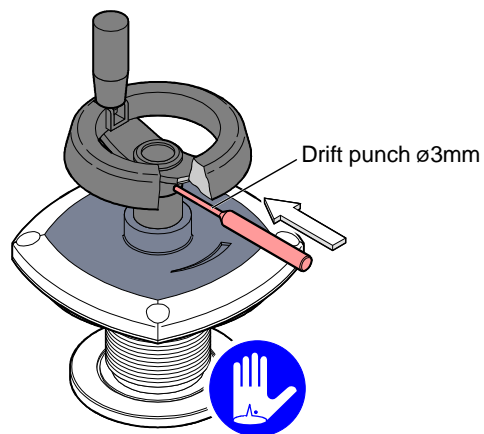

- 2 Remove the hand wheel.

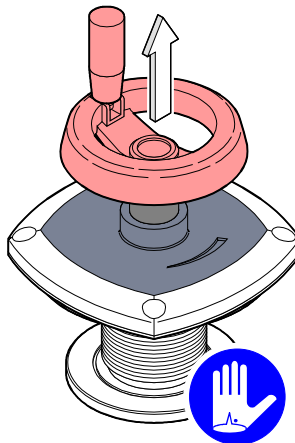

- 3 Remove the position indicator.

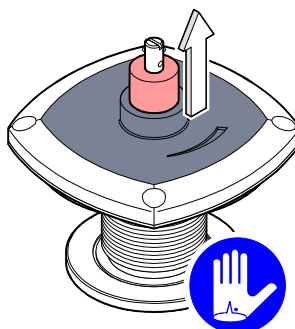

- 4 Screw the spindle out of the cover.

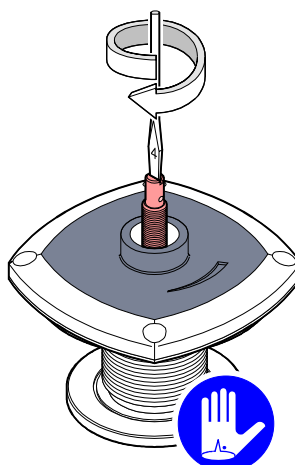

- 5 Remove the cover.

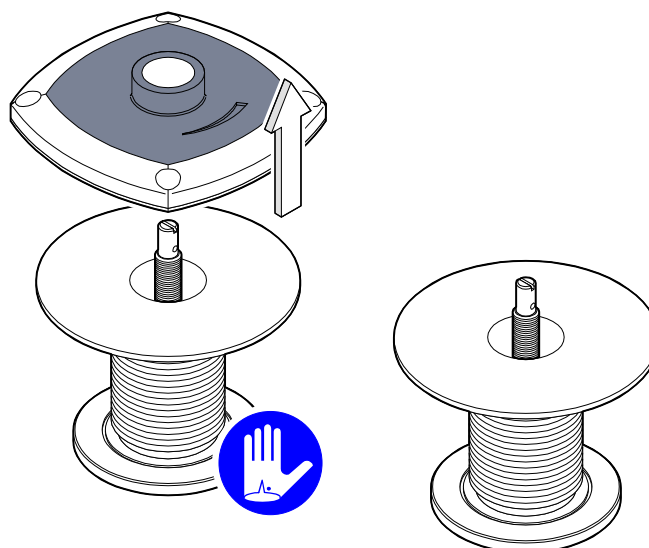

7.3 Cleaning the Valve

DANGER



Caution: cleaning agents

Cleaning agents can be detrimental to health and environment. Adhere to the relevant regulations and take the necessary precautions when handling and disposing of cleaning agents. Consider possible reactions with the product materials (→ 6).

- Carefully clean the parts with a grease solving, non-scouring cleaner.
- After cleaning, the parts should preferably be rinsed with alcohol and subsequently heated to $\approx 50^{\circ}\text{C}$ in an oven or with an industrial blower.
- Carefully clean the sealing surfaces with a lint-free cloth moistened with alcohol. Allow them to dry.

7.4 Reinstalling the Bellows

- 1 Place the cover.

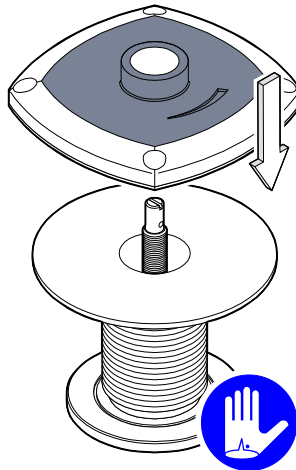

- 2 Screw in the spindle until the stop position is reached.

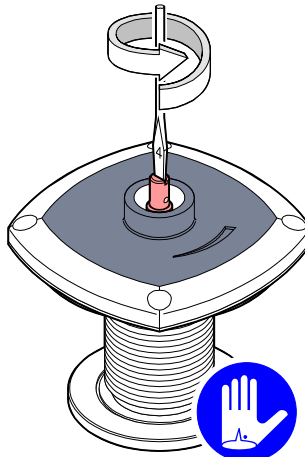

- 3 Install the position indicator.

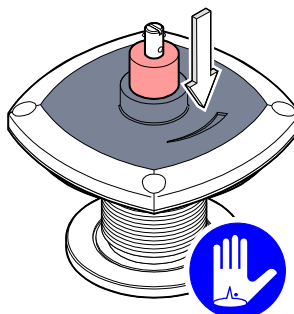

4 Mount the hand wheel.

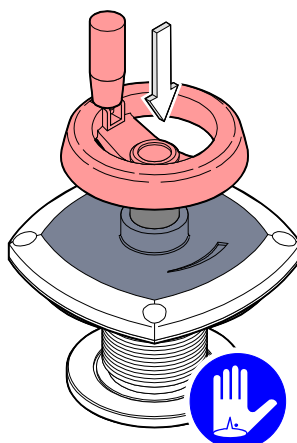

5 Install the roll pin.

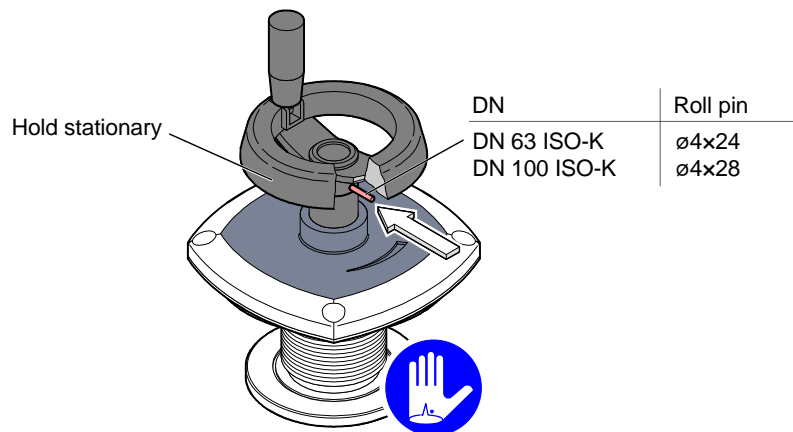

7.5 Reassembling the Valve

1 Install the O-rings.

Caution



Be careful to insert the O-rings level into the grooves without twisting them.

After reassembling the Angle valve, open and close it a few times in order for the O-rings to perfectly adapt to the sealing surfaces.

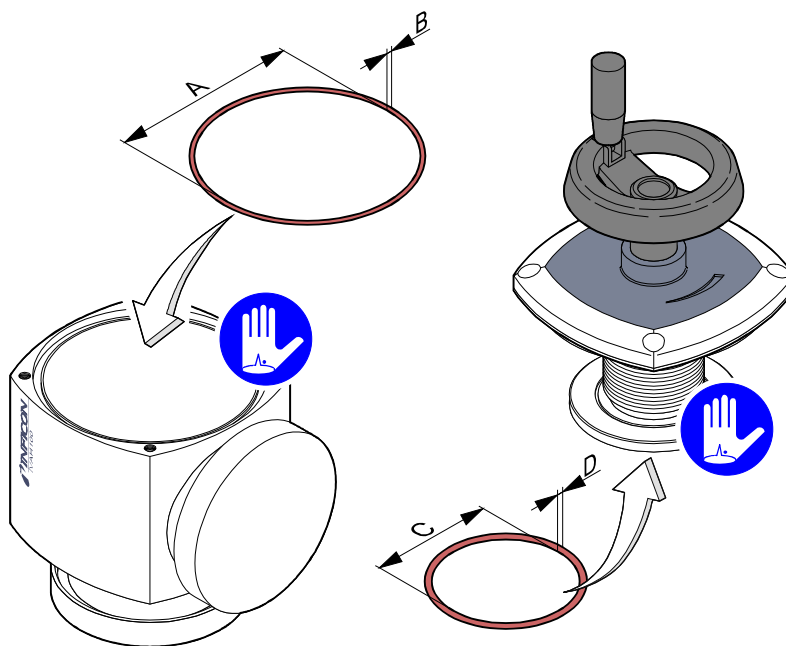

O-ring, FPM	$\varnothing A \times B$	$\varnothing C \times D$
DN 63 ISO-K	$\varnothing 110.72 \times 3.53$	$\varnothing 68 \times 5$
DN 100 ISO-K	$\varnothing 152.00 \times 3.53$	$\varnothing 100 \times 5$

2 Install the spindle drive.

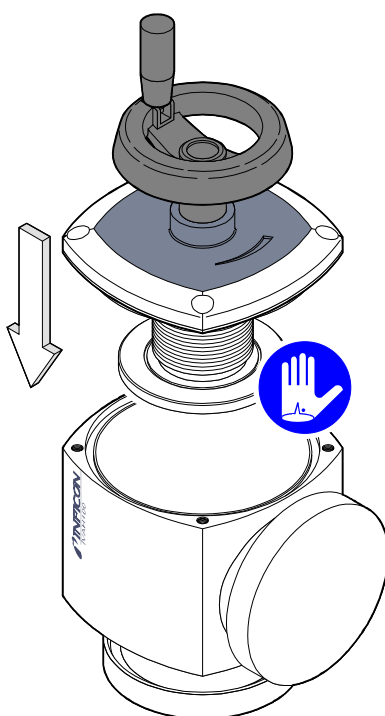

3 Tighten the hex socket screws.

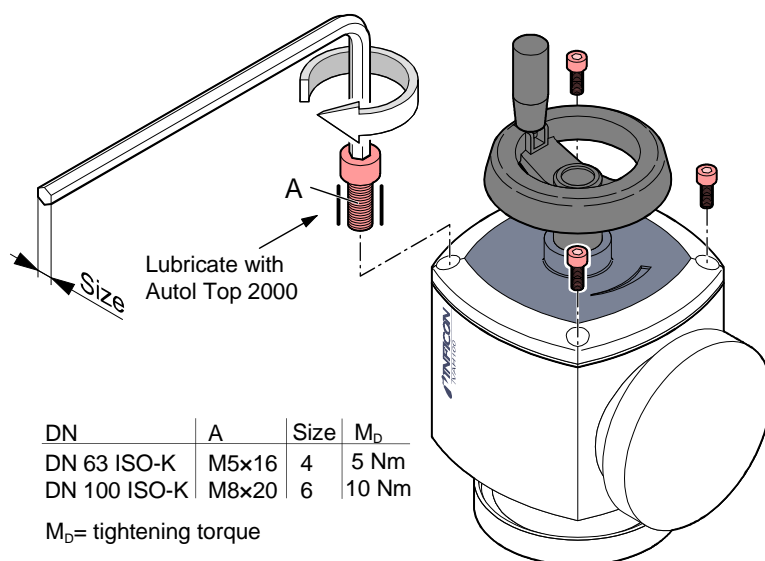

DN	A	Size	M _D
DN 63 ISO-K	M5x16	4	5 Nm
DN 100 ISO-K	M8x20	6	10 Nm

M_D= tightening torque

8 Spare Parts

When ordering spare parts, always indicate:

- all information on the product nameplate
- description and ordering number

Installation of spare parts



Caution



When installing spare parts, adhere to the safety information in section "Maintenance / Repair" (→ 11).

Seal kit

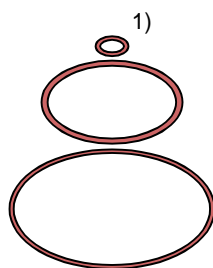

Nominal diameter	Pieces	Description	Dimensions	Ordering number
DN 63 ISO-K	5	O-rings FPM75	ø68x5	215-251
	5	O-rings FPM75	ø110.72x3.53	
	5	Scraper rings	ø18/22.5x4	
DN 100 ISO-K	5	O-rings FPM75	ø100x5	215-271
	5	O-rings FPM75	ø152x3.53	
	5	Scraper rings	ø18/22.5x4	

¹⁾ The scraper ring is not needed for this product.

Bellows kit ¹⁾

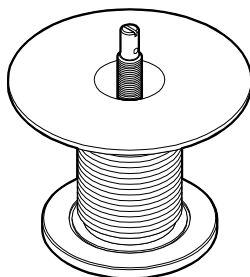

Nominal diameter	Pieces	Description	Ordering number
DN 63 ISO-KF	1	Bellows kit	215-254
DN 100 ISO-KF	1	Bellows kit	215-274

¹⁾ The bellows kit does not include any seals.

9 Returning the Product

Forwarding contaminated products

WARNING

Caution: forwarding contaminated products

Contaminated products (e.g. radioactive, toxic, caustic or micro-biological hazard) can be detrimental to health and environment.

Products returned to Inficon for maintenance, repair, and disposal should preferably be free of harmful substances. Adhere to the forwarding regulations of all involved countries and forwarding companies and enclose a completed declaration of contamination (→ 22).

Products that are not clearly declared as "free of harmful substances" are decontaminated at the expense of the customer.

Products not accompanied by a duly completed declaration of contamination are returned to the sender at his own expense.

10 Disposal

Possible contamination

DANGER

Caution: contaminated parts

Contaminated parts can be detrimental to health and environment.

Before beginning to work, find out whether any parts are contaminated. Adhere to the relevant regulations and take the necessary precautions when handling contaminated parts.

Separating the components

After disassembling the product, separate its components according to the following criteria:

Contaminated components

Contaminated components (radioactive, toxic, caustic, or biological hazard etc.) must be decontaminated in accordance with the relevant national regulations, separated according to their materials, and disposed of.

Other components

Such components must be separated according to their materials and recycled.

Declaration of Contamination

The service, repair, and/or disposal of vacuum equipment and components will only be carried out if a correctly completed declaration has been submitted. Non-completion will result in delay.
 This declaration may only be completed (in block letters) and signed by authorized and qualified staff.

1 Description of product

Type _____

Part number _____

Serial number _____

2 Reason for return

3 Operating fluid(s) used (Must be drained before shipping.)

4 Process related contamination of product:

toxic	no <input type="checkbox"/> 1)	yes <input type="checkbox"/>	
caustic	no <input type="checkbox"/> 1)	yes <input type="checkbox"/>	
biological hazard	no <input type="checkbox"/>	yes <input type="checkbox"/> 2)	
explosive	no <input type="checkbox"/>	yes <input type="checkbox"/> 2)	
radioactive	no <input type="checkbox"/>	yes <input type="checkbox"/> 2)	
other harmful substances	no <input type="checkbox"/> 1)	yes <input type="checkbox"/>	

The product is free of any substances which are damaging to health
 yes

1) or not containing any amount of hazardous residues that exceed the permissible exposure limits

2) Products thus contaminated will not be accepted without written evidence of decontamination!

5 Harmful substances, gases and/or by-products

Please list all substances, gases, and by-products which the product may have come into contact with:

Trade/product name	Chemical name (or symbol)	Precautions associated with substance	Action if human contact

6 Legally binding declaration:

I/we hereby declare that the information on this form is complete and accurate and that I/we will assume any further costs that may arise. The contaminated product will be dispatched in accordance with the applicable regulations.

Organization/company _____

Address _____ Post code, place _____

Phone _____ Fax _____

Email _____

Name _____

Date and legally binding signature _____ Company stamp _____

Original: German sina43d1 (0110)



01 na43d1



*LI-9496 Balzers
Liechtenstein
Tel +423 / 388 3111
Fax +423 / 388 3700
reach.liechtenstein@inficon.com*

www.inficon.com