

Inline Valve

electromagnetically actuated
normally closed

VIM005-X

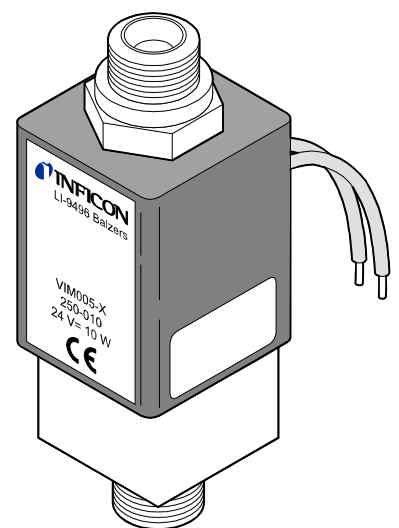

CE

Product Identification

In all communications with INFICON, please specify the information given on the product nameplate. For convenient reference copy that information into the space provided below.

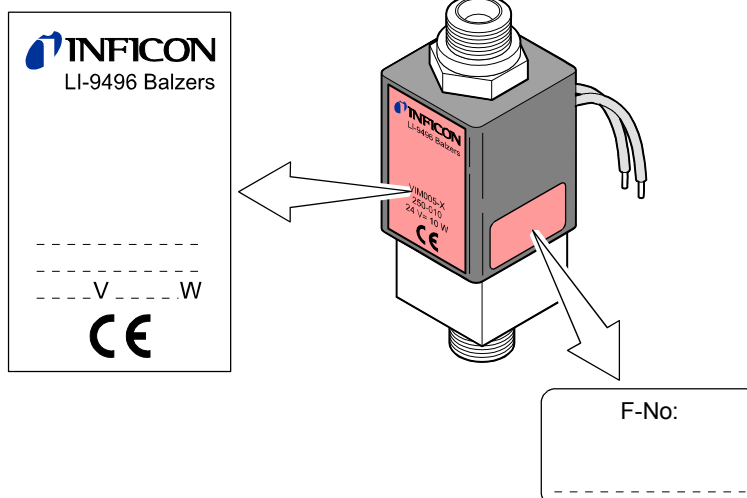

Validity

This document applies to products with part number 250-010.
The part number can be taken from the product nameplate.

We reserve the right to make technical changes without prior notice.

If not indicated otherwise in the illustrations, the dimensions are in mm.

Scope of Delivery

The following parts are included in the scope of delivery:

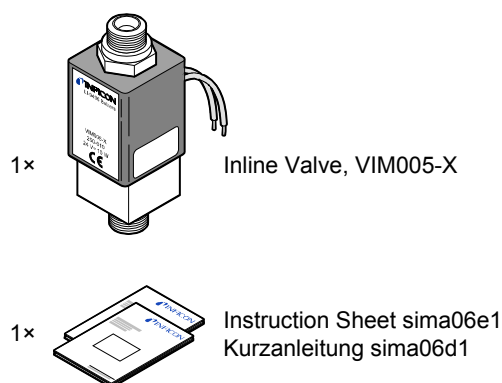

Intended Use

The VIM005-X is predominantly used in fast-cycling vacuum systems, e.g. for gas analysis and coating processes.

Functional Principle

The VIM005-X is opened electromagnetically and closed by the prestressed pressure spring.

It will close, or remain closed, on power loss.

Contents

Product Identification	2
Validity	2
Scope of Delivery	2
Intended Use	3
Functional Principle	3
1 Safety	4
1.1 Symbols Used	4
1.2 Personnel Qualifications	4
1.3 General Safety Instructions	4
1.4 Liability and Warranty	5
2 Technical Data	6
3 Installation	8
3.1 Vacuum Connection	8
3.2 Electrical Connection	10
4 Operation	11
5 Deinstallation	12
6 Maintenance, Repair	13
6.1 Cleaning the Valve, Replacing Parts	13
7 Accessories	15
8 Spare Parts	16
9 Returning the Product	18
10 Disposal	18
Declaration of Contamination	19

1 Safety

1.1 Symbols Used

DANGER

Information on preventing any kind of physical injury.

WARNING

Information on preventing extensive equipment and environmental damage.

Caution

Information on correct handling or use. Disregard can lead to malfunctions or minor equipment damage.



→  See page ...

1.2 Personnel Qualifications

Skilled personnel

All work described in this document may only be carried out by persons who have suitable technical training and the necessary experience or who have been instructed by the end-user of the product.

1.3 General Safety Instructions

- Adhere to the applicable regulations and take the necessary precautions for the process media used.
Consider possible reactions between the materials (→  6) and the process media.
Consider possible reactions of the process media due to the heat generated by the product (→  6).
- Adhere to the applicable regulations and take the necessary precautions for all work you are going to do and consider the safety instructions in this document.
- Before beginning to work, find out whether any vacuum components are contaminated. Adhere to the relevant regulations and take the necessary precautions when handling contaminated parts.

Communicate the safety instructions to all other users.

1.4 Liability and Warranty

INFICON assumes no liability and the warranty becomes null and void if the end-user or third parties

- disregard the information in this document
- use the product in a non-conforming manner
- make any kind of changes (modifications, alterations etc.) to the product
- use the product with accessories not listed in the corresponding product documentation.

The end-user assumes the responsibility in conjunction with the process media used.

2 Technical Data

Version	normally closed
Vacuum connection	ø5 mm / M14×1
Vacuum connection (accessories)	<ul style="list-style-type: none"> • Flange fitting DN 10 ISO-KF • Tube connection OD ¼" • Tube connection OD 6 mm
Nominal voltage	24 VDC ±10%
Nominal power	10 W
Duty cycle	100% (i.e. continuous duty possible)
Protection category	IP 65 according to DIN 40 050
Conductance for air molecular flow	0.2 l/s
laminar flow	2 l/s
Mounting orientation	any
Switching frequency max.	300 / min ¹⁾
Cycles to first overhaul	≈ 2,000,000 ²⁾
Tightness	1×10 ⁻⁹ mbar l/s
Pressure range	1×10 ⁻⁸ mbar ... 10 bar (absolute)
Pressure difference Δp in closing direction	5 bar
in opening direction	1.5 bar
Opens to a pressure difference Δp	1 bar with 24 VDC
Closing time	7 ms ¹⁾
Opening time	30 ms ¹⁾
Temperatures ambiance	5 °C ³⁾ ... 40 °C
heat generation	60 °C (after 1¼ hours on continuous duty)
bakeout with idle coil	120 °C
bakeout without coil	150 °C
Materials housing	stainless steel 1.4301
connection nut	stainless steel 1.4301
actuator	stainless steel 1.4105
seals	FPM
Weight	0.28 kg



¹⁾ At a pressure difference Δp = 0 bar

²⁾ Under clean operating conditions

³⁾ -15 °C, if the ambiance is free of condensable gases

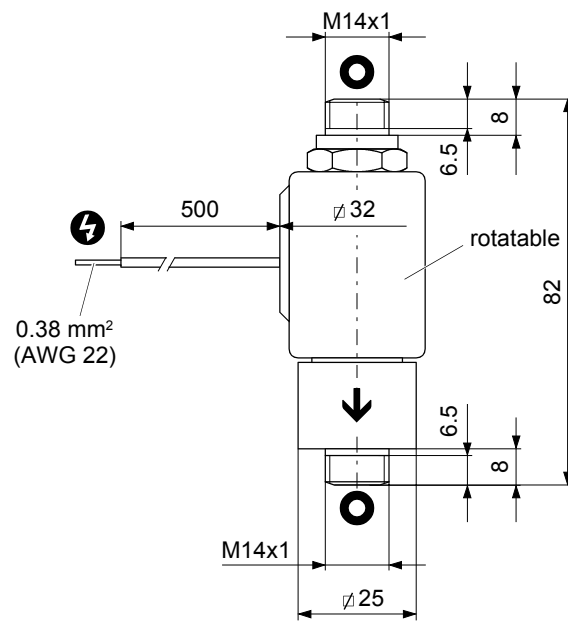
Dimensions [mm]



-  Recommended flow direction
-  Electrical connection
-  Protective lid

Space requirements with accessories
(Accessories → 9)

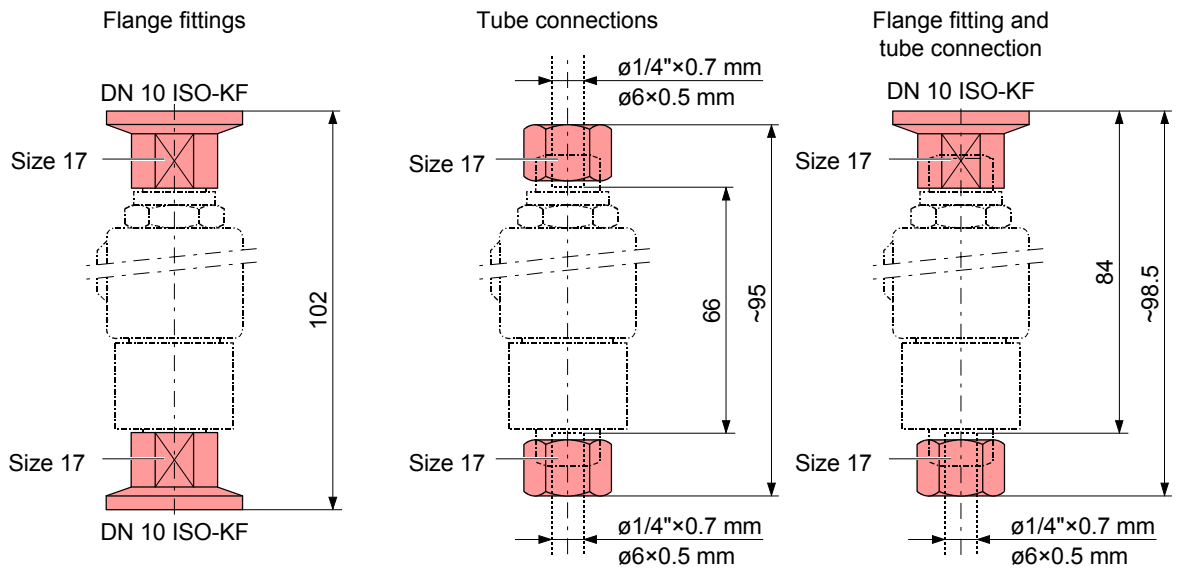

3 Installation

3.1 Vacuum Connection



Caution



Caution: vacuum component
Dirt and damages impair the function of the vacuum component.
When handling vacuum components, take appropriate measures to ensure cleanliness and prevent damages.



Caution



Caution: dirt sensitive area
Touching the product or parts thereof with bare hands increases the desorption rate.
Always wear clean, lint-free gloves and use clean tools when working in this area.



Remove the protective lids.

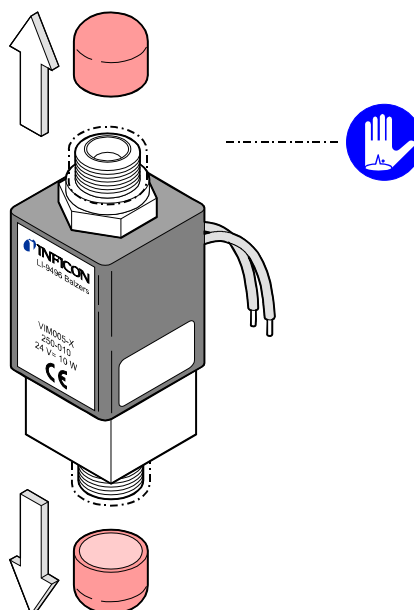

Keep the protective lids.

2 Mount the valve to the vacuum system using an accessory.

Caution



Caution: tightening torque applied to connection nut
 If a torque >3 Nm is applied to the connection nut, the solenoid coil is destroyed.

Apply a torque ≤ 3 Nm to the connection nut and hold either the connection nut or the valve housing stationary while tightening the vacuum connection.

Hold the connection nut stationary.

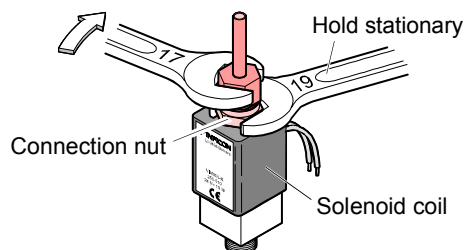

Hold the housing stationary.

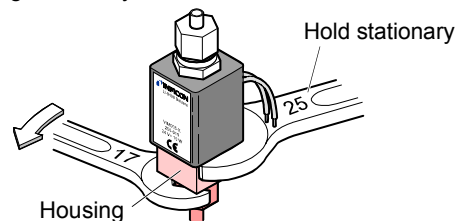

Accessories
 (1 piece per part number)

Flange fitting
 DN 10 ISO-KF

Part No. 250-080

Tube connection
 OD 1/4"

$\varnothing 1/4" \times 0.7$ mm

Part No. 250-085

Tube connection
 OD 6 mm

$\varnothing 6 \times 0.5$ mm

Part No. 250-086

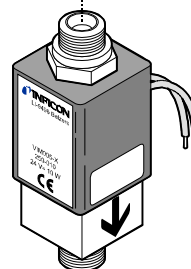

↓ Flow direction

Flange fitting
 DN 10 ISO-KF

Part No. 250-080

Tube connection
 OD 1/4"

$\varnothing 1/4" \times 0.7$ mm

Part No. 250-085

Tube connection
 OD 6 mm

$\varnothing 6 \times 0.5$ mm

Part No. 250-086

See separate document for installation of the accessories.
 Space requirements with accessories → 7.

3.2 Electrical Connection

The electrical connection is established via the two cable strands. Adhere to the local regulations with regard to the installation.

Caution

Caution: switching of inductive loads (solenoid coil)
 Inductive loads may considerably reduce the life of or even destroy contacts.
 Preferably a clamping diode should be connected in parallel to the solenoid coil. The polarity should be chosen in such a way that the diode blocks when the normal operating voltage is applied.



Before connecting or disconnecting the product, turn off the control system.

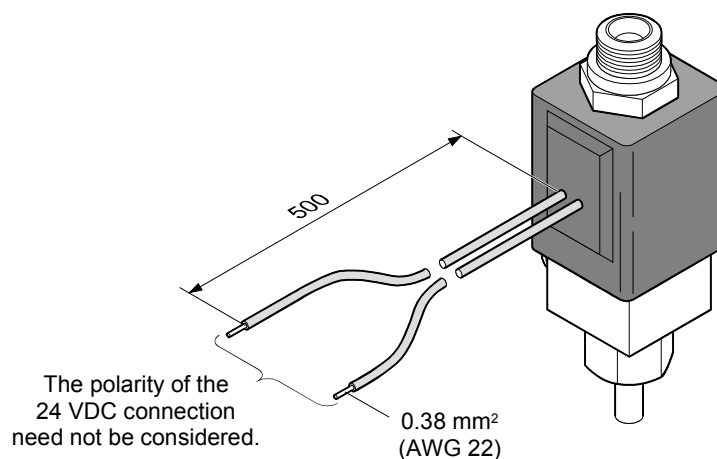

4 Operation

The product is ready for operation as soon as it has been installed.

The VIM005-X will close, or remain closed, on power loss.

DANGER



Caution: hot surface
Touching the hot surface ($>55\text{ }^{\circ}\text{C}$) can cause burns.
Wear protective gloves.

Pressure difference Δp in closing direction



Caution

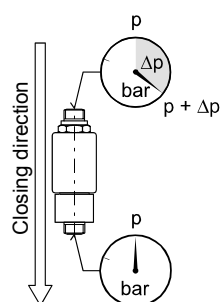

Caution: pressure difference
With $\Delta p > 5\text{ bar}$ the O-ring of the valve plate can get damaged.
Avoid pressure differences $\Delta p > 5\text{ bar}$.

Pressure difference Δp in opening direction



Caution

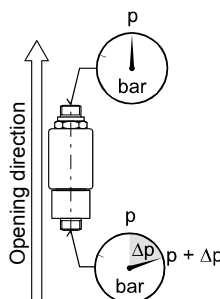

Caution: pressure difference
With $\Delta p > 1.5\text{ bar}$ the valve is opened.
Avoid pressure differences $\Delta p > 1.5\text{ bar}$.

Maximum pressure difference Δp for opening



Caution

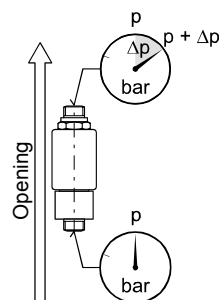

Caution: pressure difference
With $\Delta p > 1\text{ bar}$ the valve cannot open.
Avoid pressure differences $\Delta p > 1\text{ bar}$.

5 Deinstallation

DANGER



Caution: contaminated parts

Contaminated parts can be detrimental to health.

Before beginning to work, find out whether any parts are contaminated. Adhere to the relevant regulations and take the necessary precautions when handling contaminated parts.

Caution



Caution: vacuum component

Dirt and damages impair the function of the vacuum component.

When handling vacuum components, take appropriate measures to ensure cleanliness and prevent damages.

Caution



Caution: dirt sensitive area

Touching the product or parts thereof with bare hands increases the desorption rate.

Always wear clean, lint-free gloves and use clean tools when working in this area.

Preconditions

- Vacuum system vented
- Control system disconnected from the power source
- Valve cooled down to <math>< 55\text{ }^\circ\text{C}</math>

Procedure

- 1 Disconnect the product from the power source.
- 2 Disconnect the product from the vacuum system and install the protective lids.

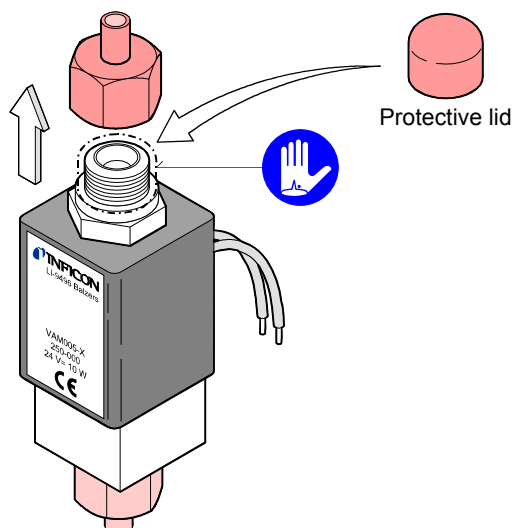

6 Maintenance, Repair

Under clean operating conditions the product requires no maintenance during the rated cycle life.



Failures due to contamination or wear and tear are not covered by the warranty.

DANGER



Caution: contaminated parts

Contaminated parts can be detrimental to health.

Before beginning to work, find out whether any parts are contaminated. Adhere to the relevant regulations and take the necessary precautions when handling contaminated parts.

Caution



Caution: vacuum component

Dirt and damages impair the function of the vacuum component.

When handling vacuum components, take appropriate measures to ensure cleanliness and prevent damages.

6.1 Cleaning the Valve, Replacing Parts

Precondition

Valve disconnected from the vacuum system (→ 12)

Disassembling the valve



Unfasten and remove the connection nut.

Caution



When reinstalling the product, tighten the connection with a maximum torque of 3 Nm. Otherwise the solenoid coil is destroyed.

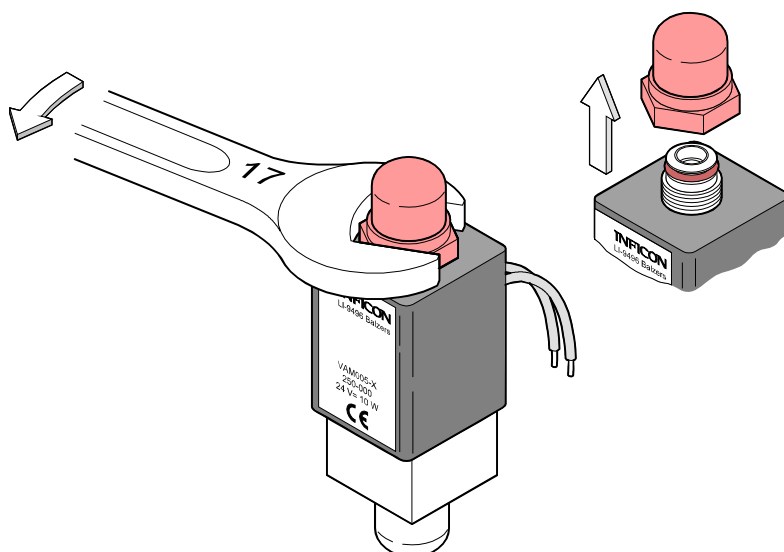

2 Remove the solenoid coil.

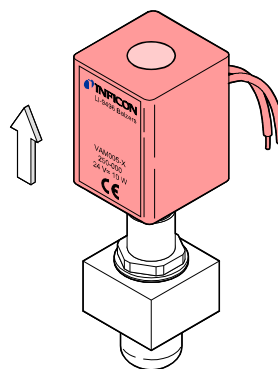

3 Unscrew the guiding tube and disassemble it.

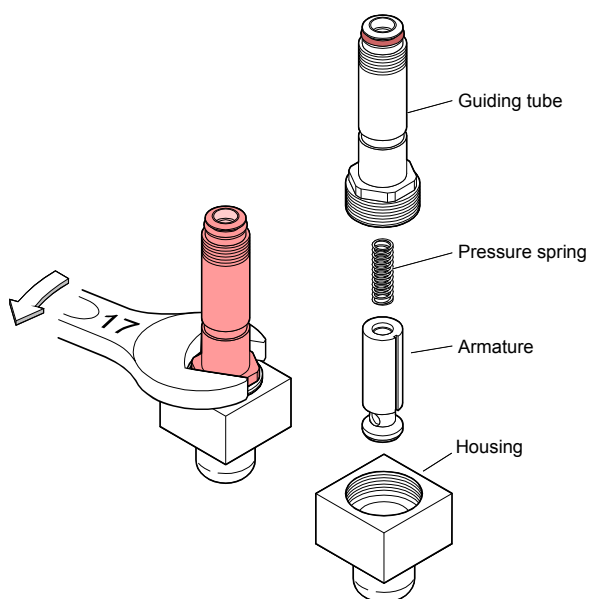

4 Remove the O-rings.



When reassembling the product, be careful to insert the O-rings level into the grooves without twisting them.

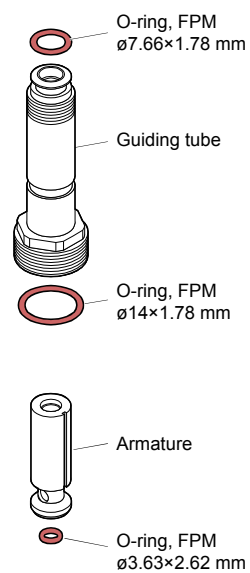

Cleaning the valve

5 Clean the valve.

DANGER

Caution: cleaning agents
 Cleaning agents can be detrimental to health and environment. Adhere to the relevant regulations and take the necessary precautions when handling and disposing of cleaning agents. Consider possible reactions with the product materials (→ 6).

- Clean the parts with a grease-solving, non-scouring cleaning agent.
- After cleaning, the parts should preferably be rinsed with alcohol and subsequently heated to $\approx 50^{\circ}\text{C}$ in an oven or with an industrial blower.
- Clean the sealing surfaces with a lint-free cloth moistened with alcohol. Allow them to dry.
- Wipe the O-rings with a lint-free cloth which has been slightly moistened with vacuum oil.

Reassembly

6 Proceed in reverse order to reassemble the product.



After reassembly, a few switching cycles should be performed in order for the O-rings to perfectly adapt to the sealing surfaces. Take the necessary precautions for this procedure.

7 Accessories

→ 9

8 Spare Parts

When ordering spare parts, always indicate:

- all information on the nameplate
- description and ordering number according to the spare parts list

Spare parts kit

Ordering number 215-366
comprising:

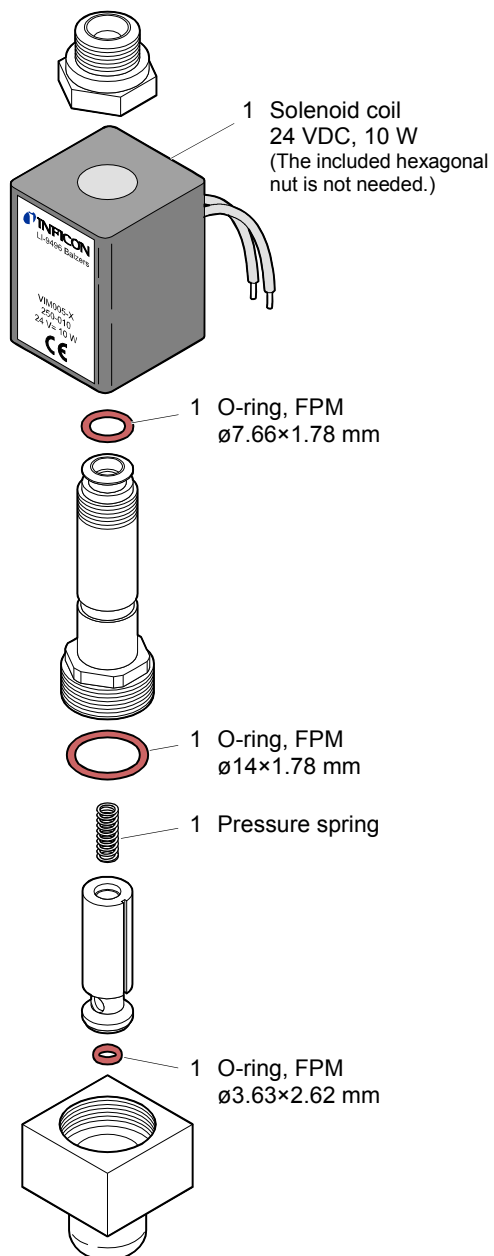

Seal kit

Ordering number 215-371
comprising:

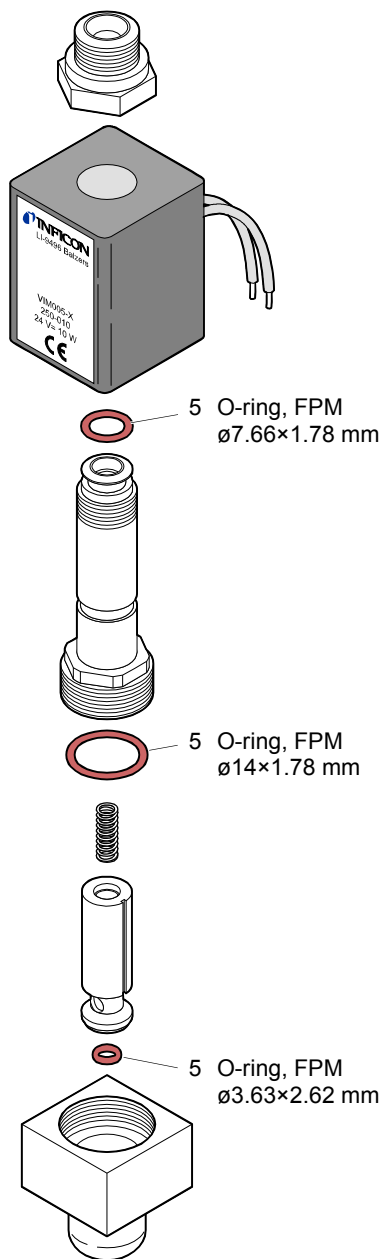

~~5 O-ring, FPM~~
~~ø1.78×1.78 mm~~ **Not** required for this valve

9 Returning the Product

WARNING

Caution: forwarding contaminated products

Contaminated products (e.g. radioactive, toxic, caustic or microbiological hazard) can be detrimental to health and environment.

Products returned to Inficon should preferably be free of harmful substances. Adhere to the forwarding regulations of all involved countries and forwarding companies and enclose a duly completed declaration of contamination (→ 19).

Products that are not clearly declared as "free of harmful substances" are decontaminated at the expense of the customer.

Products not accompanied by a duly completed declaration of contamination are returned to the sender at his own expense.

10 Disposal

DANGER

Caution: contaminated parts

Contaminated parts can be detrimental to health and environment.

Before beginning to work, find out whether any parts are contaminated. Adhere to the relevant regulations and take the necessary precautions when handling contaminated parts.

WARNING

Caution: substances detrimental to the environment

Products or parts thereof (mechanical and electric components, operating fluids etc.) can be detrimental to the environment.

Dispose of such substances in accordance with the relevant local regulations.

Separating the components

After disassembling the product, separate its components according to the following criteria:

Contaminated components

Contaminated components (radioactive, toxic, caustic, or biological hazard etc.) must be decontaminated in accordance with the relevant national regulations, separated according to their materials, and disposed of.

Other components

Such components must be separated according to their materials and recycled.

Original: German sina06d1 (0210)



01 n0261



LI-9496 INFICON

Liechtenstein

Tel +423 / 388 3111

Fax +423 / 388 3700

reach.liechtenstein@inficon.com

www.inficon.com