

# Angle Valve

DN 16 ... 63 CF  
manually operated  
bellows sealed  
Viton valve seat seal

VAH016 ... 063-Z

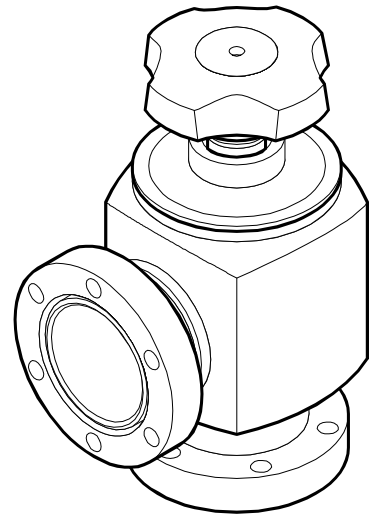

CE

## Product Identification

In all communications with Inficon, please specify the information on the product nameplate. For convenient reference copy that information into the space provided below.

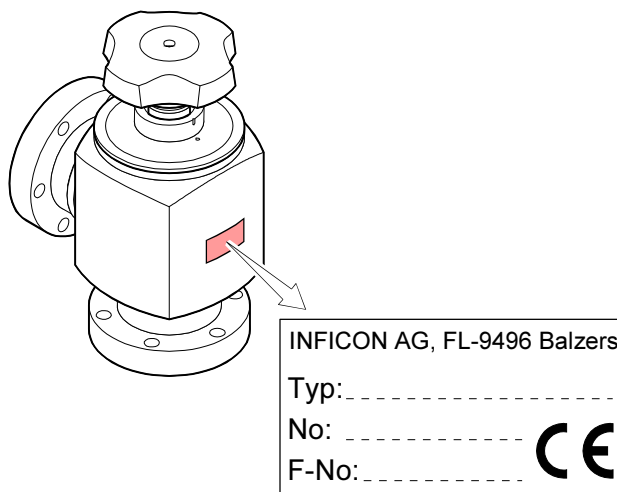

## Validity

This document applies to products with part numbers

250-731 (VAH016-Z DN 016 CF)  
 250-736 (VAH040-Z DN 040 CF)  
 250-741 (VAH063-Z DN 063 CF)

The part number can be taken from the product nameplate.

## Illustrations

If not indicated otherwise in the legends, the illustrations in this document apply to valves with the nominal diameter DN 040. They apply to valves with other nominal diameters by analogy.

## Technical changes

We reserve the right to make technical changes without prior notice.

## Intended Use

The product is used as shut-off valve for UHV and HV applications. It can be baked out at 180 °C. The welded housing is suited for high-purity and toxic gases.

# Contents

Product Identification	2
Validity	2
Intended Use	2
<b>1 Description</b>	<b>4</b>
1.1 Overview	4
1.2 Functional Principle	4
<b>2 Safety</b>	<b>4</b>
2.1 Symbols Used	4
2.2 Personnel Qualifications	5
2.3 General Safety Instructions	5
2.4 Liability and Warranty	5
<b>3 Technical Data</b>	<b>6</b>
<b>4 Installation</b>	<b>8</b>
4.1 Installation	8
4.1.1 Space Requirements	8
4.1.2 Flange Connection	9
<b>5 Start-Up</b>	<b>10</b>
5.1 Bakeout	10
5.2 Bringing the Valve Plate Into the Defined Position	11
<b>6 Operation</b>	<b>11</b>
6.1 Closing the Angle Valve	12
6.2 Opening the Angle Valve	13
6.3 Installing/Removing the Rotary Knob	13
<b>7 Deinstallation</b>	<b>14</b>
<b>8 Maintenance</b>	<b>15</b>
8.1 Bakeout	15
8.2 Replacing the O-Ring of the Valve Plate	15
8.2.1 Deinstalling the Valve Plate	15
8.2.2 Replacing the O-Ring of the Valve Plate	17
8.2.3 Reinstalling the Valve Plate	18
8.3 Cleaning the Angle Valve	19
8.4 Actuator	19
8.5 Leak Detection	19
<b>9 Repair</b>	<b>20</b>
<b>10 Spare Parts</b>	<b>20</b>
<b>11 Accessories</b>	<b>21</b>
<b>12 Storage</b>	<b>21</b>
<b>13 Returning the Product</b>	<b>21</b>
<b>14 Disposal</b>	<b>22</b>
<b>Declaration of Contamination</b>	<b>23</b>

# 1 Description

## 1.1 Overview

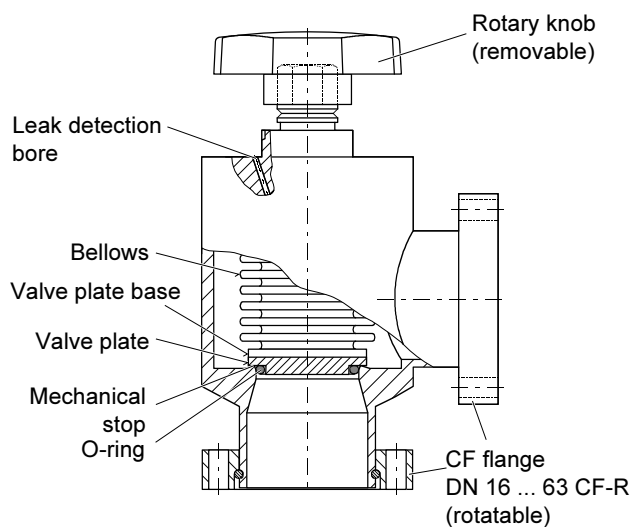

## 1.2 Functional Principle

The sealing effect is achieved by pressing an O-ring against an oblique sealing surface. The valve housing is welded.

# 2 Safety

## 2.1 Symbols Used

**DANGER**

Information on preventing any kind of physical injury.

**WARNING**

Information on preventing extensive equipment and environmental damage.

**Caution**

Information on correct handling or use. Disregard can lead to malfunctions or minor equipment damage.

→ See page ...

## 2.2 Personnel Qualifications



### Skilled personnel

All work described in this document may only be carried out by persons who have suitable technical training and the necessary experience or who have been instructed by the end-user of the product.

## 2.3 General Safety Instructions

- Adhere to the applicable regulations and take the necessary precautions for the process media used.  
Consider possible reactions between the materials (→ 6) and the process media.
- Adhere to the applicable regulations and take the necessary precautions for all work you are going to do and consider the safety instructions in this document.
- Before beginning to work, find out whether any vacuum components are contaminated. Adhere to the relevant regulations and take the necessary precautions when handling contaminated parts.

Communicate the safety instructions to all other users.

## 2.4 Liability and Warranty

Inficon assumes no liability and the warranty becomes null and void if the end-user or third parties

- disregard the information in this document
- use the product in a non-conforming manner
- make any kind of interventions (modifications, alterations etc.) on the product
- use the product with accessories not listed in the corresponding product documentation.

The end-user assumes the responsibility in conjunction with the process media used.

### 3 Technical Data

Connection flanges, rotatable VAH016-Z VAH040-Z VAH063-Z	DN 16 CF-R DN 40 CF-R DN 63 CF-R
Installation angle	any
Flow direction	any
Tightness	$1 \times 10^{-10}$ mbarl/s
Pressure range	$1 \times 10^{-10}$ mbar ... 4 bar (absolute)
Bursting pressure	8 bar
Conductance VAH016-Z VAH040-Z VAH063-Z	3 l/s 38 l/s 100 l/s
Temperatures ambience operation bakeout without rotary knob with rotary knob rotary knob continuous temporary storage	0 °C ... 55 °C $\leq 180$ °C $\leq 180$ °C $\leq 80$ °C $\leq 80$ °C 80 ... 110 °C +5 ... +45 °C -15 ... +45 °C <sup>1)</sup>
Temperature increase VAH016-Z VAH040-Z VAH063-Z	$\leq 4$ °C/minute $\leq 4$ °C/minute $\leq 4$ °C/minute
Closing torque VAH016-Z VAH040-Z VAH063-Z	$\leq 1.0$ Nm $\leq 1.8$ Nm $\leq 2.5$ Nm
Service life O-ring cold closing operations	50,000 cycles
Lift (opening) VAH016-Z VAH040-Z VAH063-Z	12 mm 23 mm 33 mm
Materials housing spindle spindle flange bellows valve plate base valve plate sealing plate O-ring rotary knob	stainless steel 1.4301 CuSn8 2.1030.26 stainless steel 1.4301 stainless steel 1.4541 stainless steel 1.4301 ESU  stainless steel 1.4301 FPM75 PA 15% GF
Weight VAH016-Z VAH040-Z VAH063-Z	0.35 kg 1.8 kg 4.8 kg

<sup>1)</sup> Ambience free of condensable gases.



## 4 Installation



### Caution



Caution: vacuum component

Dirt and damages impair the function of the vacuum component.

When handling vacuum components, take appropriate measures to ensure cleanliness and prevent damages.



### Caution



Caution: dirt sensitive area

Touching the product or parts thereof with one's bare hands increases the desorption rate.

Always wear clean, lint-free gloves and use clean tools when working in this area.

- The valve is delivered in closed condition and with the rotary knob installed.
- The protective packaging should not be removed until shortly before installation. Even the slightest contamination could cause leaks.

## 4.1 Installation

### 4.1.1 Space Requirements

Make sure the valve can be operated without any risk of bodily injury.

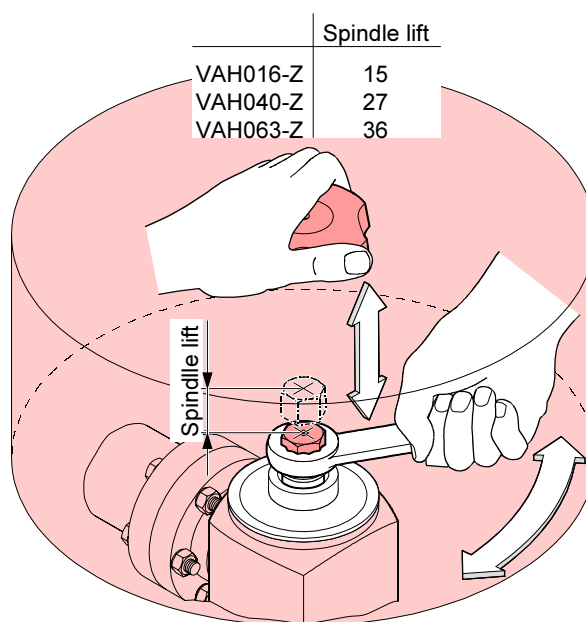

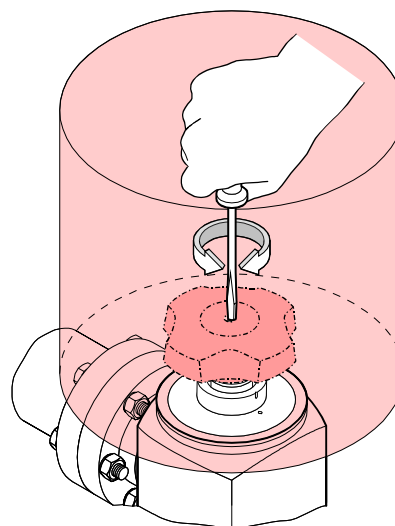

### 4.1.2 Flange Connection

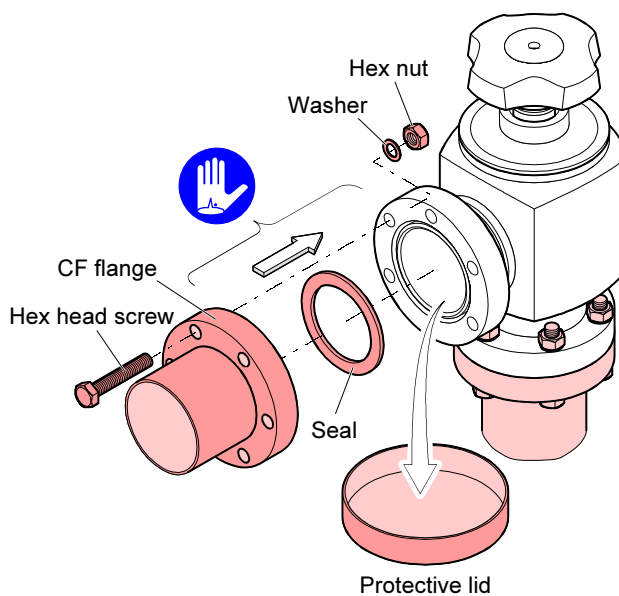

Keep the protective lids.

Flange seals  
(Accessories → 21)

Flange	Seal	Pieces	Ordering number
DN 16 CF	Copper	10	213-371
DN 40 CF	Copper	10	213-372
DN 63 CF	Copper	10	213-373

Screws (Accessories → 21)/  
Torque

Flange	Hex head screw	Number of screws	Required torque
DN 16 CF	M4 × 20 mm	6 per flange	4 Nm
DN 40 CF	M6 × 35 mm	6 per flange	10 Nm
DN 63 CF	M8 × 50 mm	8 per flange	20 Nm

## 5 Start-Up

### 5.1 Bakeout

It is good practice to bake out new valves and valves the inner parts of which have been exposed to atmosphere for some time, e.g. with a heating jacket.

**DANGER**

Caution: hot surface  
Touching the hot surface (>55 °C) can cause burns.  
Do not touch the hot surface.

**Caution**

Caution: bakeout at atmosphere  
Bakeout with the inner parts of the valve exposed to atmosphere may lead to the formation of oxides and thus cause leaks.  
Bake out the valve only if

- the pressure in the vacuum system is  $<1 \times 10^{-4}$  mbar or
- the vacuum system has been vented with inert gas.

**1** Prior to baking the valve at temperatures  $>80$  °C, remove the rotary knob (→ 14).

**2** Bake the valve out.

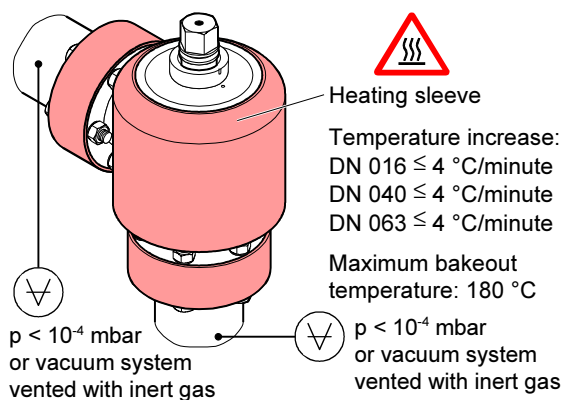

**3** If the rotary knob has been removed, wait until the valve has cooled down ( $<50$  °C) and reinstall the rotary knob (→ 13).

## 5.2 Bringing the Valve Plate Into the Defined Position

Close the valve by turning the rotary knob until the stop position is reached.

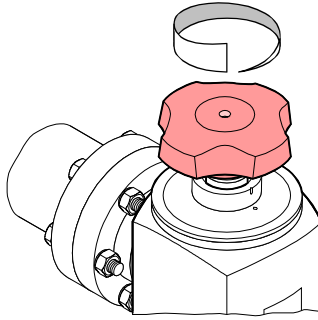

The valve is closed and ready for use now.

## 6 Operation

Prevent the entry of dirt, dust, or other abrasive contamination into the valve. Even very small particles on the sealing surfaces may cause leaks.

**DANGER**



Caution: hot surface  
Touching the hot surface (>55 °C) can cause burns.  
Wear protective gloves.

**Caution**



Caution: bakeout at atmosphere  
Bakeout with the inner parts of the valve exposed to atmosphere may lead to the formation of oxides and thus cause leaks.  
Bake out the valve only if

- the pressure in the vacuum system is  $<1 \times 10^{-4}$  mbar or
- the vacuum system has been vented with inert gas.

## 6.1 Closing the Angle Valve

Depending on the operating temperature, close the angle valve with the rotary knob or a ring wrench.

Operating temperature  $\leq 55\text{ }^{\circ}\text{C}$

Close the valve by turning the rotary knob clockwise until the stop position is reached.

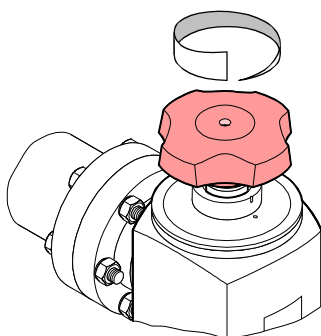

Operating temperature  $> 55\text{ }^{\circ}\text{C}$

Precondition: rotary knob removed.



### Caution



Caution: excessive closing force

Only little force is required to close the valve. If the hex head is turned beyond the stop position, the sealing surfaces and/or the spindle may get damaged.

Do not turn the hex head beyond the mechanical stop.

Close the valve by turning the ring wrench clockwise until the stop position is reached. Remove the ring wrench.



Use the ring wrench only temporarily.

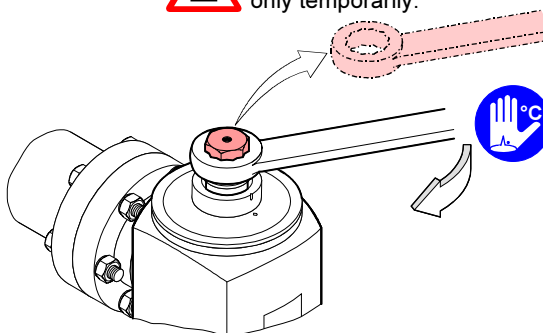

## 6.2 Opening the Angle Valve

Depending on the operating temperature, open the valve with the rotary knob or a ring wrench. The maximum opening of the valve is limited by a mechanical stop.

Operating temperature  $\leq 55$  °C

Open the valve by turning the rotary knob counter-clockwise.

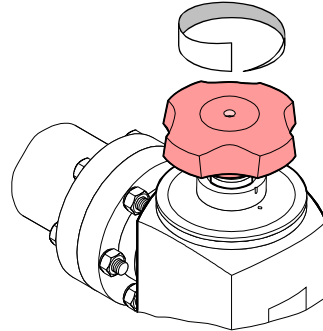

Operating temperature  $> 55$  °C

Precondition: rotary knob deinstalled.

Open the valve by turning the ring wrench counter-clockwise. Remove the ring wrench.

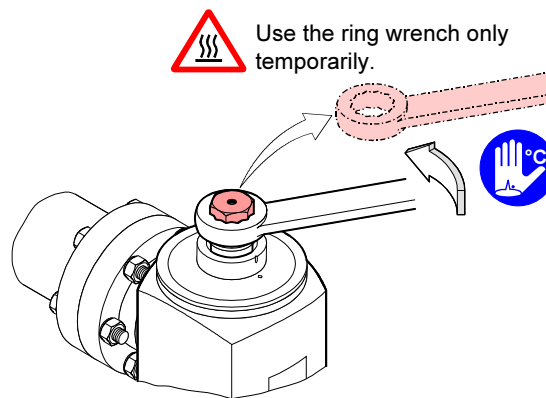

## 6.3 Installing/Removing the Rotary Knob

Using a screwdriver (size 4 mm), loosen/fasten the screw.

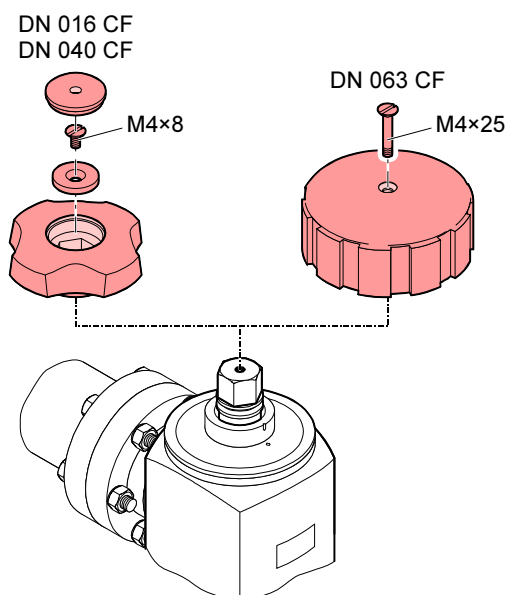

## 7 Deinstallation

### DANGER



Caution: contaminated parts

Contaminated parts can be detrimental to health and environment.

Before beginning to work, find out whether any parts are contaminated. Adhere to the relevant regulations and take the necessary precautions when handling contaminated parts.

### Caution



Caution: vacuum component

Dirt and damages impair the function of the vacuum component.

When handling vacuum components, take appropriate measures to ensure cleanliness and prevent damages.



Vent the vacuum system and wait until the valve has cooled down to <math>< 50\text{ }^\circ\text{C}</math>.

Detach the flanges and put the protective lids in place.

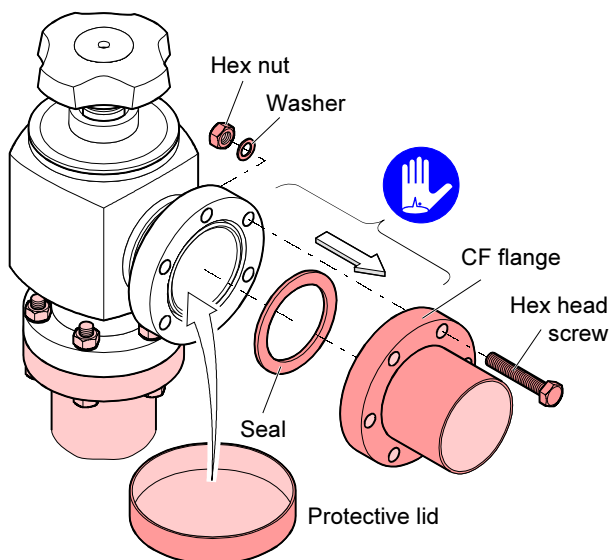

When the valve is reinstalled, replacing the seals is recommended (→ 9).

## 8 Maintenance

### 8.1 Bakeout

The valve is baked in order for its inner parts to be degassed. Undesirable gases can thus be pumped. The pumping time is reduced and the final pressure is reached faster.

It is good practice to bake out valves after cleaning (→ 19) and when their inner parts have been exposed to atmosphere for some time, e.g. with a heating jacket (→ 10).

### 8.2 Replacing the O-Ring of the Valve Plate



**DANGER**

Caution: contaminated parts

Contaminated parts can be detrimental to health and environment.

Before beginning to work, find out whether any parts are contaminated. Adhere to the relevant regulations and take the necessary precautions when handling contaminated parts.



**Caution**

Caution: dirt sensitive area

Touching the product or parts thereof with one's bare hands increases the desorption rate.

Always wear clean, lint-free gloves and use clean tools when working in this area.

The O-ring can only be replaced when the valve is deinstalled (→ 14).

#### 8.2.1 Deinstalling the Valve Plate



1 Open the valve until the stop position is reached.

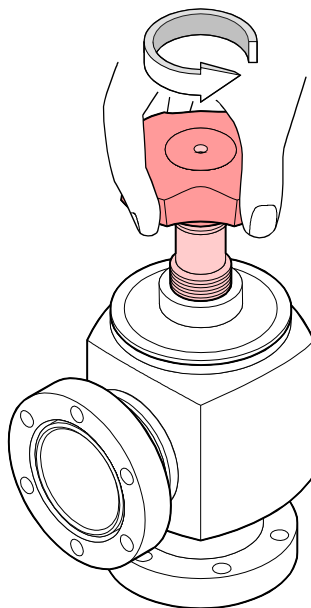

- 2 Place the valve on the rotary knob and carefully unscrew the valve plate by turning it clockwise with the supplied tool.

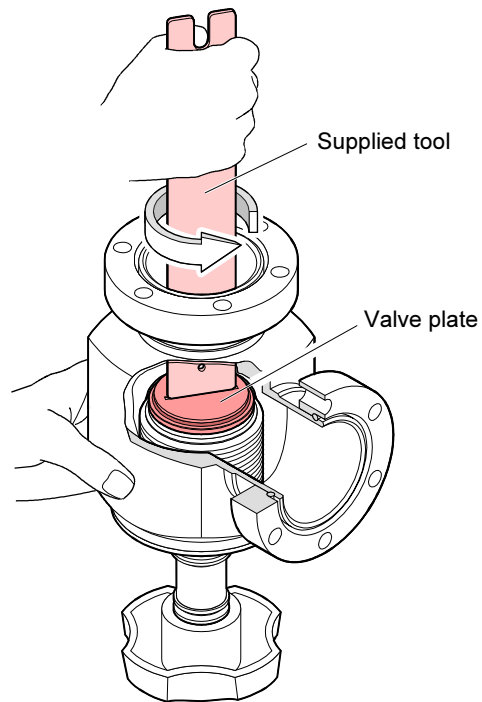

- Take out the valve plate with the supplied tool.

**Caution**

**Caution: mechanical stop**  
 The mechanical stop can easily get damaged by the tool or valve plate. If it is hurt, the angle valve is no longer tight and must be replaced.  
 Be careful not to damage the mechanical stop when deinstalling and reinstalling the valve plate.

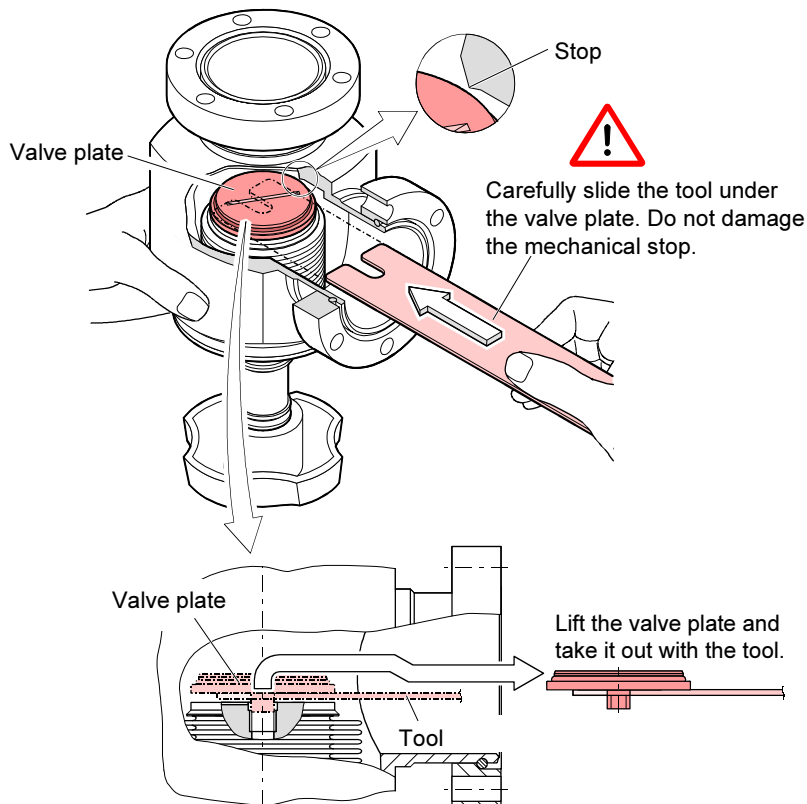

### 8.2.2 Replacing the O-Ring of the Valve Plate

- Remove the O-ring from the valve plate.

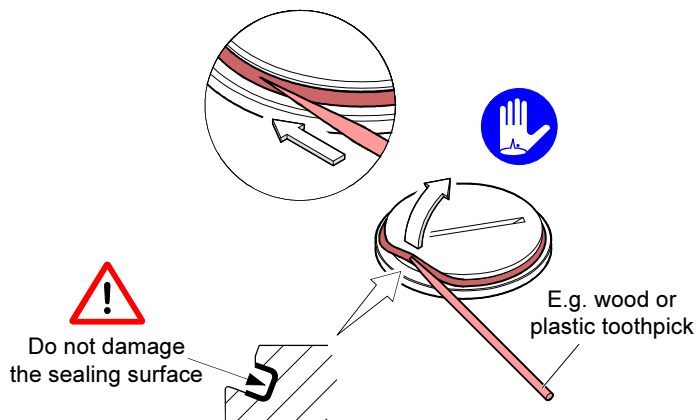

- 2 Insert a new O-ring.

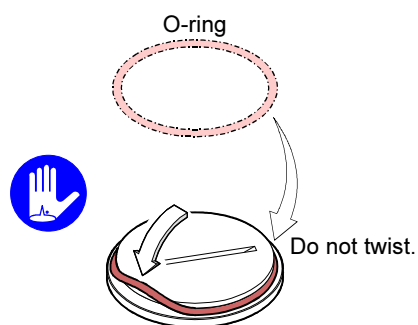

Be careful to insert the O-ring level into the sealing groove without twisting it.

Ordering number → 20.

### 8.2.3 Reinstalling the Valve Plate

- 1 Using the supplied tool, place the valve plate on the threaded tapped hole of the valve plate base.

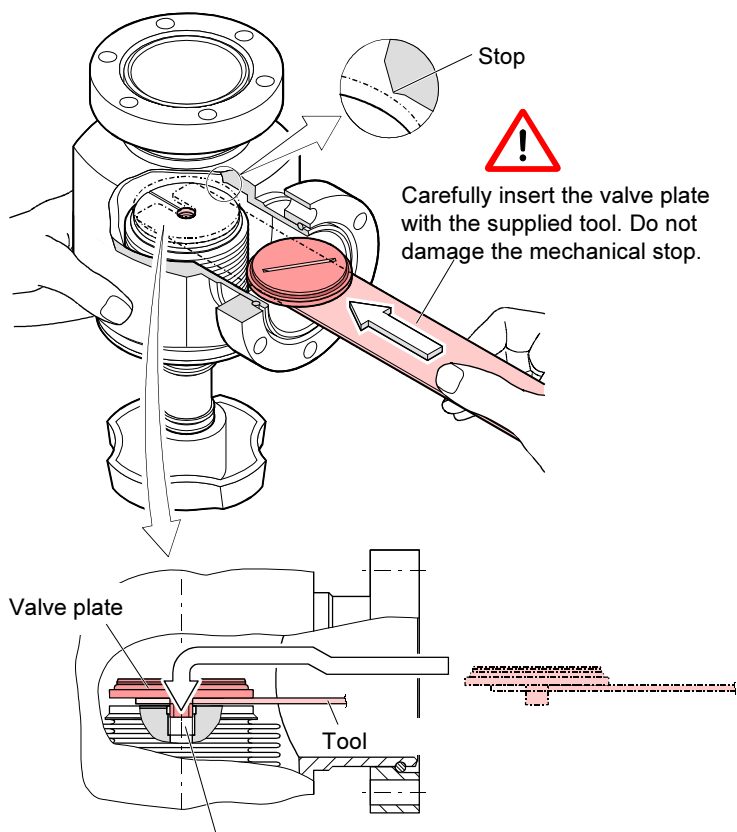

Place the valve plate on the threaded tapped hole of the valve plate base.

- ② Carefully screw the valve plate in by turning it clockwise with the supplied tool. Fasten it hand-tight.

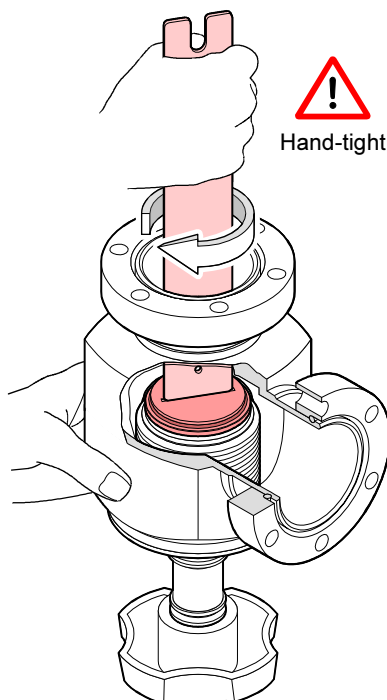

### 8.3 Cleaning the Angle Valve

**DANGER**

**Caution: cleaning agents**  
 Cleaning agents can be detrimental to health and environment. Adhere to the relevant regulations and take the necessary precautions when handling and disposing of cleaning agents. Consider possible reactions with the product materials (→ 6).

Clean the valve with alcohol, if possible in an ultrasonic bath. Let it dry thoroughly. Prior to putting the valve into operation, preferably bake it out (→ 10).

### 8.4 Actuator

The actuator has a permanent lubrication and therefore does not require any maintenance.

### 8.5 Leak Detection

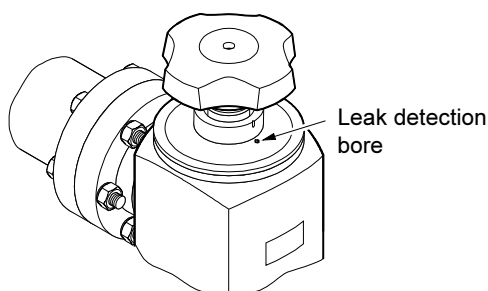

## 9 Repair

Defective angle valves cannot be repaired.

## 10 Spare Parts

When ordering spare parts, always indicate:

- all information on the product nameplate
- description and ordering number according to the spare parts list

O-rings

Flange	Seal	Pieces	Ordering number
DN 16 CF	O-ring, FPM75	10	215-341
DN 40 CF	O-ring, FPM75	10	215-342
DN 63 CF	O-ring, FPM75	10	215-343

Rotary knob

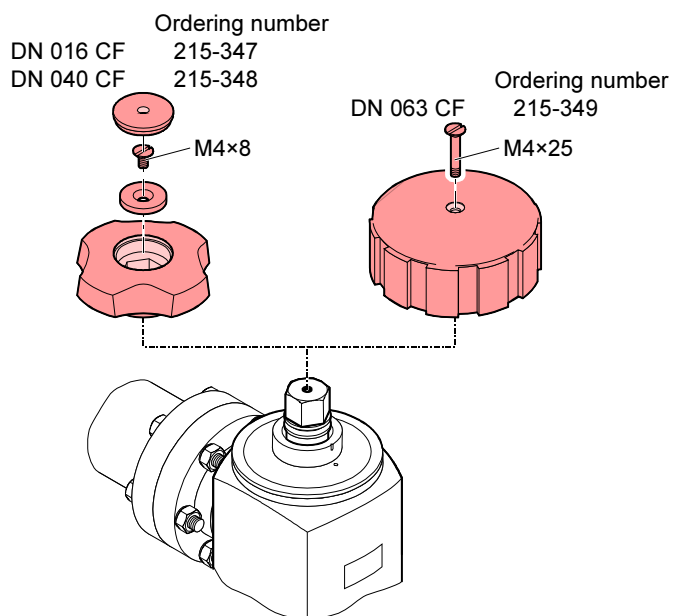

## 11 Accessories

Flange seals	Flange	Seal	Pieces	Ordering number
	DN 16 CF	Copper	10	213-371
	DN 40 CF	Copper	10	213-372
	DN 63 CF	Copper	10	213-373

Screw kits	Flange	Comprising	Pieces	Ordering number
	DN 16 CF	Hex head screw M4 × 20 mm, washer, hex nut	25	213-401
	DN 40 CF	Hex head screw M6 × 35 mm, washer, hex nut	25	213-402
	DN 63 CF	Hex head screw M8 × 50 mm, washer, hex nut	25	213-403

## 12 Storage



### Caution



Caution: vacuum component

Inappropriate storage leads to an increase of the desorption rate and/or may result in mechanical damage of the product.

- Cover the vacuum ports of the product with protective lids or grease free aluminum foil.
- Close the valve up to the stop position (which ensures optimum storage).

Do not exceed the admissible storage temperature range (→ 6).

## 13 Returning the Product



### WARNING

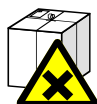

Caution: forwarding contaminated products

Contaminated products (e.g. radioactive, toxic, caustic or microbiological hazard) can be detrimental to health and environment.

Products returned to Inficon should preferably be free of harmful substances. Adhere to the forwarding regulations of all involved countries and forwarding companies and enclose a duly completed declaration of contamination (→ 23).

Products that are not clearly declared as "free of harmful substances" are decontaminated at the expense of the customer.

Products not accompanied by a duly completed declaration of contamination are returned to the sender at his own expense.

## 14 Disposal

**DANGER**

**Caution: contaminated parts**  
 Contaminated parts can be detrimental to health and environment.  
 Before beginning to work, find out whether any parts are contaminated.  
 Adhere to the relevant regulations and take the necessary precautions  
 when handling contaminated parts.

**WARNING**

**Caution: substances detrimental to the environment**  
 Products or parts thereof (mechanical and electric components,  
 operating fluids etc.) can be detrimental to the environment.  
 Dispose of such substances in accordance with the relevant local  
 regulations.

### Separating the components

After disassembling the product, separate its components according to the following criteria:

#### Contaminated components

Contaminated components (radioactive, toxic, caustic, or biological hazard etc.) must be decontaminated in accordance with the relevant national regulations, separated according to their materials, and disposed of.

#### Other components

Such components must be separated according to their materials and recycled.

# Declaration of Contamination

The service, repair, and/or disposal of vacuum equipment and components will only be carried out if a correctly completed declaration has been submitted. Non-completion will result in delay.  
 This declaration may only be completed (in block letters) and signed by authorized and qualified staff.

**1 Description of product**  
 Type \_\_\_\_\_  
 Article Number \_\_\_\_\_  
 Serial Number \_\_\_\_\_

**2 Reason for return**  
 \_\_\_\_\_  
 \_\_\_\_\_

**3 Operating fluid(s) used (Must be drained before shipping.)**  
 \_\_\_\_\_  
 \_\_\_\_\_

**4 Process related contamination of product:**

toxic	no <input type="checkbox"/> 1)	yes <input type="checkbox"/>	 2) Products thus contaminated will not be accepted without written evidence of decontamination!
caustic	no <input type="checkbox"/> 1)	yes <input type="checkbox"/>	
biological hazard	no <input type="checkbox"/>	yes <input type="checkbox"/> 2)	
explosive	no <input type="checkbox"/>	yes <input type="checkbox"/> 2)	
radioactive	no <input type="checkbox"/>	yes <input type="checkbox"/> 2)	
other harmful substances	no <input type="checkbox"/> 1)	yes <input type="checkbox"/>	

1) or not containing any amount of hazardous residues that exceed the permissible exposure limits

The product is free of any substances which are damaging to health  
 yes

**5 Harmful substances, gases and/or by-products**  
 Please list all substances, gases, and by-products which the product may have come into contact with:

Trade/product name	Chemical name (or symbol)	Precautions associated with substance	Action if human contact

**6 Legally binding declaration:**  
 I/we hereby declare that the information on this form is complete and accurate and that I/we will assume any further costs that may arise. The contaminated product will be dispatched in accordance with the applicable regulations.

Organization/company \_\_\_\_\_

Address \_\_\_\_\_ Post code, place \_\_\_\_\_

Phone \_\_\_\_\_ Fax \_\_\_\_\_

Email \_\_\_\_\_

Name \_\_\_\_\_

Date and legally binding signature \_\_\_\_\_ Company stamp \_\_\_\_\_

This form can be downloaded from our website.

Copies:  
 Original for addressee - 1 copy for accompanying documents - 1 copy for file of sender



sina02e1

Original: German sina02d1 (0010)



*LI-9496 Balzers  
Liechtenstein  
Tel +423 / 388 3116  
Fax +423 / 388 3701  
reach.liechtenstein@inficon.com*

*www.inficon.com*