

All-Metal Angle Valve

DN 16 ... 63 CF
manually operated
bellows sealed
metal valve seat seal

VAH016 ... 063-U

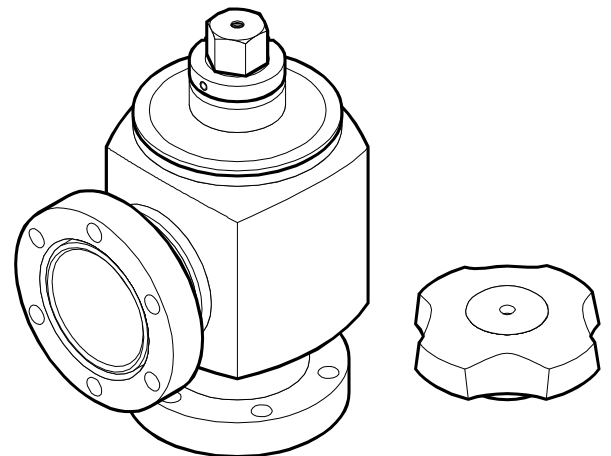

CE

Product Identification

In all communications with INFICON, please specify the information on the product nameplate. For convenient reference copy that information into the space provided below.

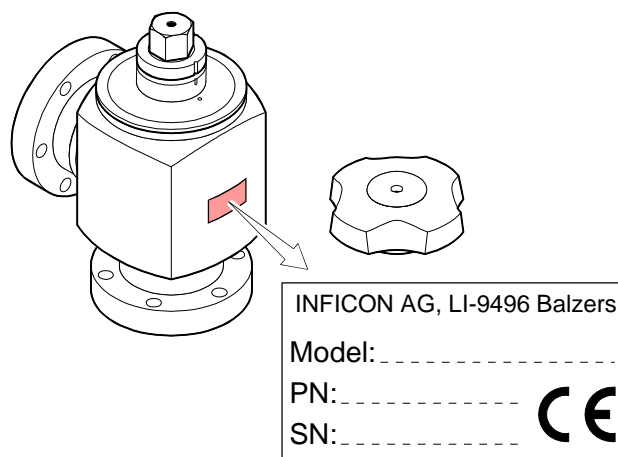

Validity

This document applies to products with part numbers

250-730 (VAH016-U DN 016 CF-R)

250-735 (VAH040-U DN 040 CF-R)

250-740 (VAH063-U DN 063 CF-R)

The part number (PN) can be taken from the product nameplate.

Illustrations

If not indicated otherwise in the legends, the illustrations in this document apply to valves with the nominal diameter DN 040. They apply to valves with other nominal diameters by analogy.

Technical changes

We reserve the right to make technical changes without prior notice.

Intended Use

The product is used as shut-off valve for HV and UHV applications. It can be baked out at 300 °C. The welded housing is suited for high-purity and toxic gases..

Contents

Product Identification	2
Validity	2
Intended Use	2
1 Description	4
1.1 Overview	4
1.2 Functional Principle	4
2 Safety	4
2.1 Symbols Used	4
2.2 Personnel Qualifications	5
2.3 General Safety Instructions	5
2.4 Liability and Warranty	5
3 Technical Data	6
4 Installation	8
4.1 Installation	8
4.1.1 Space Requirements	8
4.1.2 Flange Connection	9
5 Start-Up	10
5.1 Bakeout	10
5.2 Bringing the Valve Plate Into the Defined Position	11
6 Operation	12
6.1 Closing the Angle Valve	12
6.2 Opening the Angle Valve	15
7 Deinstallation	16
8 Maintenance	17
8.1 Bakeout	17
8.2 Replacing the Valve Plate	17
8.2.1 Deinstalling the Valve Plate	17
8.2.2 Installing a New Valve Plate	19
8.3 Adjusting the Sealing Elements	20
8.4 Adjustment Ring Setting	21
8.5 Cleaning the Angle Valve	23
8.6 Actuator	23
8.7 Leak Detection	23
9 Repair	24
10 Spare Parts	24
11 Accessories	25
12 Storage	25
13 Returning the Product	25
14 Disposal	26
Declaration of Contamination	27

1 Description

1.1 Overview

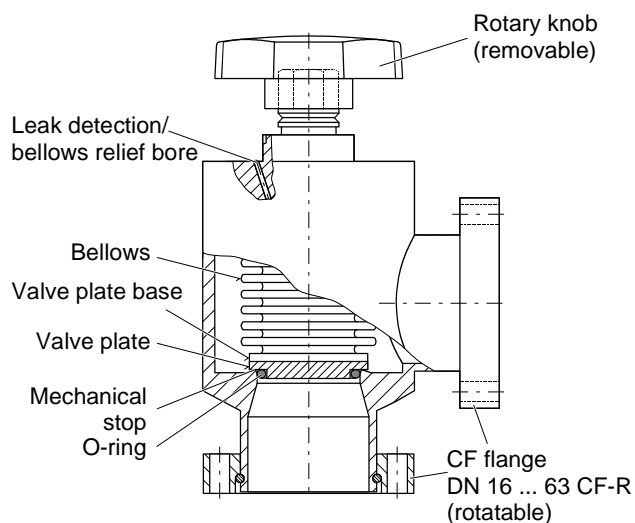

1.2 Functional Principle

The sealing effect of the Angle valve is achieved by pressing the valve plate against the sealing edge. The valve housing is welded.

2 Safety

2.1 Symbols Used



Information on preventing any kind of physical injury.



Information on preventing extensive equipment and environmental damage.



Information on correct handling or use. Disregard can lead to malfunctions or minor equipment damage.

→ See page ...

2.2 Personnel Qualifications



Skilled personnel

All work described in this document may only be carried out by persons who have suitable technical training and the necessary experience or who have been instructed by the end-user of the product.

2.3 General Safety Instructions

- Adhere to the applicable regulations and take the necessary precautions for the process media used.
Consider possible reactions between the materials (→ 6) and the process media.
- Adhere to the applicable regulations and take the necessary precautions for all work you are going to do and consider the safety instructions in this document.
- Before beginning to work, find out whether any vacuum components are contaminated. Adhere to the relevant regulations and take the necessary precautions when handling contaminated parts.

Communicate the safety instructions to all other users.

2.4 Liability and Warranty

INFICON assumes no liability and the warranty becomes null and void if the end-user or third parties

- disregard the information in this document
- use the product in a non-conforming manner
- make any kind of interventions (modifications, alterations etc.) on the product
- use the product with accessories not listed in the corresponding product documentation.

The end-user assumes the responsibility in conjunction with the process media used.

3 Technical Data

Connection flanges, rotatable VAH016-U VAH040-U VAH063-U	DN 16 CF-R DN 40 CF-R DN 63 CF-R
Installation angle	any
Flow direction	any
Tightness	1×10^{-12} mbar/s
Pressure range	1×10^{-11} mbar ... 4 bar (absolute)
Bursting pressure	8 bar
Conductance VAH016-U VAH040-U VAH063-U	3 l/s 38 l/s 100 l/s
Temperatures ambience operation bakeout (without rotary knob, closed, pressure in vacuum system $< 1 \times 10^{-4}$ mbar or vacuum system vented with inert gas) rotary knob continuous temporary storage	0 °C ... 55 °C ≤ 300 °C ≤ 300 °C ≤ 80 °C 80 ... 110 °C +5 ... +45 °C -15 ... +45 °C ¹⁾
Temperature increase VAH016-U VAH040-U VAH063-U	≤ 4 °C/minute ≤ 4 °C/minute ≤ 2 °C/minute
Closing torque VAH016-U VAH040-U VAH063-U	2 ... 10 Nm 8 ... 30 Nm 30 ... 60 Nm
Service life of sealing plate (cold closing operations)	1000 cycles
Lift (opening) VAH016-U VAH040-U VAH063-U	12 mm 23 mm 33 mm
Materials housing spindle VAH016-U VAH040-U, VAH063-U spindle flange bellows valve plate base valve plate forming ring sealing plate rotary knob	stainless steel 1.4301 stainless steel 1.4301 ²⁾ CuSn8 2.1030.26 ³⁾ stainless steel 1.4301 stainless steel 1.4541 stainless steel 1.4301 ESU stainless steel 1.4301 copper PA 15% GF
Weight VAH016-U VAH040-U VAH063-U	0.4 kg 2.0 kg 5.0 kg

¹⁾ Ambience free of condensable gases.

²⁾ Older type: CuSn8 2.1030.26 ³⁾

³⁾ Permanent lubrication, requires no maintenance.

Dimensions [mm]

VAH016-U

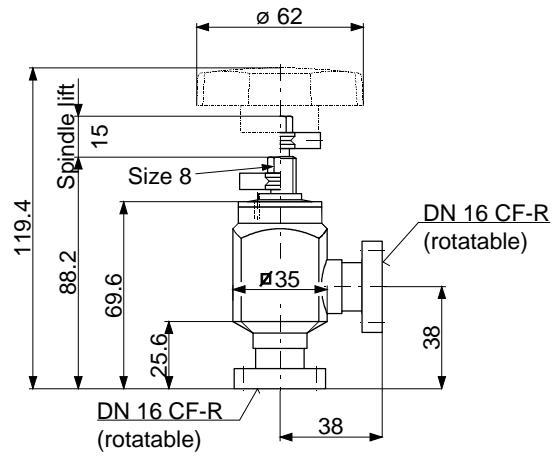

VAH040-U

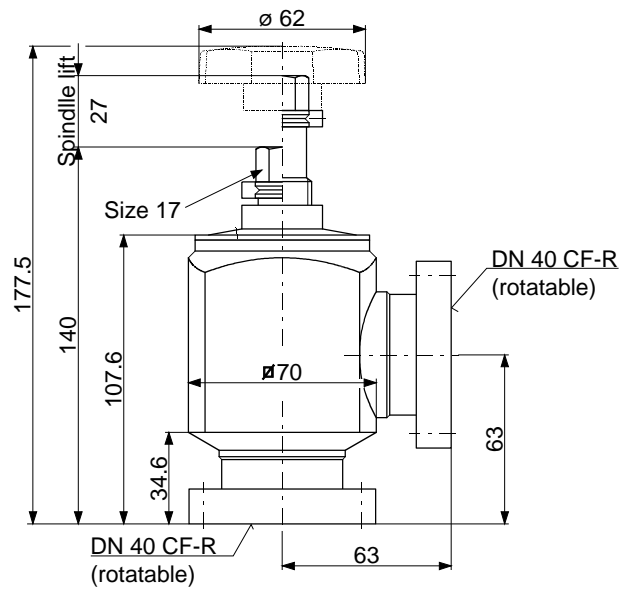

VAH063-U

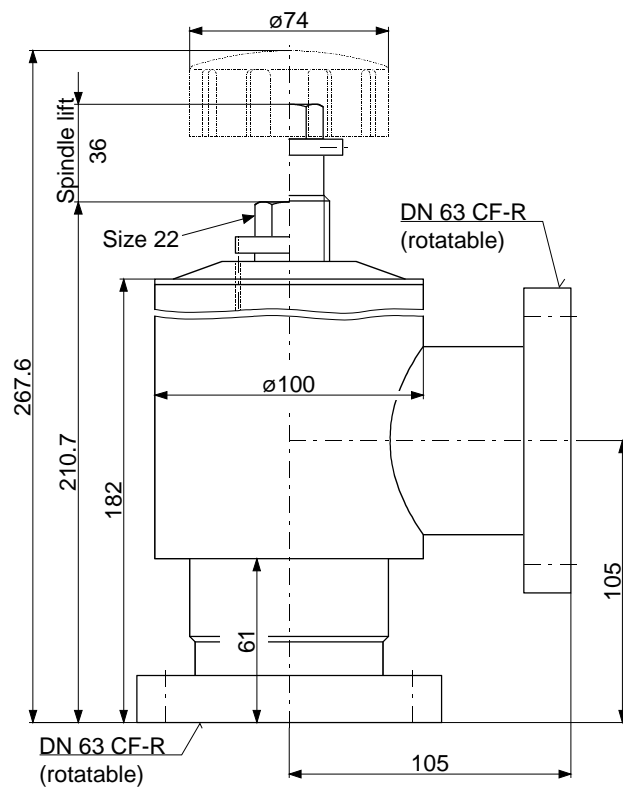

4 Installation



Caution



Caution: vacuum component
Dirt and damages impair the function of the vacuum component.
When handling vacuum components, take appropriate measures to ensure cleanliness and prevent damages.



Caution



Caution: dirt sensitive area
Touching the product or parts thereof with one's bare hands increases the desorption rate.
Always wear clean, lint-free gloves and use clean tools when working in this area.



Caution



Caution: factory adjustment
The valve is delivered

- with the adjustment ring set to the closing torque
- with the valve plate lying on the sealing edge without being pressed against it (which ensures optimum storage).

Bear in mind that the valve is not tight in this condition. Do not loosen the adjustment ring nor perform any opening or closing operation until the valve is put into operation.

The protective packaging should not be removed until shortly before installation. Even the slightest contamination could cause leaks.

4.1 Installation

4.1.1 Space Requirements

Make sure the valve can be operated without any risk of bodily injury.

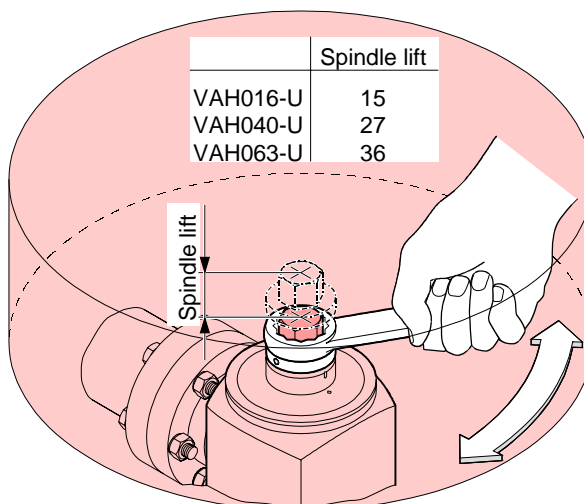

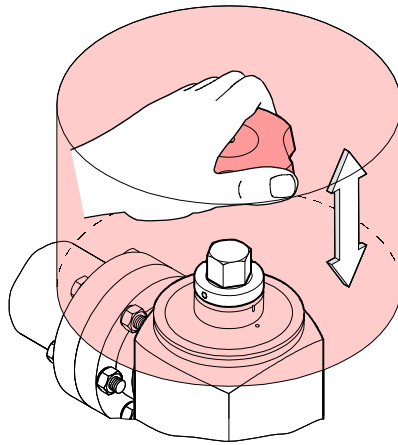

4.1.2 Flange Connection

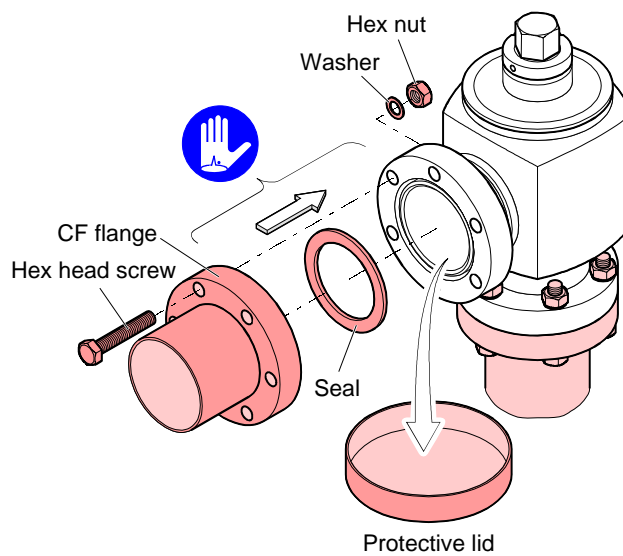

Keep the protective lids.

Flange seals

Flange	Seal	Pieces	Ordering number
DN 16 CF	Copper	10	213-371
	Copper, silver-plated	10	213-381
DN 40 CF	Copper	10	213-372
	Copper, silver-plated	10	213-382
DN 63 CF	Copper	10	213-373
	Copper, silver-plated	10	213-383

Screws (Accessories → 25)/ Torque

Flange	Hex head screw	Pieces	Required torque
DN 16 CF	M4 × 20 mm	6 per flange	4 Nm
DN 40 CF	M6 × 35 mm	6 per flange	10 Nm
DN 63 CF	M8 × 50 mm	8 per flange	20 Nm

5 Start-Up

5.1 Bakeout

It is good practice to bake out new valves and valves the inner parts of which have been exposed to atmosphere for some time, e.g. with a heating jacket.

DANGER

Caution: hot surface
Touching the hot surface (>55 °C) can cause burns.
Do not touch the hot surface.

Caution

Caution: bakeout at atmosphere
Bakeout with the inner parts of the valve exposed to atmosphere may lead to the formation of oxides and thus cause leaks.
Bake out the valve only if

- the pressure in the vacuum system is $<1 \times 10^{-4}$ mbar or
- the vacuum system has been vented with inert gas.

Caution

Caution: bakeout temperature >100 °C
The rotary knob may be continually exposed to temperatures <100 °C only.
Remove the rotary knob before baking out the valve.

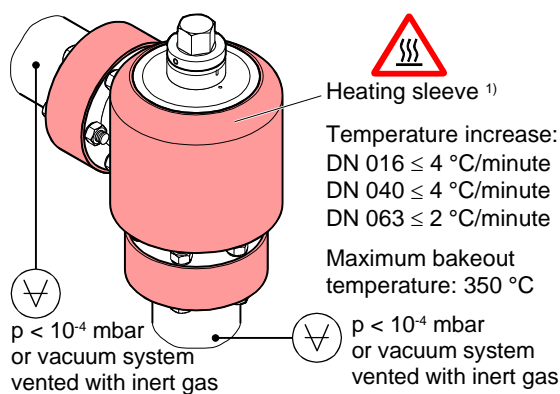

¹⁾ Not enclosed in the delivery.

5.2 Bringing the Valve Plate Into the Defined Position

Using a ring wrench, turn the hex head until mark ① on the adjustment ring is in line with the mark on the valve housing.

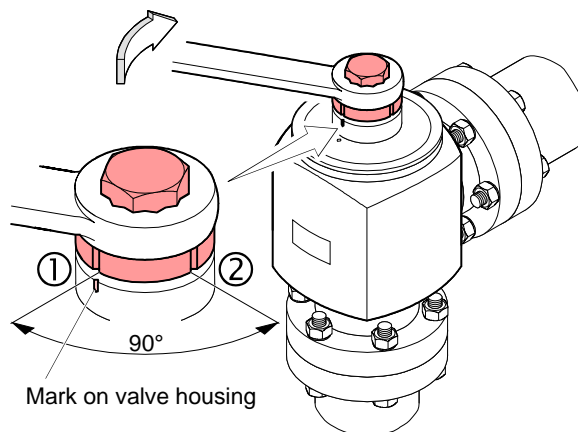

The valve is closed and ready for use now.

6 Operation

Prevent the entry of dirt, dust, or other abrasive contamination into the valve. Even very small particles on the sealing surfaces may cause leaks.

DANGER



Caution: hot surface
Touching the hot surface (>55 °C) can cause burns.
Wear protective gloves.

Caution



Caution: bakeout at atmosphere
Bakeout with the inner parts of the valve exposed to atmosphere may lead to the formation of oxides and thus cause leaks.
Bake out the valve only if

- the pressure in the vacuum system is $<1 \times 10^{-4}$ mbar or
- the vacuum system has been vented with inert gas.

Caution



Caution: position of the adjustment ring
Closing the valve with an incorrectly set adjustment ring may cause damages.
Close the valve with the minimum torque using a torque wrench. Check that the valve is tight. If it is not yet tight, gradually increase the closing torque in small steps ($\Delta\alpha \approx 5^\circ$) until the valve is tight. Do not exceed the maximum closing torque.

	Closing torque	
	minimum	maximum
VAH016-U	2 Nm	10 Nm
VAH040-U	8 Nm	30 Nm
VAH063-U	30 Nm	60 Nm

6.1 Closing the Angle Valve

Operating temperature >55 °C

- 1 Using a ring wrench, position the valve plate on the sealing edge by turning the hex head clockwise until an increased resistance can be felt.

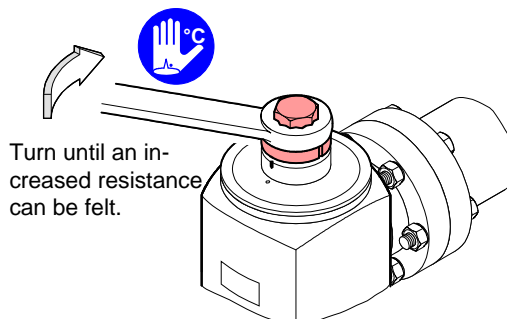

Operating temperature $\leq 55\text{ }^{\circ}\text{C}$

Position the valve plate on the sealing edge by turning the rotary knob clockwise until an increased resistance can be felt. Remove the rotary knob.

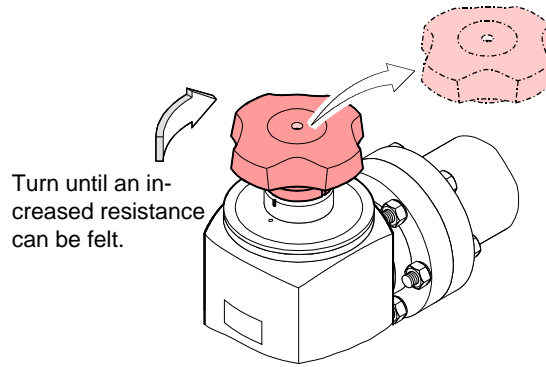

- 2 Close the valve by turning the hex head clockwise with a ring wrench until mark ① on the adjustment ring is in line with the mark on the valve housing. Remove the ring wrench.

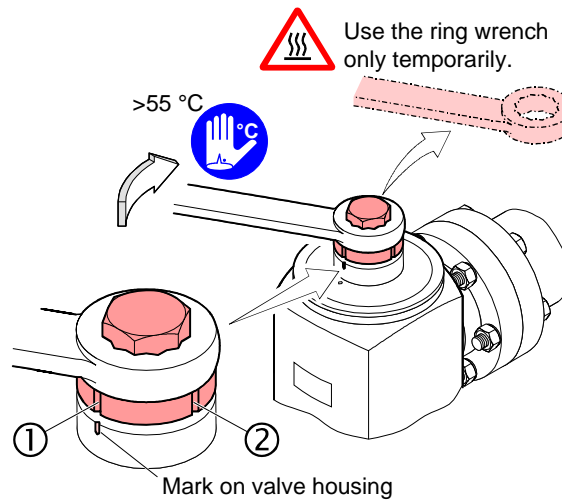

- 3 Check that the valve is tight. If it is not yet tight, keep gradually turning the hex head in small steps ($\Delta\alpha \approx 5^\circ$) until the valve is tight. However, do not turn the hex head any further when mark ② ($\alpha = 90^\circ$) on the adjustment ring is in line with the mark on the valve housing.



Caution



Caution: maximum closing torque

The maximum closing torque (mark ② on the adjustment ring is in line with the mark on the valve housing) must not be exceeded. If the maximum torque is exceeded, the sealing surfaces of the valve and/or the spindle may get damaged.

When the maximum closing torque has been reached, it is recommended to exchange the valve plate before running any further processes (→ 17).

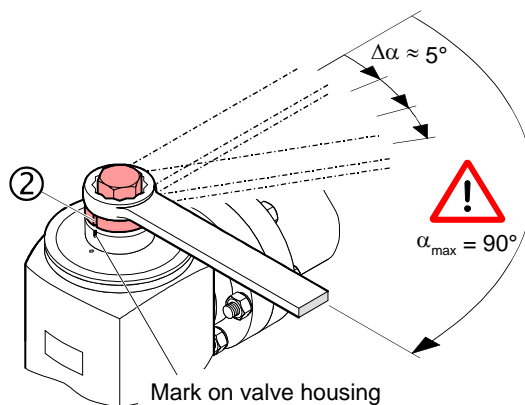

A leak test must be performed if in a process

- the temperature was significantly increased by the heater and/or due to the process itself
- the bakeout time was significantly increased.

6.2 Opening the Angle Valve

The maximum opening of the valve is limited by a mechanical stop.

- 1 Open the valve by turning the hex head counter-clockwise with a ring wrench until the resistance decreases. Remove the ring wrench.

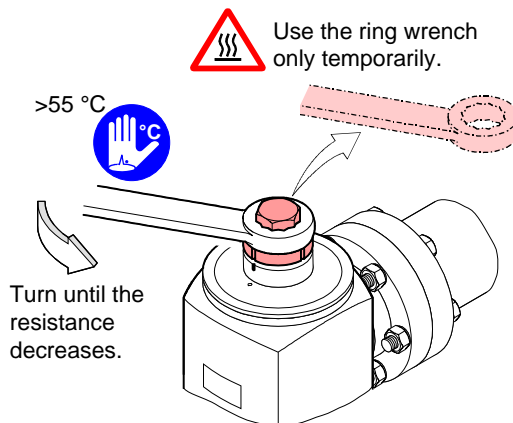

Operating temperature >55 °C

- 2 Continue opening the valve by turning the hex head counter-clockwise with the ring wrench. Remove the ring wrench.

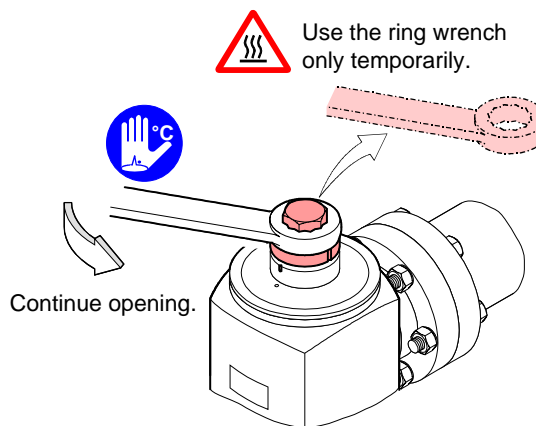

Operating temperature ≤55 °C

- Continue opening the valve by turning the rotary knob counter-clockwise. Remove the rotary knob.

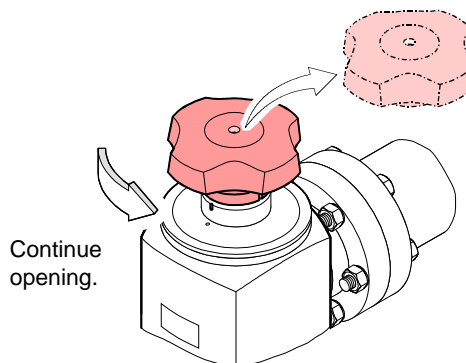

7 Deinstallation

DANGER



Caution: contaminated parts
Contaminated parts can be detrimental to health and environment. Before beginning to work, find out whether any parts are contaminated. Adhere to the relevant regulations and take the necessary precautions when handling contaminated parts.

Caution



Caution: vacuum component
Dirt and damages impair the function of the vacuum component. When handling vacuum components, take appropriate measures to ensure cleanliness and prevent damages.



Vent the vacuum system and wait until the valve has cooled down to <math>< 50\text{ }^\circ\text{C}</math>.

Detach the flanges and put the protective lids in place.

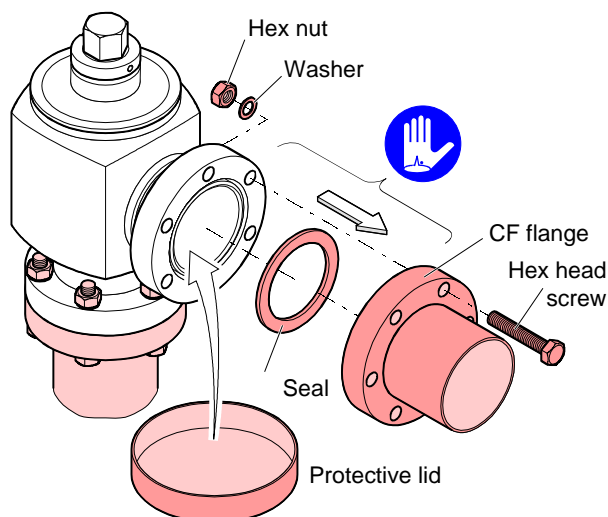

When the valve is reinstalled, replacing the seals is recommended (→ 9).

8 Maintenance

8.1 Bakeout

The valve is baked in order for its inner parts to be degassed. Undesirable gases can thus be pumped. The pumping time is reduced and the final pressure is reached faster.

It is good practice to bake out valves after cleaning (→ 23) and when their inner parts have been exposed to atmosphere for some time, e.g. with a heating jacket (→ 10).

8.2 Replacing the Valve Plate

 **DANGER**



Caution: contaminated parts

Contaminated parts can be detrimental to health and environment.

Before beginning to work, find out whether any parts are contaminated. Adhere to the relevant regulations and take the necessary precautions when handling contaminated parts.

 **Caution**



Caution: dirt sensitive area

Touching the product or parts thereof with one's bare hands increases the desorption rate.

Always wear clean, lint-free gloves and use clean tools when working in this area.

The valve plate can only be replaced if the valve has been deinstalled (→ 16).

8.2.1 Deinstalling the Valve Plate

- 1** Open the valve until the stop position is reached.

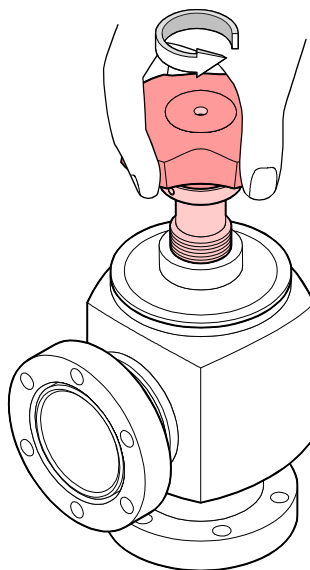

- 2** Place the valve on the rotary knob and carefully unscrew the valve plate by turning it clockwise with the supplied tool.

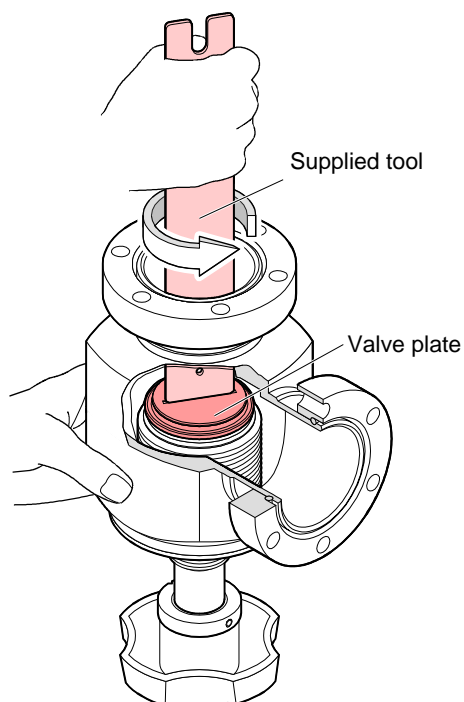

- 3** Take out the valve plate with the supplied tool.



Caution



Caution: sealing edge

The sealing edge can easily get damaged by a tool or the valve plate. If it is hurt, the angle valve is no longer tight and must be replaced.

Be careful not to damage the sealing edge when deinstalling and reinstalling the valve plate.

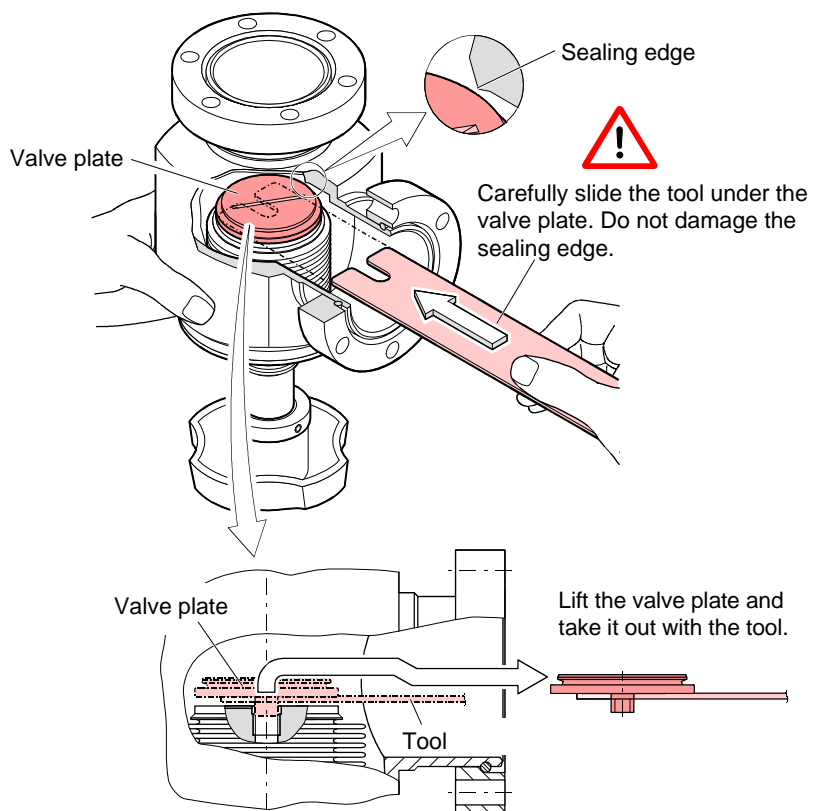

8.2.2 Installing a New Valve Plate

- Using the supplied tool, place the valve plate on the threaded tapped hole of the valve plate base.

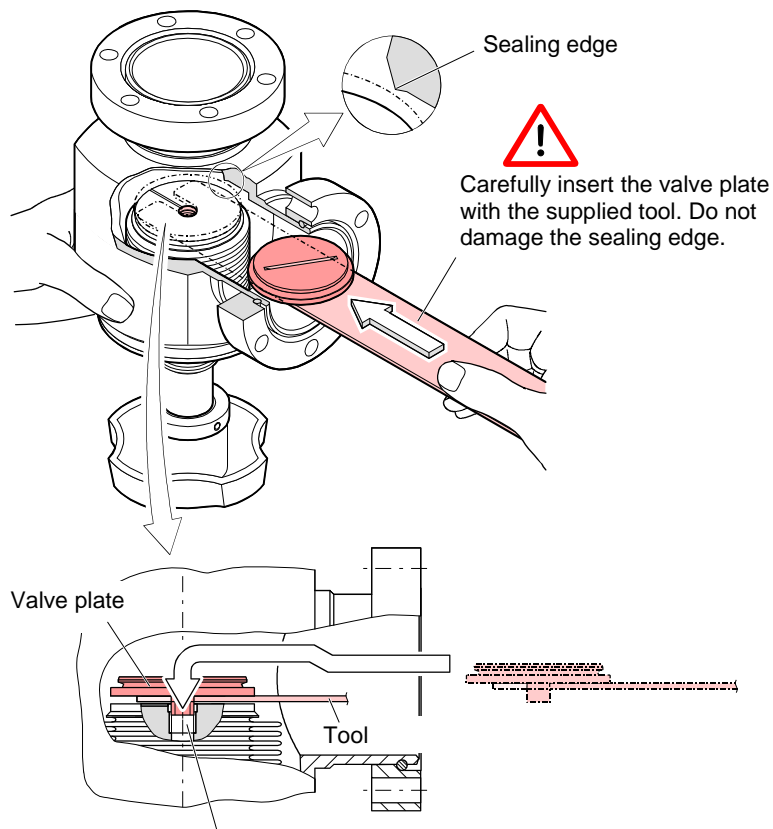

Place the valve plate on the threaded tapped hole of the valve plate base.

Ordering number → 24.

- 2 Carefully screw the valve plate in by turning it clockwise with the supplied tool. Fasten it hand-tight.

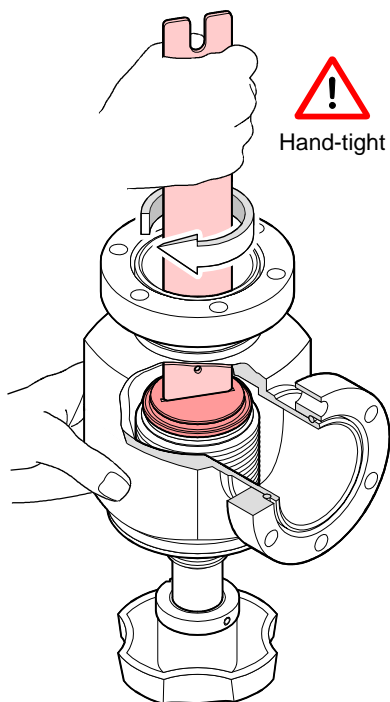

8.3 Adjusting the Sealing Elements

After the valve plate has been replaced, the sealing elements (valve plate and sealing edge) must be adjusted.

- 1 Position the valve plate on the sealing edge by carefully turning the rotary knob clockwise until an increased resistance can be felt. Remove the rotary knob.

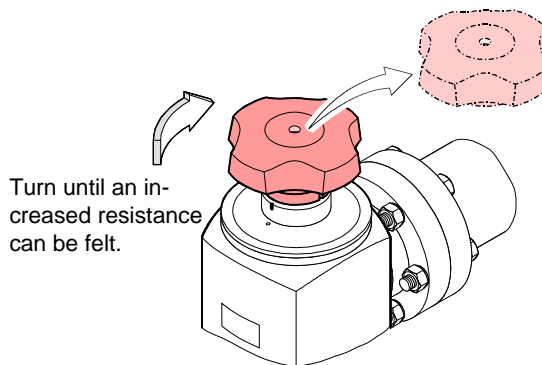

- 2** Close the valve by turning the ring wrench clockwise for an angle of α_a .

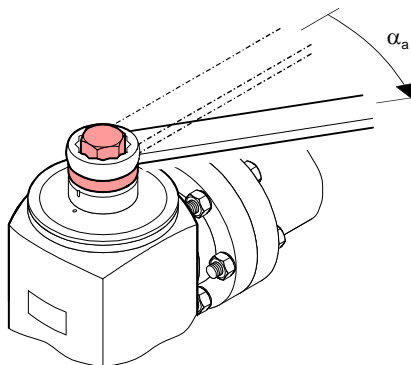

Angle valve	α_a
VAH016-U	15°
VAH040-U	20°
VAH063-U	30° ¹⁾

¹⁾ Preliminary information.

- 3** Open the valve by turning the ring wrench counter-clockwise until the resistance decreases.

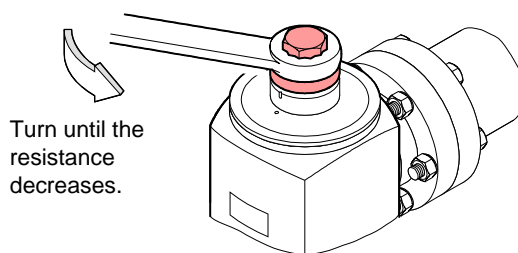

8.4 Adjustment Ring Setting

After installation of a new valve plate, the adjustment ring setting must be corrected.

- 1** Using the torque wrench, close the valve with the minimum closing torque.

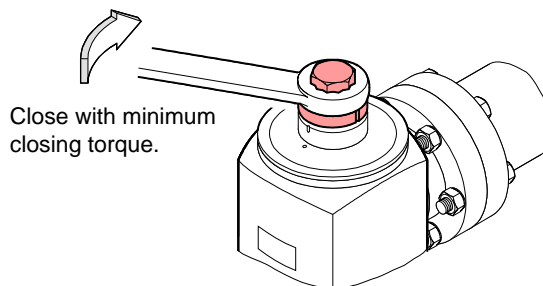

Angle valve	Minimum closing torque
VAH016-U	2 Nm
VAH040-U	8 Nm
VAH063-U	30 Nm

- 2** Check tightness. If the valve is not tight, turn the ring wrench clockwise in small steps ($\Delta\alpha \approx 5^\circ$), until the valve is tight.

Caution

Caution: $\alpha > 30^\circ$
 At $\alpha > 30^\circ$, the 90° mark ② on the adjustment ring can no longer be used (→ 14).
 Close the valve with a torque wrench
 or
 replace the valve plate.

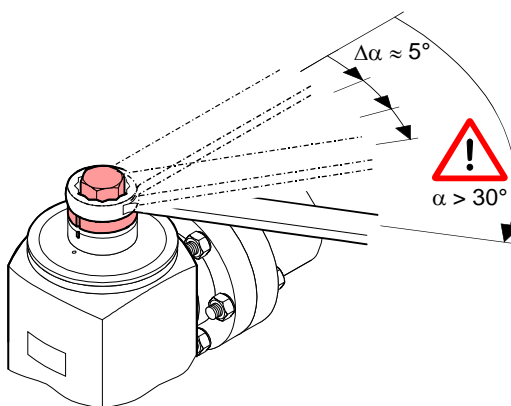

- 3** Loosen the hex socket screw of the adjustment ring with an Allen wrench (size 1.5 mm).

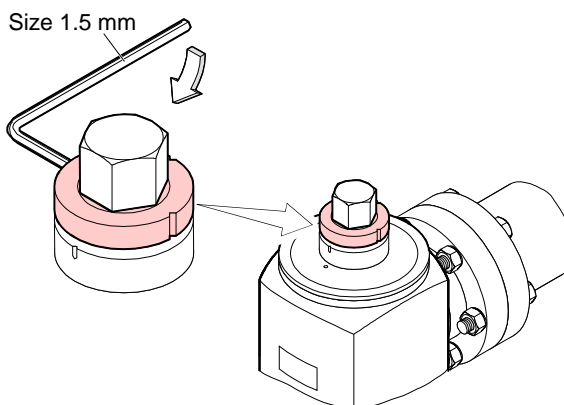

- 4** Turn the adjustment ring until mark ① on the adjustment ring is in line with the mark on the valve housing.

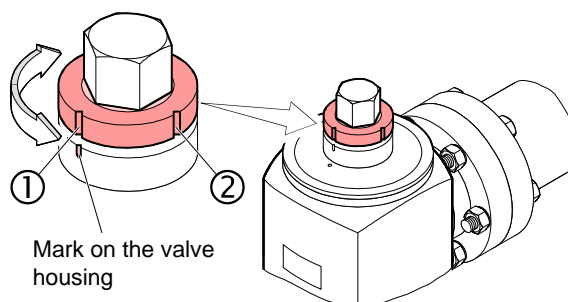

- 5** Lock the adjustment ring in this position by fastening the hex socket screw with the Allen wrench.

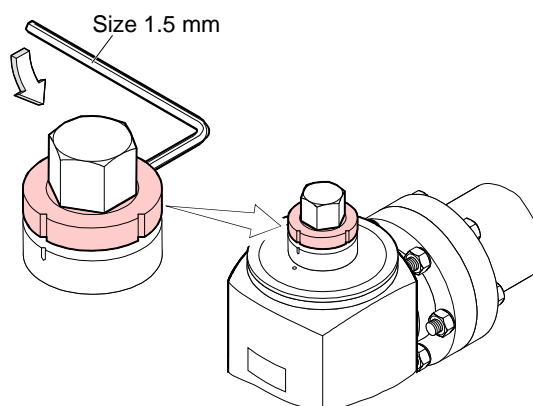

8.5 Cleaning the Angle Valve

DANGER

Caution: cleaning agents
 Cleaning agents can be detrimental to health and environment. Adhere to the relevant regulations and take the necessary precautions when handling and disposing of cleaning agents. Consider possible reactions with the product materials (→ 6).

Clean the valve with alcohol, if possible in an ultrasonic bath. Let it dry thoroughly. Prior to putting the valve into operation, preferably bake it out (→ 10).

8.6 Actuator

The actuator has a permanent lubrication and therefore does not require any maintenance.

8.7 Leak Detection

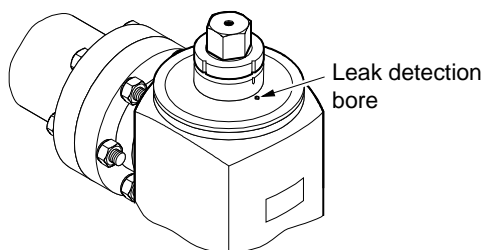

9 Repair

Defective angle valves cannot be repaired.

10 Spare Parts

When ordering spare parts, always indicate:

- all information on the product nameplate
- description and ordering number according to the spare parts list

Valve plate

Flange	Sealing plate	Pieces	Ordering number
DN 16 CF	Copper	2	215-344
DN 40 CF	Copper	2	215-345
DN 63 CF	Copper	2	215-346

Rotary knob

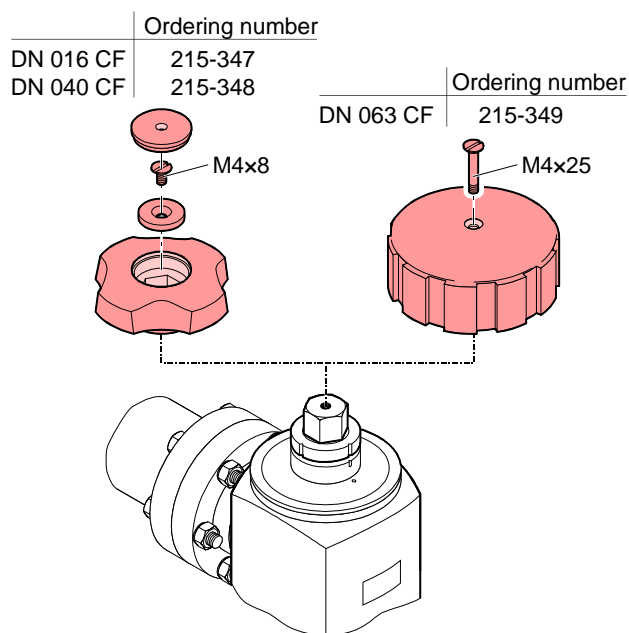

11 Accessories

Flange seals	Flange	Seal	Pieces	Ordering number
	DN 16 CF	Copper	10	213-371
		Copper, silver-plated	10	213-381
	DN 40 CF	Copper	10	213-372
		Copper, silver-plated	10	213-382
	DN 63 CF	Copper	10	213-373
		Copper, silver-plated	10	213-383

Screw kits	Flange	Comprising	Pieces	Ordering number
	DN 16 CF	Hex head screw M4 x 20 mm, washer, hex nut	25	213-401
	DN 40 CF	Hex head screw M6 x 35 mm, washer, hex nut	25	213-402
	DN 63 CF	Hex head screw M8 x 50 mm, washer, hex nut	25	213-403

12 Storage



Caution



Caution: vacuum component

Inappropriate storage leads to an increase of the desorption rate and/or may result in mechanical damage of the product.

- Cover the vacuum ports of the product with protective lids or grease free aluminum foil.
- Close the valve with the rotary knob until an increased resistance can be felt. The valve plate lies now on the sealing edge without being pressed against it (which ensures optimum storage).

Do not exceed the admissible storage temperature range (→ 6).

13 Returning the Product



WARNING



Caution: forwarding contaminated products

Contaminated products (e.g. radioactive, toxic, caustic or microbiological hazard) can be detrimental to health and environment.

Products returned to INFICON should preferably be free of harmful substances. Adhere to the forwarding regulations of all involved countries and forwarding companies and enclose a duly completed declaration of contamination (→ 27).

Products that are not clearly declared as "free of harmful substances" are decontaminated at the expense of the customer.

Products not accompanied by a duly completed declaration of contamination are returned to the sender at his own expense.

14 Disposal

DANGER

Caution: contaminated parts

Contaminated parts can be detrimental to health and environment. Before beginning to work, find out whether any parts are contaminated. Adhere to the relevant regulations and take the necessary precautions when handling contaminated parts.

WARNING

Caution: substances detrimental to the environment

Products or parts thereof (mechanical and electric components, operating fluids etc.) can be detrimental to the environment. Dispose of such substances in accordance with the relevant local regulations.

Separating the components

After disassembling the product, separate its components according to the following criteria:

Contaminated components

Contaminated components (radioactive, toxic, caustic, or biological hazard etc.) must be decontaminated in accordance with the relevant national regulations, separated according to their materials, and disposed of.

Other components

Such components must be separated according to their materials and recycled.

Original: German sina01d1-a (2005-09)



sina01e1-a



*LI-9496 Balzers
Liechtenstein
Tel +423 / 388 3111
Fax +423 / 388 3700
reachus@inficon.com*

www.inficon.com