

Angle Valve

pneumatically actuated
bellows sealed
with non-contact position indicator
with pilot valve

VAP160-A Reed

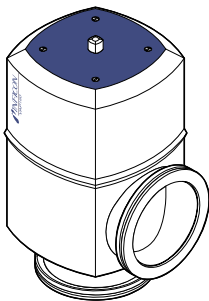

Short Operating Instructions
Incl. Declaration of Incorporation

Product Identification

In all communications with INFICON please specify the information on the product nameplate. For convenient reference copy that information into the space provided below:

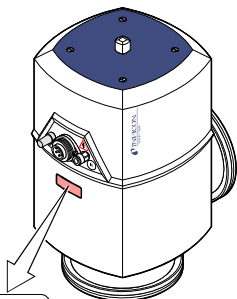

INFICON AG, LI-9496 Balzers	
Model:	
PN:	
SN:	
..... V W

Validity

This document applies to products with part number
250-448

The part number (PN) can be taken from the product nameplate.

We reserve the right to make technical changes without prior notice.

All dimensions in mm.

Intended Use

The Angle Valve is used as shut-off and venting device for vacuum applications.

Description

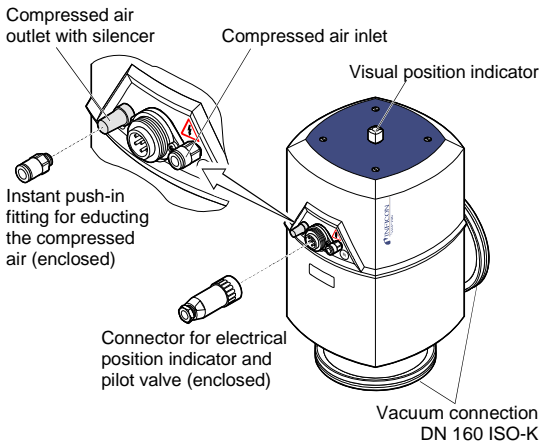



Functional Principle

When the pilot valve is activated, the pneumatic actuator opens the angle valve. The visual position indicator becomes visible, and the electrical position indicator "valve open" is activated.

When the pilot valve is de-energized, the pneumatic actuator is vented, and the angle valve is closed by the pressure spring. The visual position indicator is no longer visible, and the electrical position indicator "valve closed" is activated.

Contents

Product Identification	2
Validity	2
Intended Use	3
Description	3
1 Safety	5
1.1 Symbols Used	5
1.2 Personnel Qualifications	5
1.3 General Safety Instructions	6
1.4 Liability and Warranty	6
2 Technical Data	7
3 Installation	10
3.1 Vacuum Connection	10
3.2 Compressed Air Connection	12
3.3 Electrical Connection	16
4 Operation	19
5 Deinstallation	20
5.1 Electrical Connection	20
5.2 Compressed Air Connection	22
5.3 Vacuum Connection	24
6 Maintenance / Repair	26
7 Returning the Product	26
8 Disposal	27
Declaration of Contamination	28
Declaration of Incorporation	29

For cross-references within this document, the symbol (→  XY) is used, for cross-references to further documents the symbol (→  [Z]).

1 Safety

1.1 Symbols Used



DANGER

Information on preventing any kind of physical injury.



WARNING

Information on preventing extensive equipment and environmental damage.



Caution

Information on correct handling or use. Disregard can lead to malfunctions or minor equipment damage.

1.2 Personnel Qualifications



Skilled personnel

All work described in this document may only be carried out by persons who have suitable technical training and the necessary experience or who have been instructed by the end-user of the product.

1.3 General Safety Instructions

- Adhere to the applicable regulations and take the necessary precautions for the process media used.
Consider possible reactions between the materials and the process media.
- Adhere to the applicable regulations and take the necessary precautions for all work you are going to do and consider the safety instructions in this document.
- Before beginning to work, find out whether any vacuum components are contaminated. Adhere to the relevant regulations and take the necessary precautions when handling contaminated parts.

Communicate the safety instructions to all other users.

1.4 Liability and Warranty

INFICON assumes no liability and the warranty becomes null and void if the end-user or third parties

- disregard the information in this document
- use the product in a non-conforming manner
- make any kind of interventions (modifications, alterations etc.) on the product
- use the product with accessories not listed in the corresponding product documentation.

The end-user assumes the responsibility in conjunction with the process media used.

Failures due to contamination or wear and tear, as well as expendable parts (e.g. seals), are not covered by the warranty.

2 Technical Data

Pilot valve	
Type of connection	soldered joints
Nominal voltage	24 VDC
Pickup / holding power	1.6 / 1.6 W
Duty cycle	100%
Nominal diameter	4
Position indicator	
Rating	50 VDC / 10 W / 0.2 A
Vacuum connection	DN 160 ISO-K
Actuation	opening: pneumatic closing: by pressure spring
Compressed air supply	
Tube connection	ø6 mm
Pressure range	4 ... 8 bar overpressure
Purity classes	2 4 1 (ISO 8573-1)
Piston displacement	570 cm ³
Stroke of the valve plate	35 mm
Conductance ¹⁾	800 l/s
Switching frequency ²⁾	40 / min
Opening time ²⁾	600 ms
Closing time ²⁾	650 ms
Cycle life ³⁾	1.5 million
Tightness	1×10 ⁻⁹ mbar l/s (He)
Pressure range	1×10 ⁻⁸ mbar ... 1.5 bar (absolute)
Resistance to pressure	4 bar (absolute)

¹⁾ For air with molecular flow.

²⁾ In a vacuum, pressure difference $\Delta p = 0$, and compressed air = 6 bar (overpressure).

³⁾ Cycles without expendable parts (seals) and under clean operating conditions.
If the valve is operated under harsh or dirty conditions, it should be cleaned / maintained before the specified service time to maintenance has been reached.

Pressure difference Δp In closing direction	1.5 bar
In opening direction	1.5 bar
Opens to a pressure difference Δp ⁴⁾	1.5 bar
Temperatures	
Ambiance	5 ... 60 °C
Bakeout	
Housing	80 °C
Actuator	60 °C
Pilot valve	60 °C
Type of protection	IP 54
Installation angle	any
Flow direction ⁵⁾	any
Materials	
Housing	DIN 3.2373.62
Bellows / valve plate	DIN 1.4541 / DIN 1.4301
Pressure spring	DIN 1.1200
Seals	FPM
Cover	styrol-butadiene
Cylinder unit	DIN 3.2371.61
Protective lids	PE
Packing material	carton box, PE, PU
Weight	11.4 kg

⁴⁾ Compressed air = 4 bar (overpressure).

⁵⁾ Recommended mounting orientation: valve seat toward vacuum chamber.

Dimensions [mm]

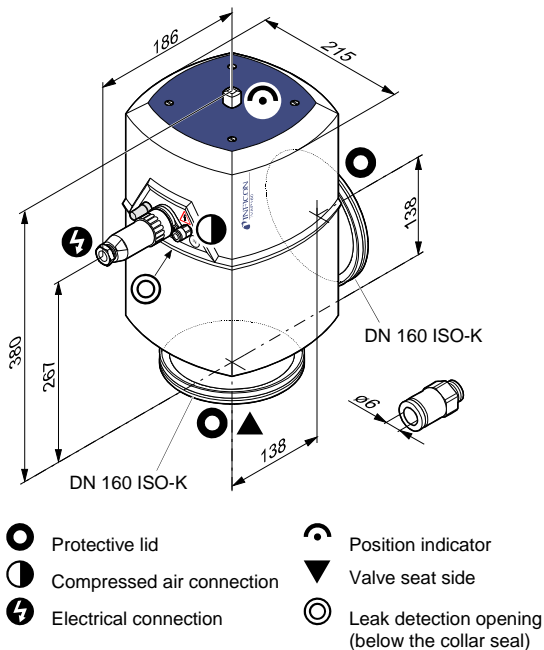

3 Installation

3.1 Vacuum Connection



DANGER



DANGER: overpressure in the vacuum system >1 bar

Injury caused by released parts and harm caused by escaping process gases can result if clamps are opened while the vacuum system is pressurized.

Do not open any clamps while the vacuum system is pressurized. Use the type of clamps which are suited to overpressure.



Caution



Caution: vacuum component

Dirt and damages impair the function of the vacuum component.

When handling vacuum components, take appropriate measures to ensure cleanliness and prevent damages.



Caution



Caution: dirt sensitive area

Touching the product or parts thereof with bare hands increases the desorption rate.

Always wear clean, lint-free gloves and use clean tools when working in this area.

Remove the protective lids and install the product to the vacuum system.

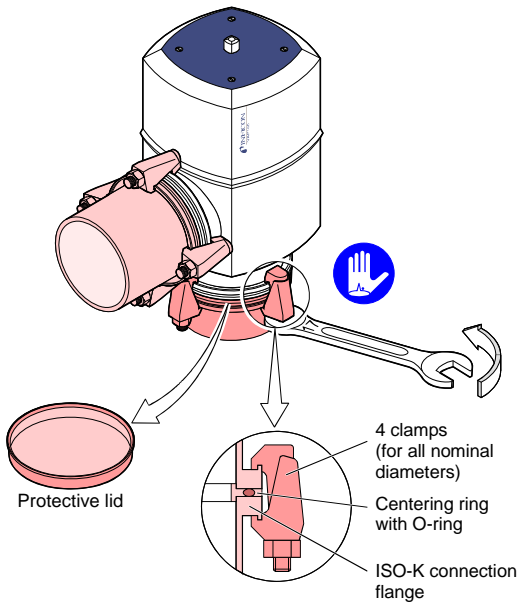

Keep the protective lids.

3.2 Compressed Air Connection



DANGER



DANGER: compressed air
 Unprofessionally handling compressed air can cause physical injury.
 Adhere to the relevant regulations and take the necessary precautions when handling compressed air.



DANGER



DANGER: moving parts
 When the product is connected to the supply media, parts can start moving. Moving parts can catch parts of the body and cause injuries.

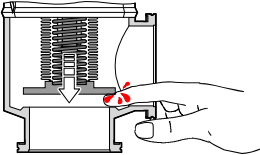

The connection to the compressed air supply may only be established if

- the compressed air line is de-energized
- the product is installed in a vacuum system or
- the moving parts are protected to avoid accidental contact.

 The plastic tube must meet the following specifications:

- OD 6 mm
- bursting pressure ≥ 10 bar overpressure
- material: PA soft or PU

 To ensure leak tightness of the instant push-in fitting

- cut the plastic tube perpendicularly
- make sure the outside of the plastic tube is not damaged.

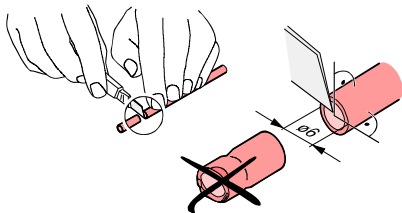

 The compressed air must meet the following specifications:

- purity classes 2 4 1 (ISO 8573-1)
- 4 ... 8 bar overpressure

Compressed Air Inlet

Push the tube into the instant push-in fitting until the mechanical stop is reached. Check that it is correctly mounted by slightly pulling.

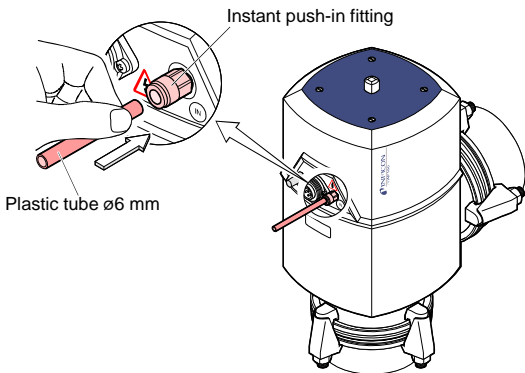

Compressed Air Outlet

If necessary, unscrew the silencer and screw in the enclosed instant push-in fitting ($\varnothing 6$ mm) for educting the compressed air. Push the tube into the instant push-in fitting until the mechanical stop is reached. Check that it is correctly mounted by slightly pulling.

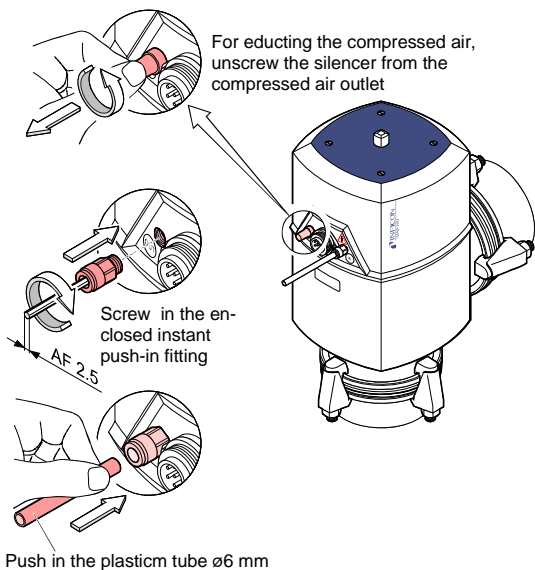

3.3 Electrical Connection



DANGER



DANGER: moving parts
When the product is connected to the supply media, parts can start moving. Moving parts can catch parts of the body and cause injuries.

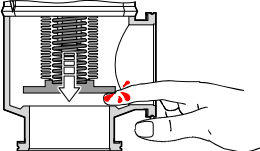

The connection to the power supply may only be established if

- the power supply is de-energized
- the product is installed in a vacuum system or
- the moving parts are protected to avoid accidental contact.



Caution



Caution: line voltage
Incorrect voltages can destroy the product.
The local line voltage ratings must correspond to the nominal voltage of the product (→ product nameplate).



The cable must meet the following specifications:

- flexible
- conductor cross-section 0.75 mm^2
- cable cross-section 10 mm
- 7-pin with protective conductor

1

Prepare the connector.

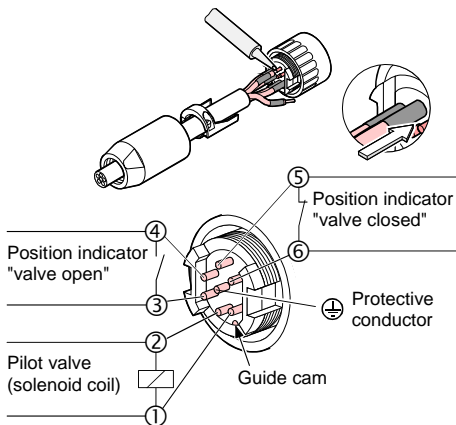



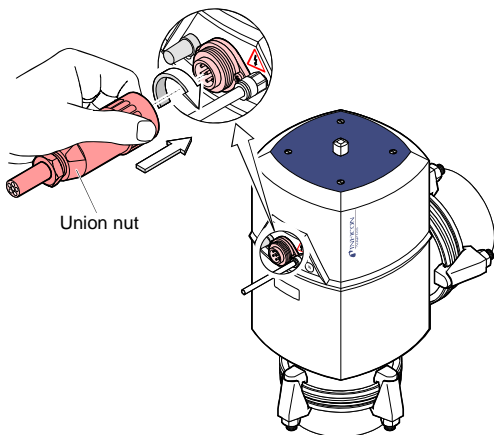



- 2** Plug in the connector and secure it with the union nut.

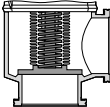

4 Operation

The product is ready for operation as soon as it has been installed.

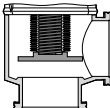
Valve position

Valve position	Compressed air	Pilot valve	Position indicator
closed 	admitted	deactivated	
	not admitted	activated	
	not admitted	deactivated	
open 	admitted	activated	

5 Deinstallation

Precondition

Vacuum system vented.

5.1 Electrical Connection



DANGER



DANGER: moving parts
When the product is disconnected from the supply media, parts can start moving. Moving parts can catch parts of the body and cause injuries.

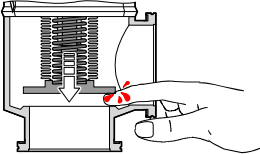

The product may only be disconnected from the power supply if

- the product is installed in a vacuum system or
- the moving parts are protected to avoid accidental contact.



Before connecting or disconnecting the product, turn off the control system.

Loosen the connector and unplug it.

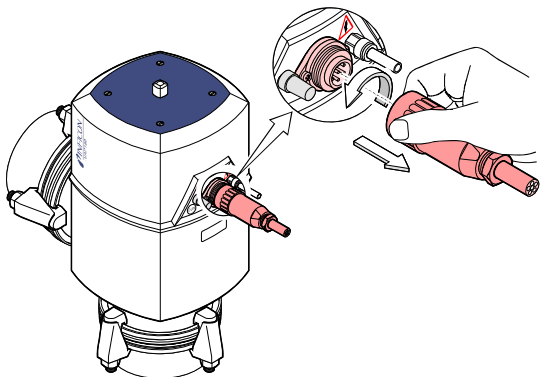

5.2 Compressed Air Connection

 **DANGER**



DANGER: compressed air

Physical injury can result if a pressurized compressed air line is disconnected.

Before doing any work, turn off the compressed air supply and relieve the compressed air lines.

 **DANGER**



DANGER: moving parts

When the product is disconnected from the supply media, parts can start moving. Moving parts can catch parts of the body and cause injuries.

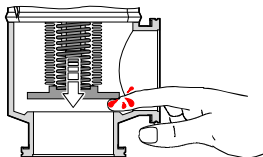

The product may only be disconnected from the compressed air supply if

- the product is installed in a vacuum system or
- the moving parts are protected to avoid accidental contact.

Pull out the tube while depressing the thrust ring.

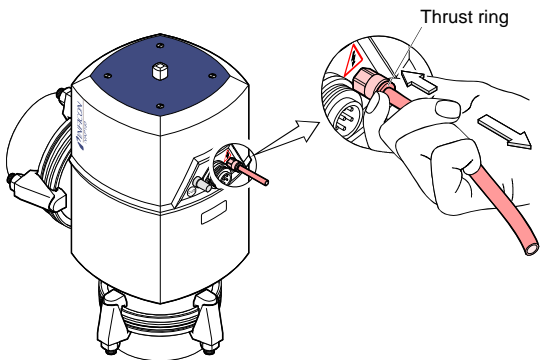

5.3 Vacuum Connection



DANGER



DANGER: contaminated parts
 Contaminated parts can be detrimental to health and environment.

Before beginning to work, find out whether any parts are contaminated. Adhere to the relevant regulations and take the necessary precautions when handling contaminated parts.



Caution



Caution: vacuum component
 Dirt and damages impair the function of the vacuum component.

When handling vacuum components, take appropriate measures to ensure cleanliness and prevent damages.



Caution



Caution: dirt sensitive area
 Touching the product or parts thereof with bare hands increases the desorption rate.

Always wear clean, lint-free gloves and use clean tools when working in this area.

Disassemble the clamp flange connections and place the protective lids.

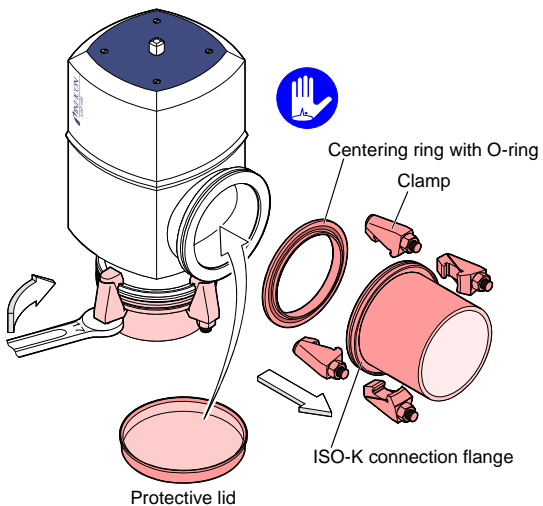

6 Maintenance / Repair

→  sinb10e1

7 Returning the Product



WARNING



WARNING: forwarding contaminated products

Contaminated products (e.g. radioactive, toxic, caustic or biological hazard) can be detrimental to health and environment.

Products returned to INFICON should preferably be free of harmful substances. Adhere to the forwarding regulations of all involved countries and forwarding companies and enclose a duly completed declaration of contamination.

Products that are not clearly declared as "free of harmful substances" are decontaminated at the expense of the customer. Products not accompanied by a duly completed declaration of contamination are returned to the sender at his own expense.

8 Disposal

DANGER



DANGER: contaminated parts

Contaminated parts can be detrimental to health and environment.

Before beginning to work, find out whether any parts are contaminated. Adhere to the relevant regulations and take the necessary precautions when handling contaminated parts.

WARNING



WARNING: substances detrimental to the environment

Products or parts thereof (mechanical and electric components, operating fluids etc.) can be detrimental to the environment.

Dispose of such substances in accordance with the relevant local regulations.

Separating the components

After disassembling the product, separate its components according to the following criteria:

- Contaminated components
Contaminated components (radioactive, toxic, caustic, microbiological hazard etc.) must be decontaminated in accordance with the relevant national regulations, separated according to their materials, and disposed of.
- Other components
Such components must be separated according to their materials and recycled.

Declaration of Incorporation

as defined by the Directive relating to machinery 2006/42/EC, Appendix IIB

We, INFICON, hereby declare that the partly completed machinery mentioned below

- must not be put into operation until evidence is given that the final machinery into which that partly completed machinery shall be installed is in conformity with the provisions of the EC Directive relating to machinery
- fulfill the appropriate essential requirements in accordance with Annex I of the EC Directive relating to machinery

We also declare that the relevant technical documentation is compiled in accordance with part B of Annex VII and that the relevant technical documentation will be transmitted in response to a reasonable request by the national authorities in printed form or in electronic form (pdf).

Product

Angle Valve
VAP160-A Reed

Standards

Harmonized and international/national standards and specifications:

- EN ISO 12100-1:2003 (Safety of machinery)
- EN ISO 12100-1:2003/A1:2009 (Safety of machinery)
- EN ISO 12100-2:2003 (Safety of machinery)
- EN ISO 12100-2:2003/A1:2009 (Safety of machinery)
- EN ISO 13857:2008 Safety distances to prevent hazard zones being reached by upper and lower limbs
- EN 349:1993 + A1:2008 (Minimum gaps to avoid crushing of parts of the human body)

- EN 60204-1:2006 (Electrical equipment of machines)
- EN 60204-1:2006/A1:2009 (Electrical equipment of machines)

Authorized representative for documentation

INFICON AG, Director Technology, Alte Landstrasse 6,
LI-9496 Balzers

Manufacturer / signatures

INFICON AG, Alte Landstrasse 6, LI-9496 Balzers

17 March 2010



Dr. Urs Wälchli
Managing Director

17 March 2010



Marco Kern
Product Manager

Notes

Original: German simb10d1 (2010-03)



si mb10e1



LI-9496 Balzers
Liechtenstein
Tel +423 / 388 3111
Fax +423 / 388 3700
reachus@inficon.com

www.inficon.com