

Safety Valves

VSM063 ... 100-AA

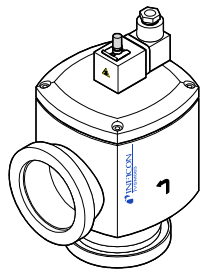

Instruction Sheet
Incl. Manufacturer's Declaration
sima83e1-b (0202)

Product Identification

In all communications with Inficon, please specify the information on the product nameplate. For convenient reference copy that information into the space provided below:

INFICON AG, LI-9496 Balzers
Model: _____
PN: _____
SN: _____
V: _____ W: _____

Validity

This document applies to products with the following part numbers:

253-030	(DN 63 ISO-K	24 VDC ±10%)
253-032	(DN 63 ISO-K	90 ... 126 VAC / 50 ... 60 Hz)
253-034	(DN 63 ISO-K	180 ... 253 VAC / 50 ... 60 Hz)
253-040	(DN 100 ISO-K	24 VDC ±10%)
253-042	(DN 100 ISO-K	90 ... 126 VAC / 50 ... 60 Hz)
253-044	(DN 100 ISO-K	180 ... 253 VAC / 50 ... 60 Hz)

The part number (PN) can be taken from the product nameplate.

If not indicated otherwise in the legends, the illustrations in this document correspond to the Safety valve with the nominal diameter DN 63 ISO-K. They apply to the Safety valve with the nominal diameter DN 100 ISO-K by analogy.

We reserve the right to make technical changes without prior notice.

All dimensions are indicated in mm.

Intended Use

When the backing pump is switched off or in the event of a power failure, the Safety valve shuts off the vacuum system and vents the backing pump.

Overview

The Safety valve consists of the following modules:

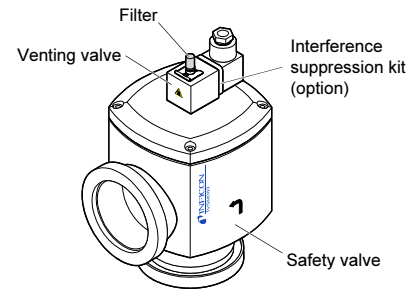

For prevention of interference with sensitive equipment near the Safety valve, an optional interference suppression kit can be built in.

Interference suppression kit	Ordering number
100 ... 230 VAC	215-406
24 VDC	215-405

Liability and Warranty

Inficon assumes no liability and the warranty becomes null and void if the end-user or third parties

- disregard the information in this document
- use the product in a non-conforming manner
- make any kind of interventions (modifications, alterations etc.) on the product
- use the product with accessories and options not listed in the corresponding product documentation.

The end-user assumes the responsibility in conjunction with the process media used.

Technical Data

Type	VSM ...	063-AA	100-AA
Connection flanges		DN 63 ISO-K	DN 100 ISO-K
Nominal voltage		see product nameplate	
Nominal power		2.5 W	
DC		5 / 3.7 VA (pickup/holding)	
AC			
Type of connection		cable socket according to DIN 43650	
Duty cycle		100%	
Type of protection		IP 65 according to DIN 40 050	
Conductance ¹⁾		126 l/s	300 l/s
Installation angle		any	
Tightness housing		<1×10 ⁻⁹ mbar l/s	
valve plate		<1×10 ⁻⁵ mbar l/s	
Pressure range		1×10 ⁻⁸ mbar ... 1 bar (absolute)	
Pressure difference Δp for closing		>150 mbar	
for opening the safety valve ²⁾		<150 mbar	
Opening time		<30 s	
Closing/response time		<100 ms / <50 ms	
Temperatures ambience		5 °C ... 50 °C	
Solenoid coil ambience 20 °C		<55 °C	
ambience 50 °C		<80 °C	
Bakeout housing		<60 °C	
actuator		<50 °C	
Materials housing seals		aluminum FPM	
Weight		2.4 kg	5.1 kg

¹⁾ For air with molecular flow
²⁾ See section "Operation"

Dimensions [mm]

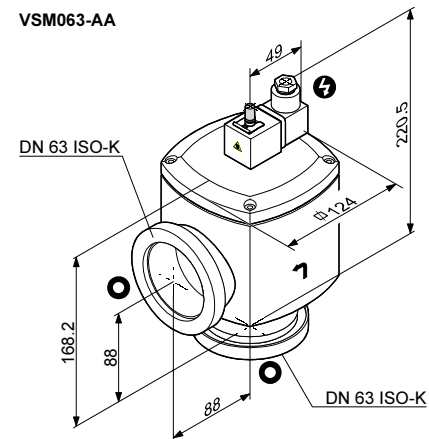

VSM100-AA

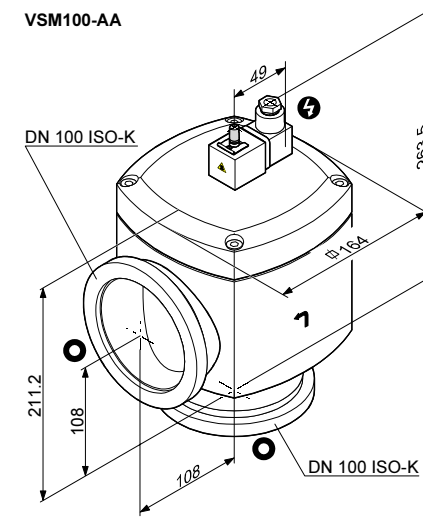

- Flow direction
- ⚡ Power connection
- ⊙ Protective lid

Installation

Voltage Rating

Caution
Caution: supply voltage
Incorrect supply voltages can destroy the product.
The supply voltage rating must correspond to the nominal voltage of the product (→ product nameplate). If they do not correspond, please contact your local Inficon service center.

Vacuum Connection

Caution
Caution: vacuum component
Dirt and damages impair the function of the vacuum component.
When handling vacuum components, take appropriate measures to ensure cleanliness and prevent damages.

Caution
Caution: dirt sensitive area
Touching the product or parts thereof with bare hands increases the desorption rate.
Always wear clean, lint-free gloves and use clean tools when working in this area.

Remove the protective lids and connect the Safety valve to the backing pump and vacuum system.

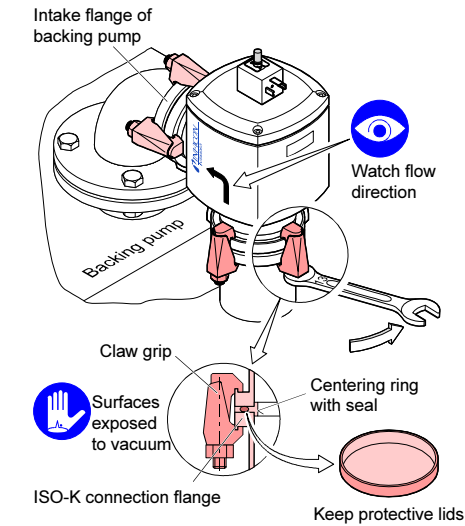

Electrical Connection

Connect the solenoid coil of the venting valve in parallel with the drive motor of the backing pump.

Example of a circuit diagram

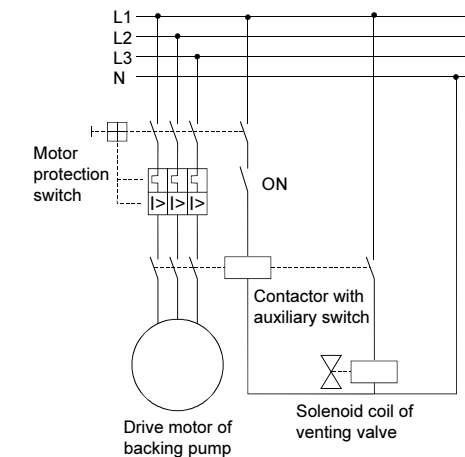

Connecting the solenoid coil of the venting valve

- 1 Connect the cable socket.
For the 24 VDC version, the polarity need not be taken into consideration. For safety reasons, we recommend grounding the 24 VDC version, too.

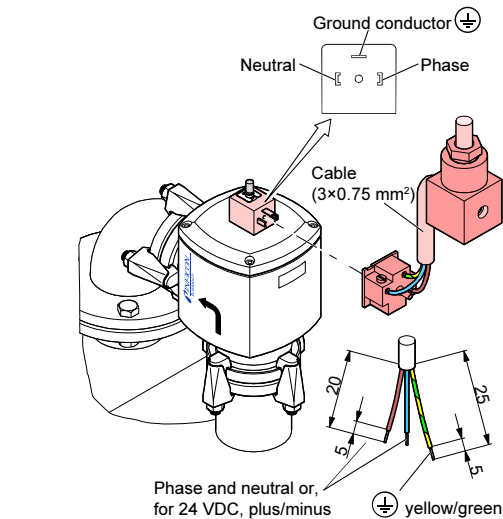

- 2 Connect the solenoid coil to the supply voltage.

STOP DANGER
Caution: mains voltage/supply voltage
Products that are not professionally connected to ground can be extremely hazardous in the event of a fault.
Use only a 3-conductor power cable with protective ground. The power connector may only be plugged into a socket with a protective ground. The protection must not be nullified by an extension cable without protective ground.

Before connecting or disconnecting the Safety valve, turn off the control system.

- Plug in the cable socket **without using an interference suppression kit** and tighten the locking screw ...

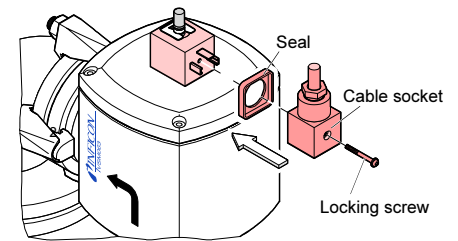

- ... or plug in the cable socket **after having inserted an interference suppression kit** and tighten the locking screw.

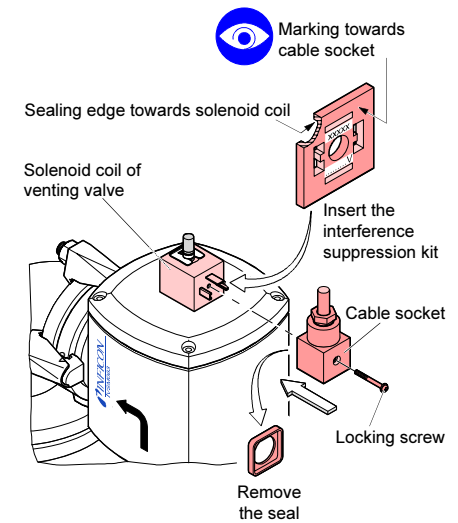

Operation

The Safety valve is ready for operation as soon as it has been installed.

STOP
DANGER

Caution: hot surface
Touching the hot surface (>55 °C) can cause burns.
Wear protective gloves.

Idle position

When the backing pump and vacuum system are under atmospheric pressure, both the venting and safety valve are open.

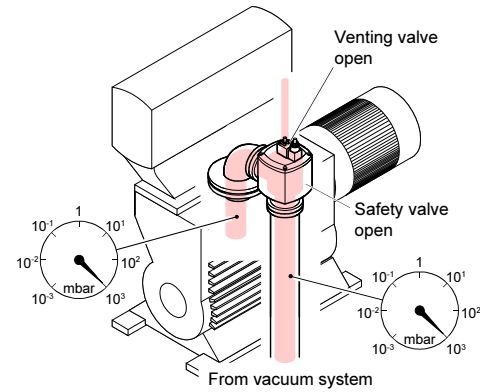

Backing pump in operation

When the backing pump is switched on, the venting valve is closed and the vacuum system is evacuated.

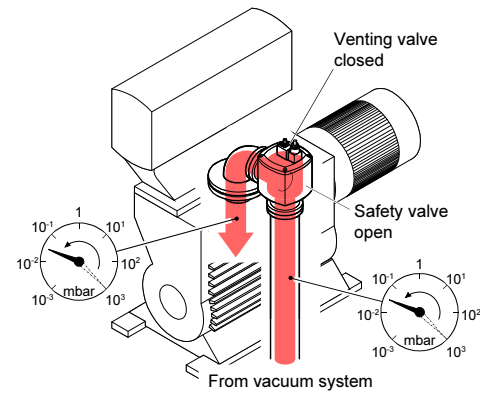

Backing pump out of operation

When the backing pump is switched off or in the event of a power failure, the venting valve is opened. Due to the pressure difference between the inrushing air and the evacuated vacuum system, the safety valve is closed. Through the open venting valve, air is admitted to the backing pump.

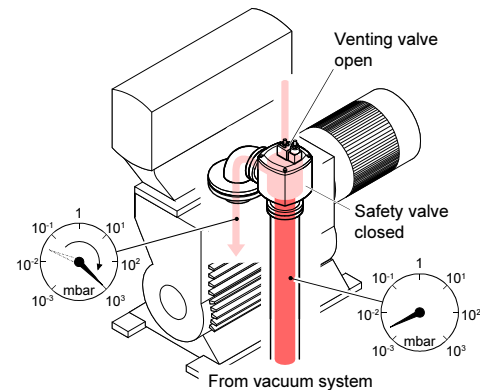

Backing pump again in operation

When the backing pump is switched on again, the venting valve is closed. The safety valve is evacuated ...

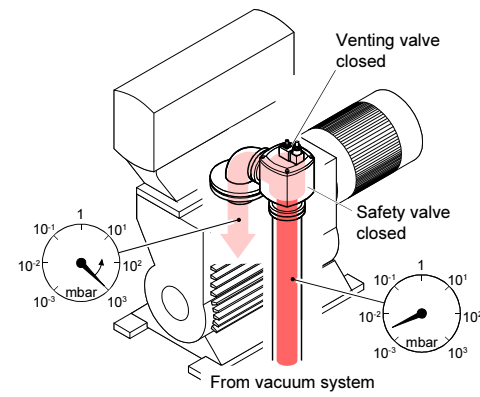

... and is opened when the pressure difference Δp to the pressure in the vacuum system drops below 150 mbar.

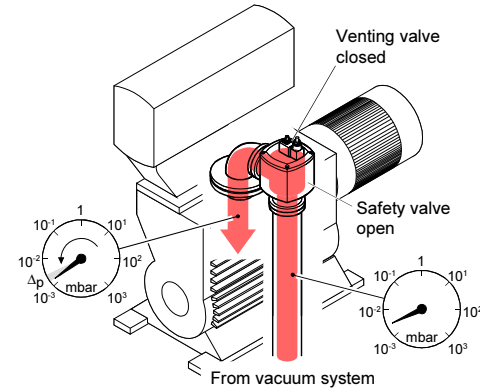

Deinstallation

STOP
DANGER

Caution: contaminated parts
Contaminated parts can be detrimental to health and environment.
Before beginning to work, find out whether any parts are contaminated. Adhere to the relevant regulations and take the necessary precautions when handling contaminated parts.

!
Caution

Caution: vacuum component
Dirt and damages impair the function of the vacuum component.
When handling vacuum components, take appropriate measures to ensure cleanliness and prevent damages.

!
Caution

Caution: dirt sensitive area
Touching the product or parts thereof with bare hands increases the desorption rate.
Always wear clean, lint-free gloves and use clean tools when working in this area.

Preconditions

- Vacuum system vented
- Control system turned off
- Safety valve and venting valve cooled down to <55 °C

Procedure

- 1 Unfasten the locking screw and unplug the cable socket.

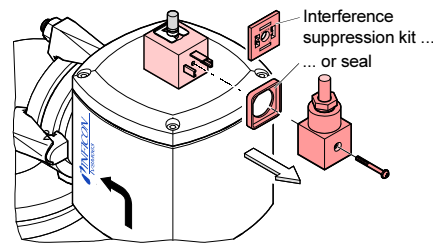

- 2 Disconnect the clamping flange fittings and put the protective lids in place.

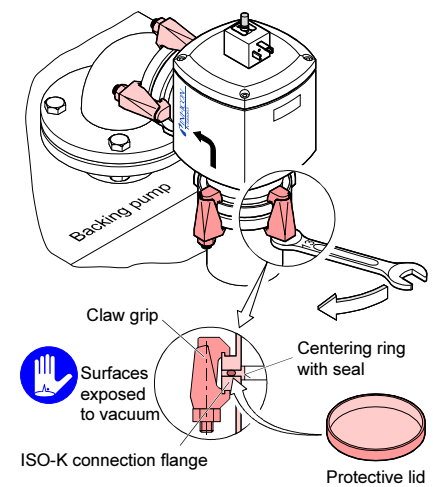

Maintenance, Repair

See Operating Manual sina83e1, which can be downloaded from our website.

Returning the Product

!
WARNING

Caution: forwarding contaminated products
Contaminated products (e.g. radioactive, toxic, caustic or biological hazard) can be detrimental to health and environment.
Products returned to Inficon should preferably be free of harmful substances. Adhere to the forwarding regulations of all involved countries and forwarding companies and enclose a duly completed declaration of contamination.

Products that are not clearly declared as "free of harmful substances" are decontaminated at the expense of the customer.

Products not accompanied by a duly completed declaration of contamination are returned to the sender at his own expense.

Disposal

STOP
DANGER

Caution: contaminated parts
Contaminated parts can be detrimental to health and environment.
Before beginning to work, find out whether any parts are contaminated. Adhere to the relevant regulations and take the necessary precautions when handling contaminated parts.

Separating the components

After disassembling the product, separate its components according to the following criteria:

- Contaminated components
Contaminated components (radioactive, toxic, caustic, or biological hazard etc.) must be decontaminated in accordance with the relevant national regulations, separated according to their materials, and disposed of.
- Other components
Such components must be separated according to their materials and recycled.

Declaration of Contamination

The service, repair, and/or disposal of vacuum equipment and components will only be carried out if a correctly completed declaration has been submitted. Non-completion will result in delay. This declaration may only be completed (in block letters) and signed by authorized and qualified staff.

- 1 **Description of product**
Type _____
Part number _____
Serial number _____
- 2 **Reason for return**

- 3 **Operating fluid(s) used**
(Must be drained before shipping.)

- 4 **Process related contamination of product:**

toxic	no <input type="checkbox"/> 1) yes <input type="checkbox"/>	<div style="border: 2px solid red; padding: 5px; display: inline-block;"> ! </div> <p style="font-size: 0.8em; margin-top: 5px;">2) Products thus contaminated will not be accepted without written evidence of decontamination!</p>
corrosive	no <input type="checkbox"/> 1) yes <input type="checkbox"/>	
biological hazard	no <input type="checkbox"/> 1) yes <input type="checkbox"/> 2)	
explosive	no <input type="checkbox"/> 1) yes <input type="checkbox"/> 2)	
radioactive	no <input type="checkbox"/> 1) yes <input type="checkbox"/> 2)	
other harmful substances	no <input type="checkbox"/> 1) yes <input type="checkbox"/>	

1) or not containing any amount of hazardous residues that exceed the permissible exposure limits

yes The product is free of any substances which are damaging to health
- 5 **Harmful substances, gases and/or by-products**
Please list all substances, gases, and by-products which the product may have come into contact with:

Trade/product name manufacturer	Chemical name (or symbol)

Precautions associated with substance	Action if human contact

- 6 **Legally binding declaration:**
I/we hereby declare that the information on this form is complete and accurate and that I/we will assume any further costs that may arise. The contaminated product will be dispatched in accordance with the applicable regulations.

Organization/company _____
Address _____
Post code, place _____
Phone _____ Fax _____
Email _____
Name _____
Company stamp _____
Date and legally binding signature _____

This form can be downloaded from our website.
Copies: Original for addressee
1 copy for accompanying documents
1 copy for file of sender

Manufacturer's Declaration

as defined by the Directive relating to machinery 98/37/EC, Appendix IIb.

We, Inficon, hereby declare that putting the incomplete equipment mentioned below into operation is not permitted until evidence is given that the system into which that incomplete equipment shall be installed is in accordance with the provisions of the EC Directive relating to machinery. We also declare that the equipment mentioned below complies with the provisions of the Directive relating to electrical equipment designed for use within certain voltage limits 73/23/EEC.

Safety Valves VSM063 ... 100-AA

Part numbers

253-030 253-040
253-032 253-042
253-034 253-044

Standards

Harmonized and international/national standards and specifications:

- EN 292-1/2 (Safety of machinery)
- EN 294 (Safety distances to prevent danger zones being reached by the upper limbs)
- EN 60204-1 (Electrical equipment of machines)
- DIN 28404 (ISO-K small flange connections)
- ISO 1609 (Vacuum technology, flange dimensions)
- ISO 9803 (Pipeline fittings, mounting dimensions)

Signatures

INFICON AG, Liechtenstein

9 October 2001

Hans-Christoph Gehlhar
Product Manager

9 October 2001

Dr. Georg Sele
Technical Support Manager
Quality Representative



LI-9496 Balzers
Liechtenstein
Tel +423 / 388 3111
Fax +423 / 388 3700
reach.liechtenstein@inficon.com
www.inficon.com