

Inline Valve

pneumatically actuated
bellows sealed
with position indicator and pilot valve
normally open

VIP016 ... 040-X

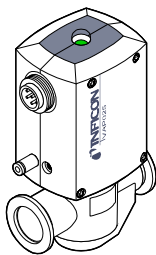

Instruction Sheet
Incl. Manufacturer's Declaration

sima61e1-b (0210)

Product Identification

In all communications with INFICON, please specify the information on the product nameplate. For convenient reference copy that information into the space provided below.

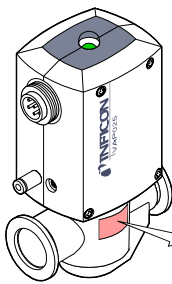

INFICON, FL - 9496 Balzers
Typ: _____
No: _____
F-No: _____

Nominal voltage

Validity

This document applies to products with the following part numbers:

DN 16 ISO-KF	DN 25 ISO-KF	DN 40 ISO-KF	Nominal voltage (pilot valve) N.O.
250-316	250-336	250-356	24 VDC (=)

The part number can be taken from the product nameplate.

If not indicated otherwise in the legends, the illustrations in this document correspond to the valve with the nominal diameter DN 25 ISO-KF. They apply to valves with other nominal diameters by analogy.

We reserve the right to make technical changes without prior notice.

Intended Use

The inline valves are used as shut-off and venting devices for vacuum applications.

Description

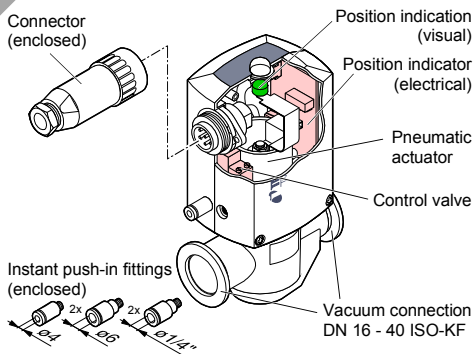

Functional principle

When the pilot valve is activated, the inline valve is closed by the pressure spring. The position indicator is invisible.

When the pilot valve is deactivated, the inline valve is opened by the pneumatic actuator. The green position indicator becomes visible.

The final positions can be polled by the electrical position indicator.

Safety

Symbols Used

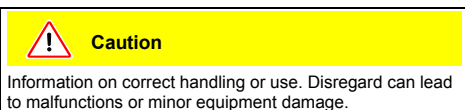
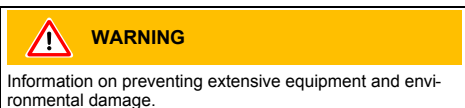
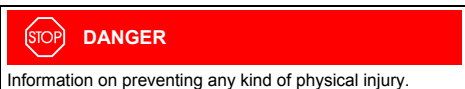

→²⁰ Dimensions in mm

General Safety Instructions

- Adhere to the applicable regulations and take the necessary precautions for the process media used. Consider possible reactions between the materials and the process media.
- Adhere to the applicable regulations and take the necessary precautions for all work you are going to do and consider the safety instructions in this document.
- Before beginning to work, find out whether any vacuum components are contaminated. Adhere to the relevant regulations and take the necessary precautions when handling contaminated parts.

Communicate the safety instructions to all other users.

Liability and Warranty

INFICON assumes no liability and the warranty becomes null and void if end-user or third parties

- disregard the information in this document
- use the product in a non-conforming manner
- make any kind of interventions (modifications, alterations etc.) on the product
- use the product with accessories and options not listed in the corresponding product documentation.

The end-user assumes the responsibility in conjunction with the process media used.

Technical Data

Pilot valve connection type	soldered joints normally open		
nominal voltage	see product nameplate		
power	1 W		
duty cycle	100%		
nominal diameter	0.42 mm		
Position indicator connection rating	soldered joints 250 VAC / 25 VA / 0.1 A 50 VDC / 12.5 W / 0.25 A		
Connection flange	DN 16 ISO-KF	DN 25 ISO-KF	DN 40 ISO-KF
Actuation	opening: pneumatic closing: by pressure spring		
Compressed air supply tube connection	ø 4 mm, ø 6 mm or ø 1/4"		
pressure range (overpressure)	3 ... 5 bar	3 ... 6 bar	
piston displacement	5.5 cm ³	12.1 cm ³	26.2 cm ³
Stroke of the valve plate	5 mm	10 mm	14 mm
Conductance ¹⁾	2.5 l/s	8 l/s	20 l/s
Switching frequency ²⁾	100 / min	100 / min	75 / min
Opening time ²⁾	100 ms	110 ms	150 ms
Closing time ²⁾	200 ms	290 ms	250 ms
Cycle life ³⁾	10 million		
Tightness	1×10 ⁻⁹ mbar l/s		
Pressure range min.	1×10 ⁻⁸ mbar		
Pressure range max. (abs.)	4 bar	2.5 bar	
Pressure difference Δp in closing direction	4 bar	2 bar	
in opening direction	2 bar	1.5 bar	
Opens to a pressure difference Δp ⁴⁾	4 bar	2 bar	
Temperatures	0 °C ... 50 °C		
ambiance			
bakeout	150 °C		
housing	50 °C		
actuator	50 °C		
pilot valve	50 °C		
Type of protection	IP 50 according to DIN 40 050		
Protection class	II		
Installation angle	any		
Flow direction	any		
Materials			
housing	1.4301		
bellows / valve plate	1.4541 / 1.4301		
pressure spring			
DN 16 + 25 ISO-KF	1.4301		
DN 40 ISO-KF	1.1200		
seals	FPM		
shell	PBTP		
cylinder unit	PBTP		
protective lids	PE		
packing material	carton box, PE, PU		
Weight	0.44 kg	0.9 kg	1.52 kg

¹⁾ For air with molecular flow

²⁾ With pressure difference Δp=0, compressed air = 5 bar (overpressure)

³⁾ Cycles without expendable parts (seals) and under clean operating conditions

⁴⁾ Compressed air = 5 bar (overpressure)

Dimensions

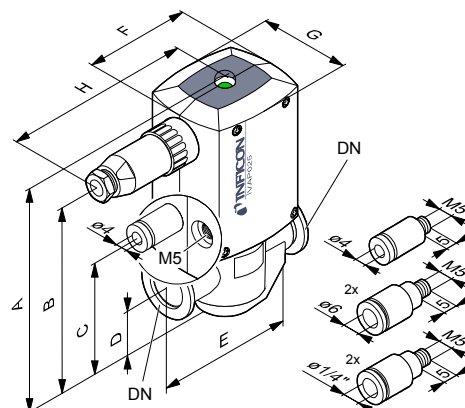

DN	A	B	C	D	E	F	G	H
DN 16 ISO-KF	135.9	108.9	36.4	22	80	60	51	100
DN 25 ISO-KF	157.4	128.9	74	31.5	100	74	63	108
DN 40 ISO-KF	177	147.8	92.5	45.5	130	98	83	120

Installation

Vacuum Connection

Skilled personnel



The vacuum connection may only be established by persons who have suitable technical training and the necessary experience or who have been instructed by the end-user of the product.



DANGER
Caution: overpressure in the vacuum system > 1 bar

Injury caused by released parts and harm caused by escaping process gases can result if clamps are opened while the vacuum system is pressurized.

Do not open any clamps while the vacuum system is pressurized. Use the type clamps which are suited to overpressure.



Caution

Caution: dirt sensitive area

Touching the product or parts thereof with one's bare hands increases the desorption rate.

Always wear clean, lint-free gloves and use clean tools when working in this area.



Caution

Caution: vacuum component

Dirt and damages impair the function of the vacuum component.

When handling vacuum components, take appropriate measures to ensure cleanliness and prevent damages.



Caution

Keep the protective lids and put them in place again when removing the product from the vacuum system.

Remove the protective lids and install the valve to the vacuum system by means of the small flange fittings. Any installation angle and flow direction may be chosen.

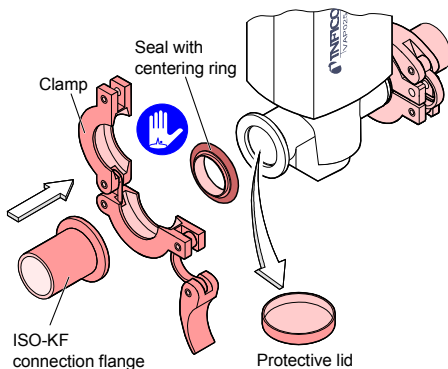

Compressed Air Connection

Skilled personnel



The compressed air connection may only be established by persons who have suitable technical training and the necessary experience or who have been instructed by the end-user of the product.



Caution

The plastic tube must meet the following specifications:

- \varnothing 4 mm, \varnothing 6 mm or \varnothing 1/4"
- bursting pressure \geq 10 bar overpressure
- material: PA soft or PU.

Caution



Specifications for the compressed air:

- free of particles >5 μ m
- DN 16 and DN 25: 3 ... 5 bar overpressure
- DN 40: 3 ... 6 bar overpressure
- dry, free of oil or containing oil (Keep using the same quality.)

If using compressed air which contains oil, dispose of it in accordance with the relevant regulations.

Caution



To ensure leak tightness of the instant push-in fitting

- cut the plastic tube square
- make sure the outside of the plastic tube is not damaged.

Caution



Caution: plastic thread

The plastic thread is damaged by tilting or overturning the instant push-in fitting.

- use the enclosed instant push-in fitting (with extra-long thread) only.
- screw in the instant push-in fitting without tilting it and without exceeding the tightening torque of 0.5 Nm.

Compressed Air Inlet

Caution



Contrary to the illustration below, the compressed air inlets and outlets of the angle valves with vacuum connection DN 40 ISO-KF and serial number (F-No) from 110 are reversed in position.

If you wish to connect a \varnothing 6 mm, or \varnothing 1/4" plastic tube, exchange the instant push-in fitting.

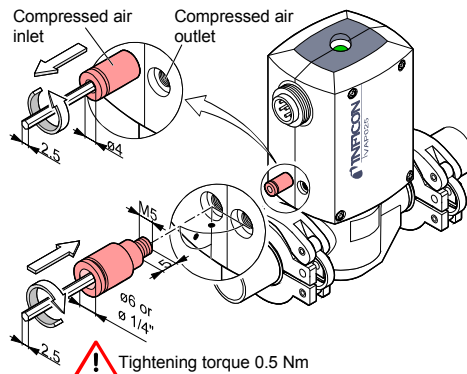

Insert the tube into the instant push-in fitting until the mechanical stop is reached. Check that it is correctly mounted by slightly pulling.

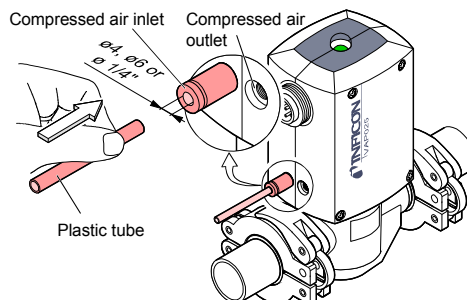

Compressed Air Outlet

Caution



Contrary to the illustration below, the compressed air inlets and outlets of the angle valves with vacuum connection DN 40 ISO-KF and serial number (F-No) from 110 are reversed in position.

Screw in the enclosed instant push-in fitting for exhausting the compressed air if necessary. Push the tube into the instant push-in fitting until the mechanical stop is reached. Check that it is correctly mounted by slightly pulling.

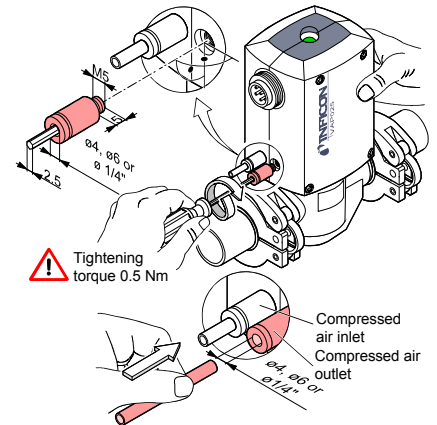

Electrical Connection

Skilled personnel



The electrical connection, in accordance with the VDE 0100 guidelines, may be made only by a licensed electrician, qualified as per VDE 0105. The line cables shall be isolated from the line supply during all electrical work.

WARNING



Caution: mains voltage

The pilot valve can get destroyed if a wrong mains voltage is applied.

The local mains power rating must correspond with the nominal voltage of the pilot valve (see product nameplate). If they do not correspond, exchange the pilot valve (\rightarrow Further information).

Caution



The cable must meet the following specifications:

- flexible
- conductor cross-section \leq 0.75 mm²
- cable diameter \leq 10 mm
- 6-pole without protective conductor or 7-pole with protective conductor.

Preparing the connector

- Slide the screw fitting, connector housing, and strain relief on the cable.

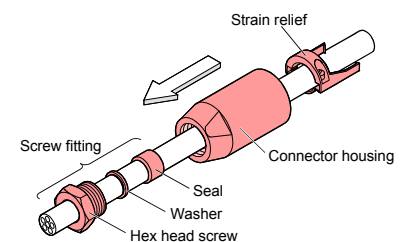

(0210)

- 2 Skin the cable and mount the insulating sleeves if required.

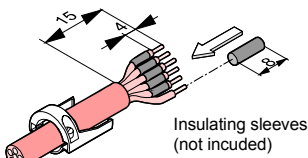

- 3 Solder the cable. Slide the insulating sleeve over the soldered connection. The polarity of the pilot valve (solenoid coil) need not be taken into consideration.

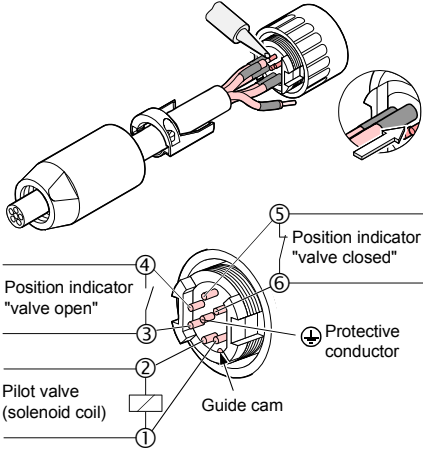

- 4 Tighten the strain relief and insert it (it will catch).

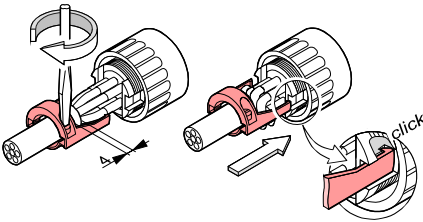

- 5 Reassemble the connector and tighten the screw fitting (width across 17 mm).

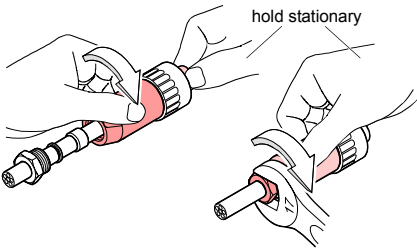

- 6 Plug in the connector and secure it with the union nut.

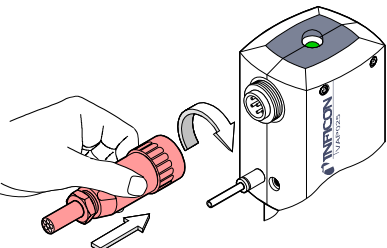

Operation

The product is ready for operation as soon as it has been installed.

Valve position	Compressed air	Control valve	Position indication
closed 	available	activated	
	not available	activated	
	not available	deactivated	
open 	available	deactivated	

Pressure range:

DN 16+25 ISO-KF: 1×10^{-8} mbar ... 4 bar (absolute)
DN 40 ISO-KF: 1×10^{-8} mbar ... 2.5 bar (absolute)

Pressure difference Δp in closing direction

Caution

Caution: pressure difference Δp

At $\Delta p > 4$ bar (DN 16+25 ISO-KF) and $\Delta p > 2$ bar (DN 40 ISO-KF) the valve may no longer be tight. Avoid bigger pressure differences.

Pressure difference Δp in opening direction

Caution

Caution: pressure difference Δp

With $\Delta p > 2$ bar (DN 16+25 ISO-KF) and $\Delta p > 1.5$ bar (DN 40 ISO-KF) the valve is opened. Avoid bigger pressure differences.

Opening against a pressure difference Δp

Caution

Caution: pressure difference Δp

With $\Delta p > 4$ bar (DN 16+25 ISO-KF) and $\Delta p > 2$ bar (DN 40 ISO-KF) the valve cannot open. Avoid bigger pressure differences.

Deinstallation

Electrical Connection

Skilled personnel

The electrical power must be disconnected by a skilled electrician.

Caution



The control system must be disconnected from the power source before any connection to the product is made or interrupted.

Loosen the connector and unplug it.

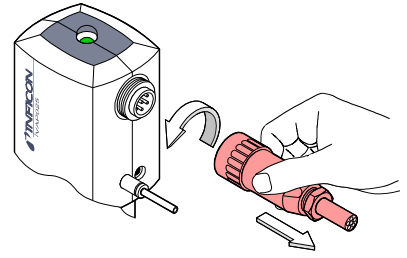

Compressed air connection

Skilled personnel

The compressed air may only be disconnected by persons who have suitable technical training and the necessary experience or who have been instructed by the end-user of the product.

DANGER

Caution: compressed air
Physical injury can result if a pressurized compressed air line is disconnected. Before doing any work, turn off the compressed air supply and relieve the compressed air lines.

Pull out the tube while depressing the thrust ring.

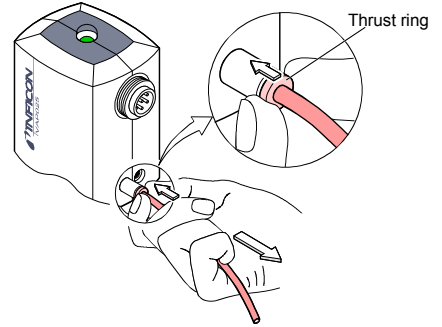

Vacuum connection

Skilled personnel

The vacuum connection may only be disassembled by persons who have suitable technical training and the necessary experience or who have been instructed by the end-user of the product.

DANGER

Caution: contaminated parts
Contaminated parts can be detrimental to health and environment. Before beginning to work, find out whether any parts are contaminated. Adhere to the relevant regulations and take the necessary precautions when handling contaminated parts.

Caution

Caution: vacuum component
Dirt and damages impair the function of the vacuum component. When handling vacuum components, take appropriate measures to ensure cleanliness and prevent damages.

Caution

Caution: dirt sensitive area
Touching the product or parts thereof with one's bare hands increases the desorption rate.
Always wear clean, lint-free gloves and use clean tools when working in this area.

Vent the vacuum system and disassemble the small flange connection. Place the protective lid.

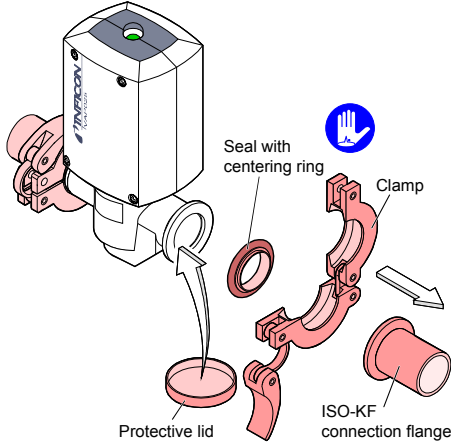

Further information

Refer to the Operating manual with regard to maintenance, repair, and spare parts.

The Operating manual sina61e1

- can be downloaded from our website or
- ordered at INFICON.

Returning the product

WARNING

Caution: forwarding contaminated products
Contaminated products (e.g. radioactive, toxic, caustic or microbiological hazard) can be detrimental to health and environment.
Products returned to INFICON should preferably be free of harmful substances. Adhere to the forwarding regulations of all involved countries and forwarding companies and enclose a duly completed declaration of contamination.

Products that are not clearly declared as "free of harmful substances" are decontaminated at the expense of the customer.

Products not accompanied by a duly completed declaration of contamination are returned to the sender at his own expense.

Disposal

DANGER

Caution: contaminated parts
Contaminated parts can be detrimental to health and environment.
Before beginning to work, find out whether any parts are contaminated. Adhere to the relevant regulations and take the necessary precautions when handling contaminated parts.

Separating the components

After disassembling the product, separate its components according to the following criteria:

- Contaminated components
Contaminated components (radioactive, toxic, caustic, or biological hazard etc.) must be decontaminated in accordance with the relevant national regulations, separated according to their materials, and disposed of.
- Other components
Such components must be separated according to their materials and recycled.

Declaration of Contamination

The service, repair, and/or disposal of vacuum equipment and components will only be carried out if a correctly completed declaration has been submitted. Non-completion will result in delay. This declaration may only be completed (in block letters) and signed by authorized and qualified staff.

- Description of product**
Type _____
Part number _____
Serial number _____
- Reason for return**

- Operating fluid(s) used**
(Must be drained before shipping.)

- Used in copper process**
no yes → Seal product in plastic bag and mark it with a corresponding label.
- Process related contamination of product:**

toxic	no <input type="checkbox"/> 1)	yes <input type="checkbox"/>	
corrosive	no <input type="checkbox"/> 1)	yes <input type="checkbox"/>	
biological hazard	no <input type="checkbox"/>	yes <input type="checkbox"/> 2)	
explosive	no <input type="checkbox"/>	yes <input type="checkbox"/> 2)	
radioactive	no <input type="checkbox"/>	yes <input type="checkbox"/> 2)	
other harmful substances	no <input type="checkbox"/> 1)	yes <input type="checkbox"/>	

1) or not containing any amount of hazardous residues that exceed the permissible exposure limits
2) Products thus contaminated will not be accepted without written evidence of decontamination.

The product is free of any substances which are damaging to health. yes
- Harmful substances, gases and/or by-products**
Please list all substances, gases, and by-products which the product may have come into contact with:

Trade/product name manufacturer	Chemical name (or symbol)

Precautions associated with substance	Action if human contact
- Legally binding declaration:**
We hereby declare that the information on this form is complete and accurate and that we will assume any further costs that may arise. The contaminated product will be dispatched in accordance with the applicable regulations.
Organization/company _____
Address _____
Post code, place _____
Phone _____ Fax _____
Email _____
Name _____
Company stamp _____

This form can be downloaded from our website.
Copies: Original for addressee
1 copy for accompanying documents
1 copy for file of sender

Manufacturer's Declaration

as defined by the Directive relating to machinery 98/37/EC, Appendix IIb

We, INFICON, hereby declare that putting the incomplete equipment mentioned below into operation is not permitted until evidence is given that the system into which that incomplete equipment shall be installed is in accordance with the provisions of the EC Directive relating to machinery.

We also declare that the equipment mentioned below complies with the provisions of the Directive relating to electrical equipment designed for use within certain voltage limits 73/23/EEC and the Directive relating to electromagnetic compatibility 89/336/EEC.

Inline Valve

pneumatically actuated bellows sealed with position indicator and pilot valve normally open

VIP016 ... 040-X

Part numbers

250-316 250-336 250-356

Standards

Harmonized and international/national standards and specifications:

- EN 292-2
- DIN EN 60 204-1
- ISO 9803
- ISO 1609
- ISO 4414
- DIN 28 403
- DIN 28 404
- DIN 2501-1
- DIN 24 558

Signatures

INFICON AG, Balzers

31 October 2002

31 October 2002

Remo Klaiber

G. Sebe

Remo Klaiber
Product Marketing
Management

Dr. Georg Sebe
Technical Support Manager
Quality Representative



LI-9496 Balzers
Liechtenstein
Tel +423 / 388 3111
Fax +423 / 388 3700
reach.liechtenstein@inficon.com
www.inficon.com