

### Inline Valve

manually actuated  
bellows sealed  
with step drive

VIH016-040-X

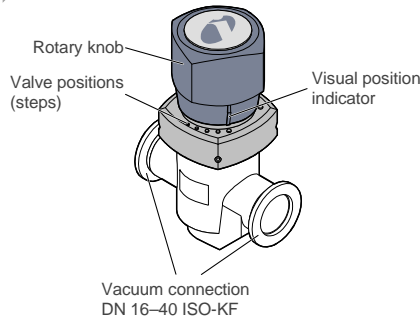
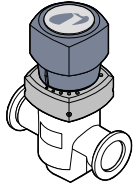

#### Valve positions (steps)

The valve is manually opened or closed with 3/8 turns of the rotary knob. The four intermediate valve positions (steps) are used for dosing gas flows.

The visual position indicator shows the current valve position.

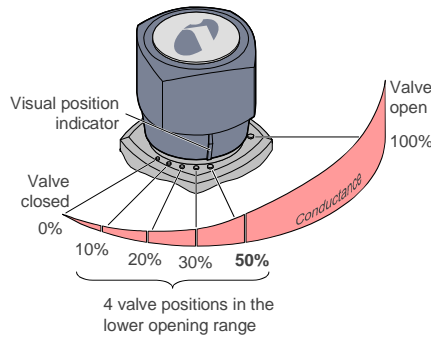

Instruction sheet  
Incl. Manufacturer's Declaration

sima54e1-a (0104)

### Product Identification

In all communications with Inficon, please specify the information on the product nameplate. For convenient reference copy that information into the nameplate replica below.

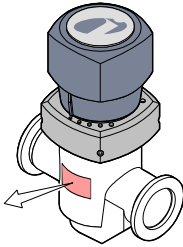

INFICON, LI - 9496 Balzers  
Typ: \_\_\_\_\_  
No: \_\_\_\_\_  
F-No: \_\_\_\_\_

### Validity

This document applies to products with the following part numbers:

250-365 (DN 16 ISO-KF)  
250-375 (DN 25 ISO-KF)  
250-385 (DN 40 ISO-KF)

The part number can be taken from the product nameplate.

If not indicated otherwise in the legends, the illustrations in this document correspond to the valve with the nominal diameter DN 25 ISO-KF. They apply to valves with other nominal diameters by analogy.

We reserve the right to make technical changes without prior notice.

### Intended Use

The inline valves are used as shut-off, dosing, and venting devices in vacuum applications.

### Liability and Warranty

Inficon assumes no liability and the warranty becomes null and void if end-user or third parties

- disregard the information in this document
- use the product in a non-conforming manner
- make any kind of interventions (modifications, alterations etc.) to the product
- use the product with accessories and options not listed in the corresponding product documentation.

The end-user assumes the responsibility in conjunction with the process media used.

### Technical Data

Connection flange	DN 16 ISO-KF	DN 25 ISO-KF	DN 40 ISO-KF
Actuation	manual with 6 valve positions (steps)		
Stroke of the valve plate	5.5 mm	10 mm	12 mm
Conductance <sup>1)</sup>	2.5 l/s	8 l/s	20 l/s
Valve positions	1 Valve closed 2 10% 3 20% 4 30% 5 50% 6 100% (valve open)		
Service life <sup>2)</sup>	10,000 cycles		
Tightness	1×10 <sup>-9</sup> mbar l/s		
Pressure range	1×10 <sup>-8</sup> mbar ... 6 bar (absolute)		
Pressure difference Δp in closing direction	2 bar		
Pressure difference Δp in opening direction	2 bar	1.5 bar	
Opens to a pressure difference Δp	2 bar	3 bar	4 bar
Temperatures	0 °C ... 50 °C		
ambiance			
bakeout			
housing	150 °C		
actuator	50 °C		
Installation angle	any; ensure swift access		
Flow direction	any; preferably in closing direction		
Materials	housing 1.4301 bellows / valve plate 1.4541 / 1.4301 pressure spring DN 16 + 25 1.4301 DN 40 1.1200 seals FPM actuator PBT with glass fiber rotary knob PBT with glass fiber protective lids PE packing material carton box, PE, PU		
Weight			
housing	0.48 kg	0.7 kg	1.4 kg

<sup>1)</sup> For air with molecular flow

<sup>2)</sup> Cycles without expendable parts (seals) and under clean operating conditions

### Safety

#### Symbols Used

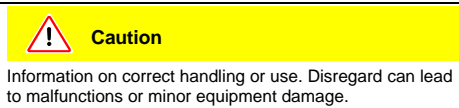
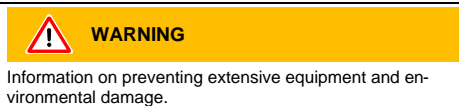
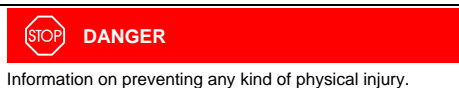

Dimensions in mm

### General Safety Instructions

- Adhere to the applicable regulations and take the necessary precautions for the process media used.  
Consider possible reactions between the materials and the process media.
- Adhere to the applicable regulations and take the necessary precautions for all work you are going to do and consider the safety instructions in this document.
- Before beginning to work, find out whether any vacuum components are contaminated. Adhere to the relevant regulations and take the necessary precautions when handling contaminated parts.

Communicate the safety instructions to all other users.

## Dimensions

### DN 16 ISO-KF

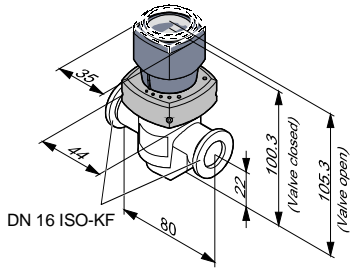

### DN 25 ISO-KF

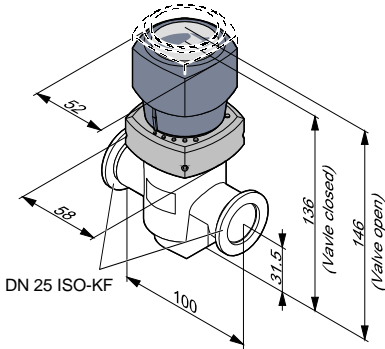

### DN 40 ISO-KF

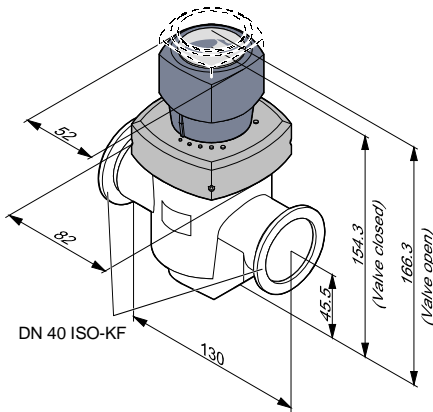

## Installation

### Vacuum Connection

#### Skilled personnel



The vacuum connection may only be established by persons who have suitable technical training and the necessary experience or who have been instructed by the end-user of the product.

#### DANGER



Caution: overpressure in the vacuum system >1 bar

Injury caused by released parts and harm caused by escaping process gases can result if clamps are opened while the vacuum system is pressurized.

Do not open any clamps while the vacuum system is pressurized. Use the type clamps which are suited to overpressure.

#### DANGER



Caution: movement of the valve plate  
When the valve is in operation, the valve plate can catch parts of the body and thus cause injuries.

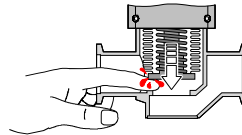

Take appropriate measures (e.g. protective grid) to prevent access to the inside of the installed valve.

#### Caution



Caution: dirt sensitive area  
Touching the product or parts thereof with one's bare hands increases the desorption rate.  
Always wear clean, lint-free gloves and use clean tools when working in this area.

#### Caution



Caution: vacuum component  
Dirt and damages impair the function of the vacuum component.  
When handling vacuum components, take appropriate measures to ensure cleanliness and prevent damages.

#### Caution



Keep the protective lids and put them in place again when removing the product from the vacuum system.

Remove the protective lids and install the valve to the vacuum system by means of the small flange fittings.  
Any installation angle and flow direction may be chosen.

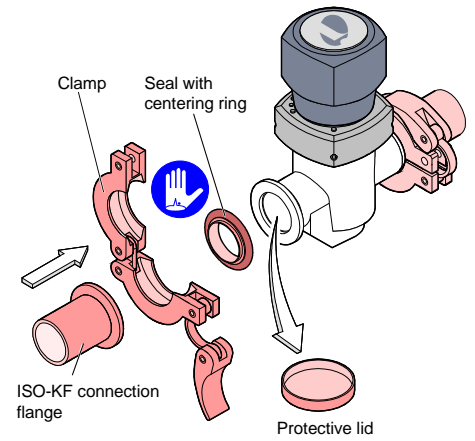

ISO-KF connection flange

Protective lid



81 865 4 01 - 8

(0104)

## Operation

The product is ready for operation as soon as it has been installed.

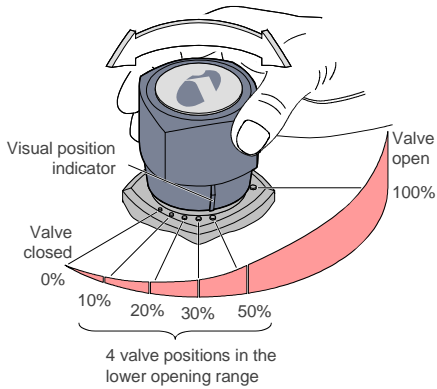

**Pressure range:**  $1 \times 10^{-8}$  mbar ... 6 bar (absolute)

**Pressure difference  $\Delta p$  in closing direction**

**Caution**

Caution: pressure difference  $\Delta p$

AT  $\Delta p > 2$  bar the seal of the valve plate can get damaged.  
Avoid pressure differences  $\Delta p > 2$  bar.

**Pressure difference  $\Delta p$  in opening direction**

**Caution**

Caution: pressure difference  $\Delta p$

At  $\Delta p > 2$  bar DN 16+25 ISO-KF  
 $\Delta p > 1.5$  bar DN 40 ISO-KF  
the valve is opened.  
Avoid pressure differences  
 $\Delta p > 2$  bar DN 16+25 ISO-KF  
 $\Delta p > 1.5$  bar DN 40 ISO-KF

**Opening against a pressure difference  $\Delta p$**

**Caution**

Caution: pressure difference  $\Delta p$

If actuated at  $\Delta p > 2$  bar DN 16 ISO-KF  
 $\Delta p > 3$  bar DN 25 ISO-KF  
 $\Delta p > 4$  bar DN 40 ISO-KF  
the valve can get damaged.  
Avoid pressure differences  
 $\Delta p > 2$  bar DN 16 ISO-KF  
 $\Delta p > 3$  bar DN 25 ISO-KF  
 $\Delta p > 4$  bar DN 40 ISO-KF.

## Deinstallation

### Vacuum Connection

**Skilled personnel**

The vacuum connection may only be disassembled by persons who have suitable technical training and the necessary experience or who have been instructed by the end-user of the product.

**DANGER**

Caution: contaminated parts  
Contaminated parts can be detrimental to health and environment.  
Before beginning to work, find out whether any parts are contaminated. Adhere to the relevant regulations and take the necessary precautions when handling contaminated parts.

**Note**

Caution: vacuum component  
Dirt and damages impair the function of the vacuum component.  
When handling vacuum components, take appropriate measures to ensure cleanliness and prevent damages.

**Caution**

Caution: dirt sensitive area  
Touching the product or parts thereof with one's bare hands increases the desorption rate.  
Always wear clean, lint-free gloves and use clean tools when working in this area.

Vent the vacuum system and disassemble the small flange connection. Place the protective lids.

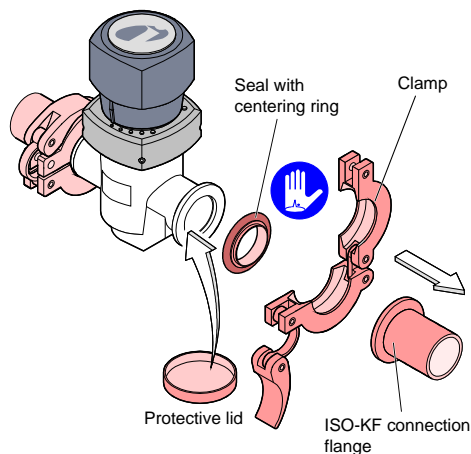

## Further Information

Refer to the Operating manual with regard to maintenance, repair, and spare parts.

The Operating manual sina54e1 can

- be downloaded from our website or
- or ordered at Inficon.

## Returning the Product

**WARNING**

Caution: forwarding contaminated products  
Contaminated products (e.g. radioactive, toxic, caustic or microbiological hazard) can be detrimental to health and environment.  
Products returned to Inficon should preferably be free of harmful substances. Adhere to the forwarding regulations of all involved countries and forwarding companies and enclose a duly completed declaration of contamination.

Products that are not clearly declared as "free of harmful substances" are decontaminated at the expense of the customer.

Products not accompanied by a duly completed declaration of contamination are returned to the sender at his own expense.

## Disposal

**DANGER**

Caution: contaminated parts  
Contaminated parts can be detrimental to health and environment.  
Before beginning to work, find out whether any parts are contaminated. Adhere to the relevant regulations and take the necessary precautions when handling contaminated parts.

### Separating the components

After disassembling the product, separate its components according to the following criteria:

- Contaminated components  
Contaminated components (radioactive, toxic, caustic, or biological hazard etc.) must be decontaminated in accordance with the relevant national regulations, separated according to their materials, and disposed of.
- Other components  
Such components must be separated according to their materials and recycled.

## Declaration of Contamination

The service, repair, and/or disposal of vacuum equipment and components will only be carried out if a correctly completed declaration has been submitted. Non-completion will result in delay. This declaration may only be completed (in block letters) and signed by authorized and qualified staff.

**1 Description of product**  
 Type \_\_\_\_\_  
 Article No. \_\_\_\_\_  
 Serial No. \_\_\_\_\_

**2 Reason for return**  
 \_\_\_\_\_  
 \_\_\_\_\_

**3 Operating fluid(s) used**  
 \_\_\_\_\_

**4 Process related contamination of product:**

toxic	no <input type="checkbox"/>	yes <input type="checkbox"/>
corrosive	no <input type="checkbox"/>	yes <input type="checkbox"/>
biological hazard	no <input type="checkbox"/>	yes <input type="checkbox"/> *)
explosive	no <input type="checkbox"/>	yes <input type="checkbox"/> *)
radioactive	no <input type="checkbox"/>	yes <input type="checkbox"/> *)
other harmful substances	no <input type="checkbox"/>	yes <input type="checkbox"/>

\*) Products thus contaminated will not be accepted without written evidence of decontamination!

The product is free of any substances which are damaging to health

**5 Harmful substances, gases and/or by-products**  
 Please list all substances, gases, and by-products which the product may have come into contact with:

Trade/product name manufacturer	Chemical name (or symbol)

Dangerous material class	Measures in case of spillage	First aid in case of contact

**6 Legally binding declaration:**  
 I/we hereby declare that the information on this form is complete and accurate and that I/we will assume any further costs that may arise. The contaminated product will be dispatched in accordance with the applicable regulations.

Organization/company \_\_\_\_\_  
 Address \_\_\_\_\_  
 Post code, place \_\_\_\_\_  
 Phone \_\_\_\_\_ Fax \_\_\_\_\_  
 Email \_\_\_\_\_  
 Name \_\_\_\_\_

Company stamp \_\_\_\_\_

Date and legally binding signature \_\_\_\_\_

## Manufacturer's Declaration

as defined by the Directive relating to machinery 98/37/EEC, Appendix IIb

We, Inficon, hereby declare that putting the incomplete equipment mentioned below into operation is not permitted until evidence is given that the system into which the incomplete equipment is to be installed is in accordance with the provisions of the Directive relating to machinery.

### Inline Valve

manually actuated  
 bellows sealed  
 with step drive  
 VIH016-040-X

#### Part numbers

250-365  
 250-375  
 250-385

#### Standards

Harmonized and international/national standards and specifications:

- EN 292
- EN 294
- ISO 9803
- ISO 1609
- ISO 2861-1
- DIN 28 403

#### Signatures

Inficon AG, Liechtenstein

4 April 2001



Hans-Christoph Gehlhar  
 Product management  
 Components and valves

4 April 2001

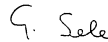

Dr. Georg Sele  
 Technical Support Manager  
 Quality Representative



Postfach 1000  
 LI-9496 Balzers  
 Liechtenstein  
 Tel +423 / 388 3111  
 Fax +423 / 388 3700  
 reachfl@inficon.com  
 www.inficon.com

This form can be downloaded from our website.

Copies: Original for addressee  
 1 copy for accompanying documents  
 1 copy for file of sender