

Description

The angle valve has two operating modes:

- REMOTE mode
Drive via control voltage 15 ... 30 VDC.
- LOCAL mode
Drive via supply voltage 85 ... 248 VAC.

The operating mode is selected by setting a switch (see Installation/Electrical connection).

REMOTE mode

In the REMOTE mode, the supply voltage of 85 ... 248 VAC is constantly fed. The angle valve is opened and closed via the control contact (0 VDC).

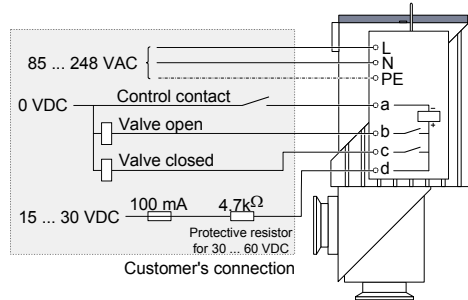

LOCAL mode

The angle valve is opened and closed directly via the supply voltage.

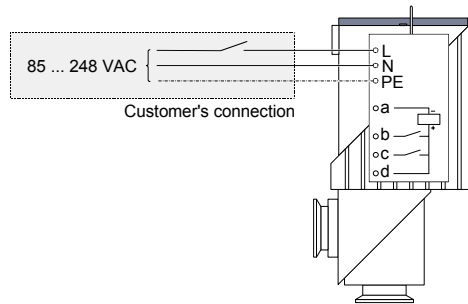

Indication of positions and faults

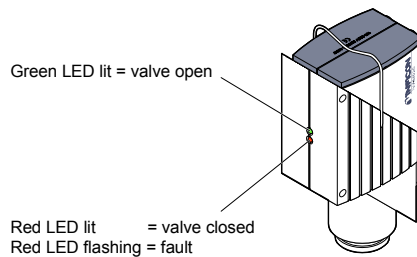

Position indicator (in REMOTE mode only)

The integrated position indicator allows for polling the valve positions. In the event of a fault, the signal "valve closed" is constantly fed.

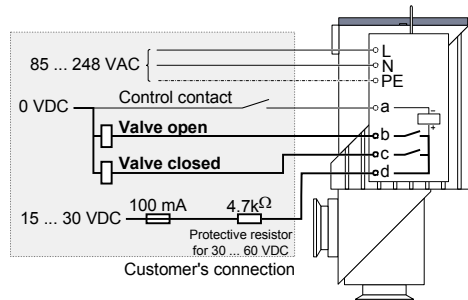

Safety

Symbols Used

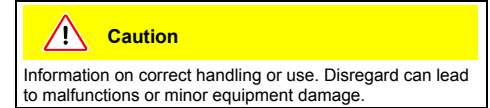
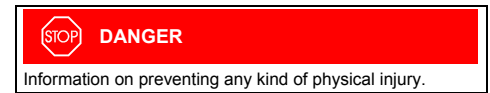

20 Dimensions in mm

General Safety Instructions

- Adhere to the applicable regulations and take the necessary precautions for the process media used. Consider possible reactions of the process media due to the heat generated by the product.
- Adhere to the applicable regulations and take the necessary precautions for all work you are going to do and consider the safety instructions in this document.
- Before beginning to work, find out whether any vacuum components are contaminated. Adhere to the relevant regulations and take the necessary precautions when handling contaminated parts.

Communicate the safety instructions to all other users.

Liability and Warranty

INFICON assumes no liability and the warranty becomes null and void if end-users or third parties

- disregard the information in this document
- use the product in a non-conforming manner
- make any kind of changes (modifications, alterations etc.) to the product
- use the product with accessories and options not listed in the corresponding product documentation.

The end-user assumes the responsibility in conjunction with the process media used.

Technical Data

Connection flange	DN 16 ISO-KF	DN 25 ISO-KF	DN 40 ISO-KF
Actuation	opening: electromagnetically closing: by pressure spring		
Supply voltage	85 ... 248 VAC		
Frequency	50 / 60 Hz		
Power consumption	400 W (max. upon switching on)		
Pickup-/Holding power	405/8.1W	415/8.3W	367/7.5W
Control voltage	15 ... 30 VDC ¹⁾		
Power consumption	3 ... 5 mA		
Position indicator switching voltage ²⁾ switching current ³⁾	15 ... 30 VDC 100 mA		
Type of protection Protection class	IP 54 according to DIN 40 050 II		
Cable diameter feeder line control cable	5 ... 7 mm 5 ... 7 mm		
Installation angle Flow direction	any any		
Cycle life ⁴⁾	2 million		
Switching frequency at 40 °C ⁵⁾ at 50 °C ⁵⁾	30 / min 20 / min		

Angle Valve

electromagnetically actuated
with automatic voltage
adaptation 85 ... 248 VAC

VAM016 ... 040 A/X

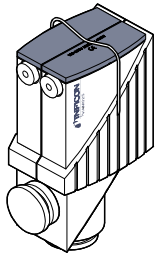

Instruction Sheet
incl. Manufacturer's Declaration

sima34e1-a (0209)

Product Identification

In all communications with INFICON, please specify the information given on the product nameplate. For convenient reference copy that information into the nameplate replica below.

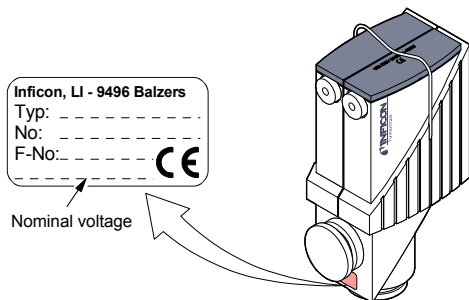

Validity

This document applies to products with the following part numbers:

Aluminum housing with FPM seals	Stainless steel housing with FPM seals	Nominal diameter
250-661	250-666	DN 16 ISO-KF
250-671	250-676	DN 25 ISO-KF
250-681	250-686	DN 40 ISO-KF

The part number (No) can be taken from the product nameplate.

If not indicated otherwise in the legends, the illustrations in this document correspond to the valve with the nominal diameter DN 25 ISO-KF. They apply to valves with other nominal diameters by analogy.

We reserve the right to make technical changes without prior notice.

Intended Use

The electromagnetically actuated bellows sealed angle valves are used as shut-off or venting devices in vacuum applications.

Functional Principle

The angle valves are opened electromagnetically and closed by means of a prestressed pressure spring. They close, or remain closed, on power loss.

Connection flange	DN 16 ISO-KF	DN 25 ISO-KF	DN 40 ISO-KF
Opening time	100 ms	120 ms	230 ms
Closing time	240 ms	240 ms	700 ms
Dead time ⁶⁾	50 ms	170 ms	500 ms
Pressure range	1×10 ⁻⁸ mbar ... 1.3 bar (absolute)		
Bursting pressure	3 bar (overpressure)		
Pressure difference Δp in closing direction	1.3 bar		
in opening direction	1.3 bar		
Opens to a pressure difference Δp	1.3 bar		
Ambient temperature	0 ... 50 °C		
Tightness	1×10 ⁻⁹ mbar l/s		
Conductance ⁷⁾	4 l/s	16 l/s	40 l/s
Materials housing	aluminum (3.2374) or stainless steel (1.4301)		
inside section seals	1.4301 and 1.4541 FPM		
shell	PAGV 30		

Weight aluminum housing	1.3 kg	2.2 kg	4 kg
stainless steel housing	1.5 kg	2.9 kg	5.4 kg

¹⁾ 30 ... 60 VDC with serial resistor (4.7 k Ω)

²⁾ Corresponds to the control voltage

³⁾ Must be protected with a quick-acting 100 mA fuse provided by the end-user

⁴⁾ Cycles without expendable parts (seals) and under clean operating conditions

⁵⁾ Ambient temperature

⁶⁾

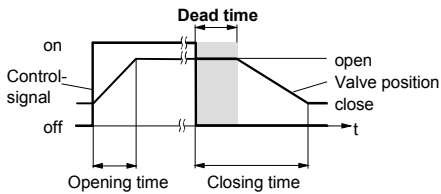

⁷⁾ For air with molecular flow

Dimensions in mm

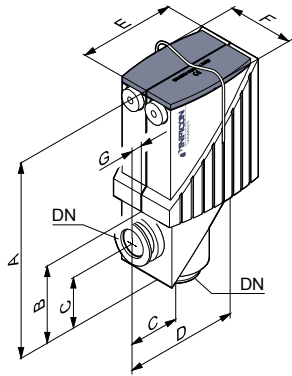

DN	A	B	C	D	E	F	G
DN 16 ISO-KF	160	58	40	96	84.5	59	7.5
DN 25 ISO-KF	194	76	50	111	96.5	75	10
DN 40 ISO-KF	230	98	65	138	119.5	96	13.5

Installation

Vacuum Connection

Skilled personnel

The vacuum connection may only be established by persons who have suitable technical training and the necessary experience or who have been instructed by the end-user of the product.

DANGER

Caution: overpressure in the vacuum system >1 bar

Injury caused by released parts and harm caused by escaping process gases can result if clamps are opened while the vacuum system is pressurized.

Do not open any clamps while the vacuum system is pressurized. Use the type clamps which are suited to overpressure.

Caution

Caution: vacuum component

Dirt and damages impair the function of the vacuum component.

When handling vacuum components, take appropriate measures to ensure cleanliness and prevent damages.

Caution

Caution: dirt sensitive area

Touching the product or parts thereof with one's bare hands increases the desorption rate. Always wear clean, lint-free gloves and use clean tools when working in this area.

Keep the protective lids.

Remove the protective lids and install the valve to the vacuum system by means of the small flange fittings. Any installation angle and flow direction may be chosen.

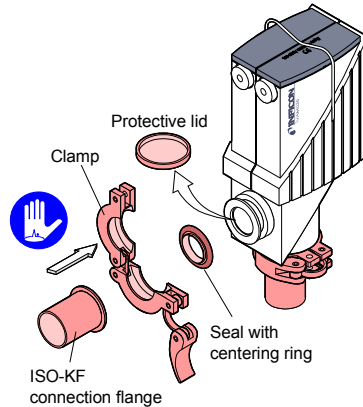

Electrical Connection

Skilled personnel

The electrical connection, in accordance with the VDE 0100 guidelines, may be made only by a licensed electrician, qualified as per VDE 0105. The line cables shall be isolated from the line supply during all electrical work.

DANGER

Caution: mains voltage

Products that are not professionally connected to ground can be hazardous in the event of a malfunction.

Connect the product according to the local regulations and ground it correctly.

Caution

Caution: electrostatic fields

If the valve is installed in the vicinity of switched or electronically controlled heavy electric loads, such as furnaces, heaters, motors or RF generators, disturbances may occur.

Install a mains filter in the supply line of the valve.

Caution

Caution: high voltage tests

The valve is factory tested according to the DIN EN 60 204 standard. Additional high voltage tests may destroy the valve.

Do not carry out any further high voltage tests.

1 Remove the clamp.

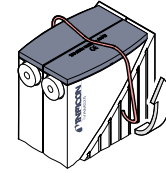

2 Remove the cover.

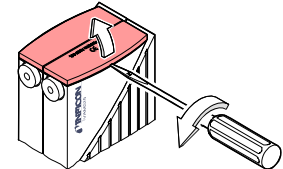

3 Set the operating mode selection switch.

The operating mode must be selected before the electrical connection is established. If a 15 ... 30 VDC control voltage is available, choose REMOTE.

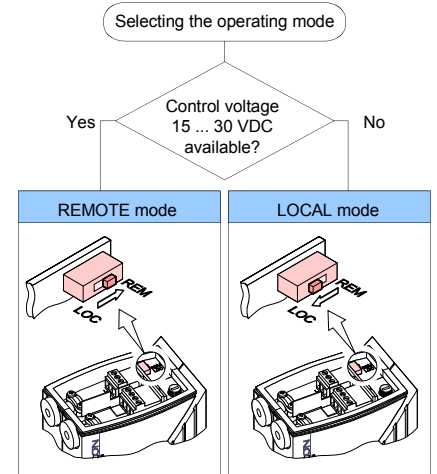

4 Prepare the feeder line.

Caution

The cable must meet the following specifications:

- flexible
- conductor cross-section 1 mm²
- 3 poles with protective conductor (P+N+PE)
- 5 ... 7 mm diameter (for the cable feedthrough to meet the IP 54 specifications)

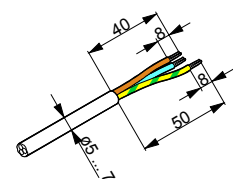

(0209)

5 Connect the feeder line.

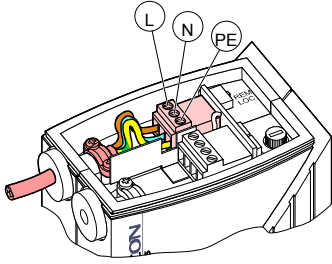

6 Prepare the control cable (for REMOTE mode only).

Caution



The cable must meet the following specifications:

- flexible, 4 poles
- conductor cross-section 0.75 mm^2
- 5 ... 7 mm diameter (for the cable feedthrough to meet the IP 54 specifications)

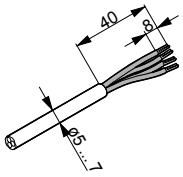

7 Connect the control cable.

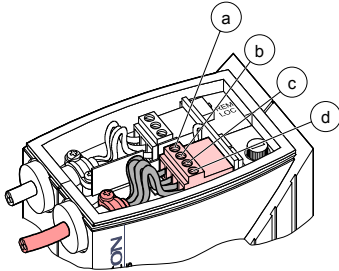
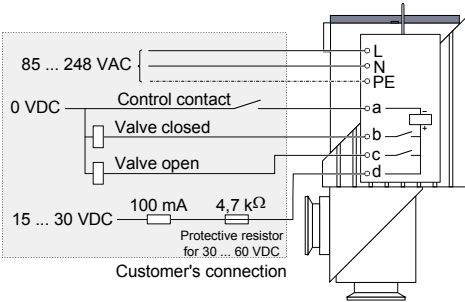

8 Mount the cover.

Caution



Be careful not to squeeze any cable leads.

9 Mount the clamp again.

Operation

The product is ready for operation as soon as it has been installed.

DANGER



Caution: bursting pressure

Overpressures $>3 \text{ bar}$ (e.g. in the event of an explosion) can cause the inside section and housing to burst. This could result in injuries caused by catapulted parts and health damages due to leaking process gases.

Protect the entire vacuum system against overpressures $>3 \text{ bar}$.

Signaling behavior

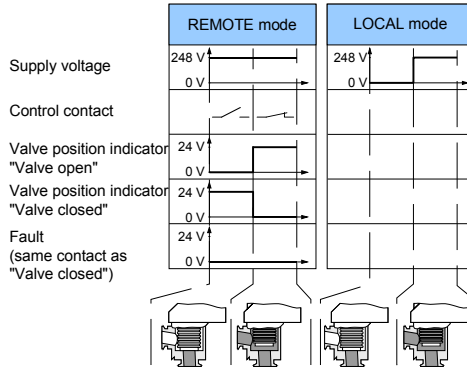

Indication of positions and faults

	REMOTE mode	LOCAL mode
Valve closed	red LED lit	both LEDs dark
Valve opening	both LEDs dark	red LED lights up briefly
Valve open	green LED lit	green LED lit
Fault	red LED flashing	red LED flashing

Pressure range: $1 \times 10^{-8} \text{ mbar} \dots 1.3 \text{ bar}$ (absolute)

Pressure difference Δp in closing direction

Caution



Caution: pressure difference Δp

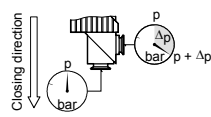

At $\Delta p > 1.3 \text{ bar}$ the valve may no longer be tight. Avoid pressure differences $\Delta p > 1.3 \text{ bar}$.

Pressure difference Δp in opening direction

Caution



Caution: pressure difference Δp

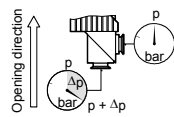

At $\Delta p > 1.3 \text{ bar}$ the valve is opened. Avoid pressure differences $\Delta p > 1.3 \text{ bar}$.

Opening against a pressure difference Δp

Caution



Caution: pressure difference Δp

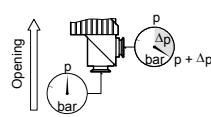

At $\Delta p > 1.3 \text{ bar}$ the valve cannot open. Avoid pressure differences $\Delta p > 1.3 \text{ bar}$.

Deinstallation

Electrical Connection

Skilled personnel



The electrical connection, in accordance with the VDE 0100 guidelines, may be made only by a licensed electrician, qualified as per VDE 0105. The line cables shall be isolated from the line supply during all electrical work.

DANGER



Caution: mains voltage

Touching live parts is hazardous.

Switch all mains and control voltage sources off and secure them against inadvertent power-on before performing any electrical work on the product.

1 Remove the clamp.

2 Remove the cover.

3 Disconnect the feeder line.

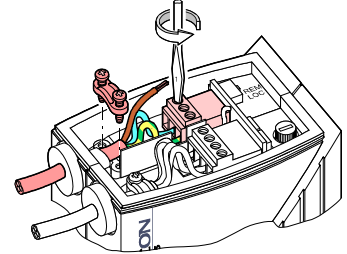

4 Disconnect the control cable (for REMOTE mode only).

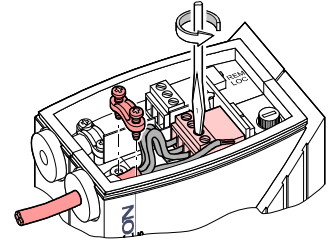

5 Mount the cover.

6 Mount the clamp again.

Vacuum Connection

Skilled personnel



The vacuum connection may only be disassembled by persons who have suitable technical training and the necessary experience or who have been instructed by the end-user of the product.

DANGER



Caution: contaminated parts

Contaminated parts can be detrimental to health and environment.

Before beginning to work, find out whether any parts are contaminated. Adhere to the relevant regulations and take the necessary precautions when handling contaminated parts.

Caution



Caution: dirt sensitive area

Touching the product or parts thereof with one's bare hands increases the desorption rate.

Always wear clean, lint-free gloves and use clean tools when working in this area.

Caution

Caution: vacuum component
Dirt and damages impair the function of the vacuum component.
When handling vacuum components, take appropriate measures to ensure cleanliness and prevent damages.

Vent the vacuum system and disassemble the small flange connection. Place the protective lids.

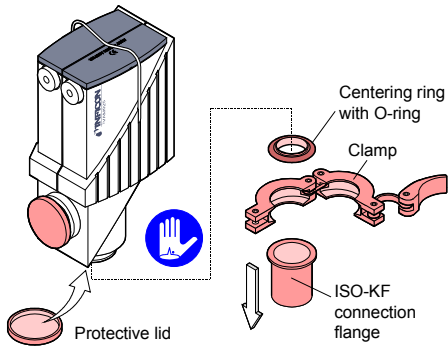

Further Information

Refer to the Operating manual with regard to maintenance, repair, and spare parts.

The Operating Manual sina34e1 can be

- downloaded from our website or
- ordered at INFICON.

Returning the Product

WARNING

Caution: forwarding contaminated products
Contaminated products (e.g. radioactive, toxic, caustic or microbiological hazard) can be detrimental to health and environment.
Products returned to INFICON should preferably be free of harmful substances. Adhere to the forwarding regulations of all involved countries and forwarding companies and enclose a duly completed declaration of contamination.

Products that are not clearly declared as "free of harmful substances" are decontaminated at the expense of the customer. Products not accompanied by a duly completed declaration of contamination are returned to the sender at his own expense.

Disposal

DANGER

Caution: contaminated parts
Contaminated parts can be detrimental to health and environment.
Before beginning to work, find out whether any parts are contaminated. Adhere to the relevant regulations and take the necessary precautions when handling contaminated parts.

Separating the components

After disassembling the product, separate its components according to the following criteria:

- Contaminated components
Contaminated components (radioactive, toxic, caustic, or biological hazard etc.) must be decontaminated in accordance with the relevant national regulations, separated according to their materials, and disposed of.
- Other components
Such components must be separated according to their materials and recycled.

Declaration of Contamination

The service, repair, and/or disposal of vacuum equipment and components will only be carried out if a correctly completed declaration has been submitted. Non-completion will result in delay. This declaration may only be completed (in block letters) and signed by authorized and qualified staff.

- Description of product**
Type _____
Part number _____
Serial number _____
- Reason for return**

- Operating fluid(s) used**
(Must be drained before shipping.)

- Process related contamination of product:**

toxic	no <input type="checkbox"/> 1)	yes <input type="checkbox"/>	
corrosive	no <input type="checkbox"/> 1)	yes <input type="checkbox"/>	
biological hazard	no <input type="checkbox"/>	yes <input type="checkbox"/> 2)	
explosive	no <input type="checkbox"/>	yes <input type="checkbox"/> 2)	
radioactive	no <input type="checkbox"/>	yes <input type="checkbox"/> 2)	
other harmful substances	no <input type="checkbox"/> 1)	yes <input type="checkbox"/>	

1) or not containing any amount of hazardous residues that exceed the permissible exposure limits

2) Products thus contaminated will not be accepted without written evidence of decontamination!

The product is free of any substances which are damaging to health
- Harmful substances, gases and/or by-products**
Please list all substances, gases, and by-products which the product may have come into contact with:

Trade/product name manufacturer	Chemical name (or symbol)

Precautions associated with substance	Action if human contact

- Legally binding declaration:**
I/we hereby declare that the information on this form is complete and accurate and that I/we will assume any further costs that may arise. The contaminated product will be dispatched in accordance with the applicable regulations.

Organization/company _____
Address _____
Post code, place _____
Phone _____ Fax _____
Email _____
Name _____

Company stamp _____

Date and legally binding signature _____

This form can be downloaded from our website.
Copies: Original for addressee
1 copy for accompanying documents
1 copy for file of sender

Manufacturer's Declaration

as defined by the Directive relating to machinery 98/37/EC, Appendix IIb

We, INFICON, hereby declare that putting the incomplete equipment mentioned below into operation is not permitted until evidence is given that the system into which that incomplete equipment shall be installed is in accordance with the provisions of the EC Directive relating to machinery.

We also declare that the products mentioned below comply with the provisions of the Directive relating to electrical equipment designed for use within certain voltage limits 73/23/EEC and the Directive relating to electromagnetic compatibility 89/336/EEC and the Directive relating to electromagnetic compatibility 89/336/EEC.

Angle Valve

electromagnetically actuated
with automatic voltage
adaptation 85 ... 248 VAC

VAM016 ... 040 A/X

Part numbers

250-661 250-666
250-671 250-676
250-681 250-686

Standards

Harmonized and international/national standards and specifications:

- EN 292-1 and EN 292-2
- EN 60 204-1
- VDE 0884
- EN 55022
- EN 50082-2
- EN 50081-2
- ISO 9803
- ISO 1609
- DIN 28 403
- DIN 2501
- ISO 2861/1

Signatures

INFICON AG, Liechtenstein

Balzers, 30 March 2001

Balzers, 30 March 2001

Hans-Christoph Gehlhar
Product management
Components and valves

Dr. Georg Sele
Technical Support Manager
Quality Representative



LI-9496 Balzers
Liechtenstein
Tel +423 / 388 3111
Fax +423 / 388 3700
reach.liechtenstein@inficon.com
www.inficon.com