

Insert Valve

pneumatically operated
bellows sealed

VAP005-Z

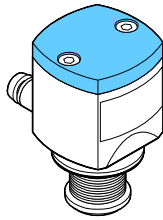

Instruction Sheet
Incl. Manufacturer's Declaration

sima27e1 (0204)

Product Identification

In all communications with INFICON, please specify the information on the product nameplate. For convenient reference copy that information into the space provided below.

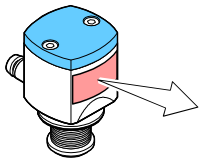

INFICON AG, LI-9496 Balzers
 Model: _____
 PN: _____
 SN: _____

Validity

This document applies to products with part number 250-045. The part number (PN) can be taken from the product nameplate.

We reserve the right to make technical changes without prior notice.

If not indicated otherwise in the illustrations, the dimensions are in mm.

Intended Use

The VAP005-Z is used as shut-off valve in vacuum systems.

Functional Principle

The VAP005-Z is opened pneumatically and closed by the prestressed pressure spring.

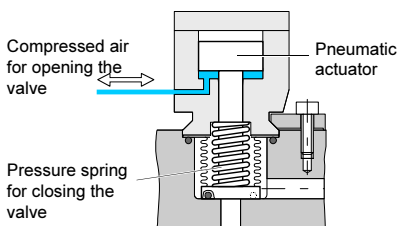

It closes automatically in the event of a compressed air failure.

Safety

Symbols Used

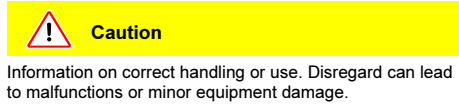
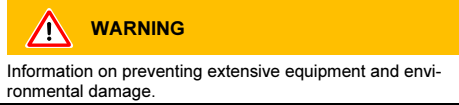

Personnel Qualifications

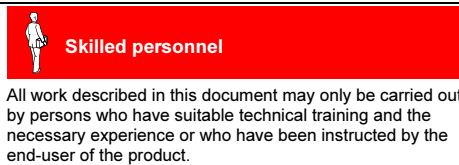

General Safety Instructions

- Adhere to the applicable regulations and take the necessary precautions for the process media used. Consider possible reactions between the materials (→ "Technical Data") and the process media.
- Adhere to the applicable regulations and take the necessary precautions for all work you are going to do and consider the safety instructions in this document.
- Before beginning to work, find out whether any vacuum components are contaminated. Adhere to the relevant regulations and take the necessary precautions when handling contaminated parts.

Communicate the safety instructions to all other users.

Liability and Warranty

INFICON assumes no liability and the warranty becomes null and void if the end-user or third parties

- disregard the information in this document
- use the product in a non-conforming manner
- make any kind of interventions (modifications, alterations etc.) on the product
- use the product with accessories not listed in the corresponding product documentation.

The end-user assumes the responsibility in conjunction with the process media used.

Technical Data

Nominal diameter	ø5 mm
Vacuum connection	with 3 claw grips
Conductance for air	
molecular flow	0.4 l/s ¹⁾
laminar flow	4 l/s ¹⁾
Mounting orientation	any
Switching frequency max.	150 / min ²⁾
Cycles to first overhaul	≈1,500,000 ³⁾
Tightness	1×10 ⁻⁹ mbar l/s
Pressure range	1×10 ⁻⁸ mbar ... 4 bar (absolute)
Pressure difference Δp	
In closing direction	3 bar
In opening direction	3 bar
Opens to a pressure difference Δp of	3 bar (Compressed air: overpressure 4 bar)
Closing time	35 ms
Opening time	35 ms
	Δp = 0 bar, (Compressed air: overpressure 6 bar)
Compressed air	
Connection	instant push-in fitting ø4 mm
Pressure range	4 ... 8 bar overpressure
Volume	0.24 cm ³
Temperatures	
Ambiance	5 ⁴⁾ ... 80 °C
Bakeout	150 °C (actuator 80 °C)
Materials	
Bellows	stainless steel 1.4301
Actuator	anodized aluminum
Seals	FPM
Weight	0.1 kg

- ¹⁾ Depending on customer's connection.
- ²⁾ With pressure difference Δp = 0 bar.
- ³⁾ Under clean operating conditions.
- ⁴⁾ -15 °C, if the ambiance is free of condensable gases.

Dimensions [mm]

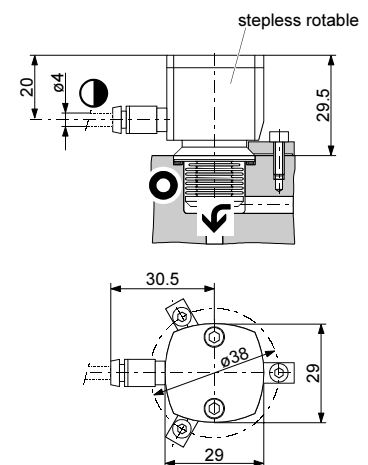

- Flow direction
- Compressed air connection
- Protective lid

Installation

Vacuum Connection

Caution

Caution: vacuum component
Dirt and damages impair the function of the vacuum component.
When handling vacuum components, take appropriate measures to ensure cleanliness and prevent damages.

Caution

Caution: dirt sensitive area
Touching the product or parts thereof with bare hands increases the desorption rate.
Always wear clean, lint-free gloves and use clean tools when working in this area.

Fit the VAP005-Z into the valve seat, which has to be prepared as indicated below.

Space required

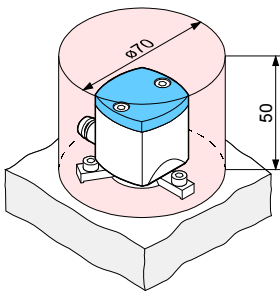

Preparing the valve seat

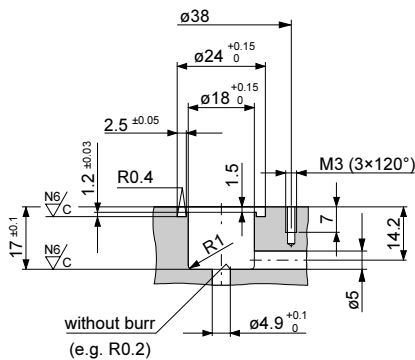

Machining sign:
centrically machined and
roughness value $\leq 0.8 \mu\text{m}$ (N6)

Cleaning the valve seat

DANGER

Caution: cleaning agents
Cleaning agents can be detrimental to health and environment.
Adhere to the relevant regulations and take the necessary precautions when handling and disposing of cleaning agents. Consider possible reactions with the product materials (→ "Technical Data").

- Clean the valve seat with a grease solving, non-scouring cleaner.
- After cleaning, the valve seat should preferably be cleaned with a lint-free cloth moistened with alcohol.
- Allow the valve seat to dry.

Installing the valve

- 1 Wipe the seal with a lint-free cloth slightly moistened with vacuum oil.

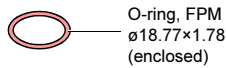

- 2 Be careful to insert the O-ring level into the groove without twisting it.

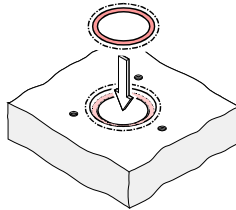

- 3 Remove the protective lid and insert the valve into the valve seat.

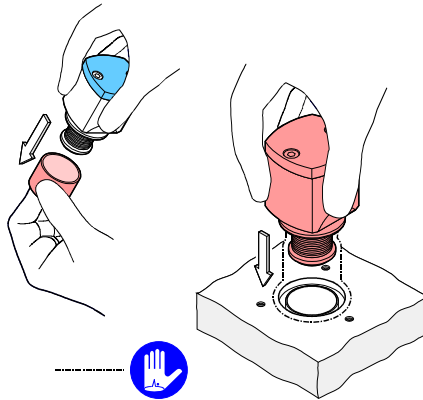

- 4 Lock the valve with 3 claw grips.

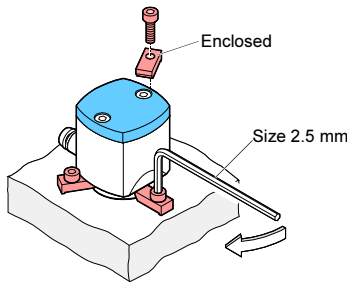

Compressed Air Connection

DANGER

Caution: compressed air
Unprofessionally handling compressed air can cause physical injury.
Adhere to the relevant regulations and take the necessary precautions when handling compressed air.

Installing the plastic tube

- Specifications for the plastic tube:
- $\varnothing 4 \text{ mm}$
 - bursting pressure $\geq 10 \text{ bar}$ (overpressure)
 - material: PA soft or PU.
- To ensure leak tightness of the instant push-in fitting
- cut the plastic tube square
 - make sure the outside of the plastic tube is not damaged.

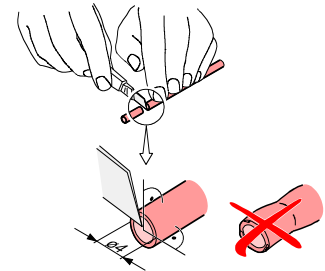

Push the plastic tube into the instant push-in fitting until the mechanical stop is reached. Check that it is correctly mounted by slightly pulling.

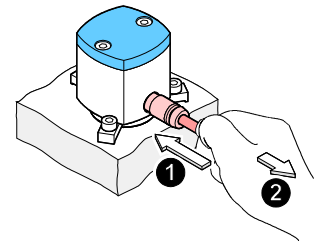

Compressed air control system

The compressed air control system has to be supplied by the end-user.

To reach the opening and closing times indicated in the "Technical Data", a pilot valve with a nominal diameter of $\geq 1 \text{ mm}$ is required.

If the nominal diameter of the pilot valve is $> 1 \text{ mm}$, the opening and closing time are not affected because there is an orifice with a diameter of 1 mm in the product.

Specifications of the compressed air

- free of oil
- dry
- free of particles $> 10 \mu\text{m}$
- 4 ... 8 bar overpressure

- After reassembly, a few switching cycles should be performed in order for the O-rings to perfectly adapt to the sealing surfaces. Take the necessary precautions for this procedure.



Operation

The product is ready for operation as soon as it has been installed.

Valve position

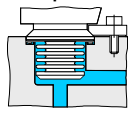
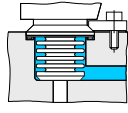
Compressed air	Valve position
Admitted	<p>open</p> 
Not admitted	<p>closed</p> 

Pressure difference Δp in closing direction

Caution

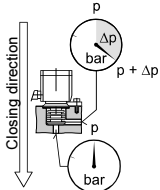

Caution: pressure difference
At $\Delta p > 3$ bar the valve can get damaged.
Avoid pressure differences $\Delta p > 3$ bar.

Pressure difference Δp in opening direction

Caution

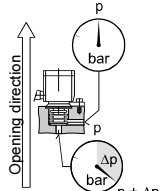

Caution: pressure difference
At $\Delta p > 3$ bar the valve is opened.
Avoid pressure differences $\Delta p > 3$ bar.

Opening to a pressure difference Δp

Caution

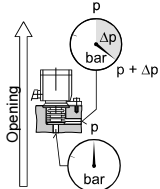

Caution: Pressure difference
At $\Delta p > 3$ bar the valve can get damaged.
Avoid pressure differences $\Delta p > 3$ bar.

Deinstallation

STOP DANGER



Caution: contaminated parts
Contaminated parts can be detrimental to health and environment.
Before beginning to work, find out whether any parts are contaminated. Adhere to the relevant regulations and take the necessary precautions when handling contaminated parts.

STOP DANGER



Caution: compressed air
Physical injury can result if a pressurized compressed air line is disconnected.
Before doing any work, turn off the compressed air supply and relieve the compressed air lines.

Caution



Caution: vacuum component
Dirt and damages impair the function of the vacuum component.
When handling vacuum components, take appropriate measures to ensure cleanliness and prevent damages.

Caution



Caution: dirt sensitive area
Touching the product or parts thereof with bare hands increases the desorption rate.
Always wear clean, lint-free gloves and use clean tools when working in this area.

Preconditions

- Vacuum system vented
- Compressed air supply has been interrupted
- Compressed air line is vented

Procedure

- 1 Press the thrust ring towards the valve and pull the plastic tube.

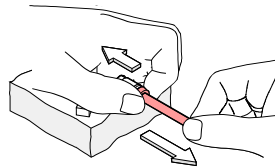

- 2 Unfasten the claw grips.

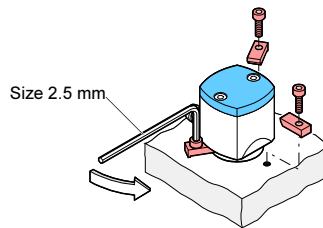

- 3 Remove the valve from the valve seat and place the protective lid.

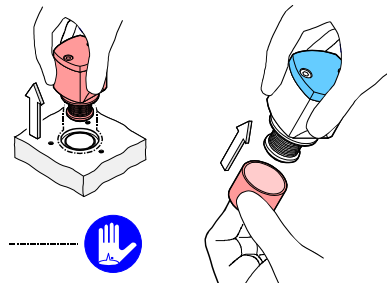

- 4 Carefully remove the seal without damaging the sealing surface (e.g. with a toothpick).

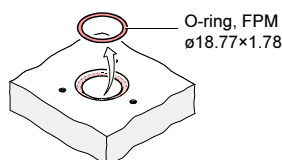

Returning the Product

WARNING



Caution: forwarding contaminated products
Contaminated products (e.g. radioactive, toxic, caustic or microbiological hazard) can be detrimental to health and environment.
Products returned to INFICON should preferably be free of harmful substances. Adhere to the forwarding regulations of all involved countries and forwarding companies and enclose a duly completed declaration of contamination.

Products that are not clearly declared as "free of harmful substances" are decontaminated at the expense of the customer. Products not accompanied by a duly completed declaration of contamination are returned to the sender at his own expense.

Disposal

STOP DANGER



Caution: contaminated parts
Contaminated parts can be detrimental to health and environment.
Before beginning to work, find out whether any parts are contaminated. Adhere to the relevant regulations and take the necessary precautions when handling contaminated parts.

WARNING



Caution: substances detrimental to the environment
Products or parts thereof (mechanical and electric components, operating fluids etc.) can be detrimental to the environment.
Dispose of such substances in accordance with the relevant local regulations.

Separating the components

After disassembling the product, separate its components according to the following criteria:

- Contaminated components
Contaminated components (radioactive, toxic, caustic, or biological hazard etc.) must be decontaminated in accordance with the relevant national regulations, separated according to their materials, and disposed of.
- Other components
Such components must be separated according to their materials and recycled.

Declaration of Contamination

The service, repair, and/or disposal of vacuum equipment and components will only be carried out if a correctly completed declaration has been submitted. Non-completion will result in delay. This declaration may only be completed (in block letters) and signed by authorized and qualified staff.

1 Description of product Type _____ Part number _____ Serial number _____	2 Reason for return _____ _____ _____																																				
3 Operating fluid(s) used (Must be drained before shipping.) _____ _____																																					
4 Process related contamination of product <table style="width: 100%; border-collapse: collapse;"> <tr> <td style="width: 30%;">toxic</td> <td style="width: 10%;">no <input type="checkbox"/> 1)</td> <td style="width: 10%;">yes <input type="checkbox"/></td> <td style="width: 10%;"></td> <td style="width: 10%;"></td> <td style="width: 10%;"></td> </tr> <tr> <td>caustic</td> <td>no <input type="checkbox"/> 1)</td> <td>yes <input type="checkbox"/></td> <td></td> <td></td> <td></td> </tr> <tr> <td>biological hazard</td> <td>no <input type="checkbox"/></td> <td>yes <input type="checkbox"/> 2)</td> <td></td> <td></td> <td></td> </tr> <tr> <td>explosive</td> <td>no <input type="checkbox"/></td> <td>yes <input type="checkbox"/> 2)</td> <td></td> <td></td> <td></td> </tr> <tr> <td>radioactive</td> <td>no <input type="checkbox"/></td> <td>yes <input type="checkbox"/> 2)</td> <td></td> <td></td> <td></td> </tr> <tr> <td>other harmful substances</td> <td>no <input type="checkbox"/> 1)</td> <td>yes <input type="checkbox"/></td> <td></td> <td></td> <td></td> </tr> </table> <div style="text-align: right; margin-top: 10px;"> <p>2) Products thus contaminated will not be accepted without written evidence of decontamination!</p> </div>		toxic	no <input type="checkbox"/> 1)	yes <input type="checkbox"/>				caustic	no <input type="checkbox"/> 1)	yes <input type="checkbox"/>				biological hazard	no <input type="checkbox"/>	yes <input type="checkbox"/> 2)				explosive	no <input type="checkbox"/>	yes <input type="checkbox"/> 2)				radioactive	no <input type="checkbox"/>	yes <input type="checkbox"/> 2)				other harmful substances	no <input type="checkbox"/> 1)	yes <input type="checkbox"/>			
toxic	no <input type="checkbox"/> 1)	yes <input type="checkbox"/>																																			
caustic	no <input type="checkbox"/> 1)	yes <input type="checkbox"/>																																			
biological hazard	no <input type="checkbox"/>	yes <input type="checkbox"/> 2)																																			
explosive	no <input type="checkbox"/>	yes <input type="checkbox"/> 2)																																			
radioactive	no <input type="checkbox"/>	yes <input type="checkbox"/> 2)																																			
other harmful substances	no <input type="checkbox"/> 1)	yes <input type="checkbox"/>																																			
<div style="border: 1px solid black; padding: 5px; margin-bottom: 10px;"> The product is free of any substances which are damaging to health yes <input type="checkbox"/> </div> <div style="border: 1px solid black; padding: 5px; margin-bottom: 10px;"> 1) or not containing any amount of hazardous residues that exceed the permissible exposure limits </div>																																					
5 Harmful substances, gases and/or by-products Please list all substances, gases, and by-products which the product may have come into contact with: <table border="1" style="width: 100%; border-collapse: collapse; margin-top: 5px;"> <thead> <tr> <th style="width: 20%;">Trade/product name Manufacturer</th> <th style="width: 20%;">Chemical name (preferably with formula)</th> <th style="width: 20%;">Precautions associated with substance</th> <th style="width: 20%;">Action in case of human contact</th> </tr> </thead> <tbody> <tr><td> </td><td> </td><td> </td><td> </td></tr> <tr><td> </td><td> </td><td> </td><td> </td></tr> <tr><td> </td><td> </td><td> </td><td> </td></tr> <tr><td> </td><td> </td><td> </td><td> </td></tr> </tbody> </table>		Trade/product name Manufacturer	Chemical name (preferably with formula)	Precautions associated with substance	Action in case of human contact																																
Trade/product name Manufacturer	Chemical name (preferably with formula)	Precautions associated with substance	Action in case of human contact																																		
6 Legally binding declaration: We hereby declare that the information on this form is complete and accurate and that we will assume any further costs that may arise. The contaminated product will be dispatched in accordance with the applicable regulations. <table style="width: 100%; margin-top: 10px;"> <tr> <td style="width: 50%;">Organization/company _____</td> <td style="width: 50%;">Post code, place _____</td> </tr> <tr> <td>Address _____</td> <td>Phone _____</td> </tr> <tr> <td>Phone _____</td> <td>Fax _____</td> </tr> <tr> <td>E-mail _____</td> <td></td> </tr> <tr> <td>Name _____</td> <td></td> </tr> </table> <table style="width: 100%; margin-top: 10px;"> <tr> <td style="width: 50%;">Date and legally binding signature _____</td> <td style="width: 50%;">Company stamp _____</td> </tr> </table>		Organization/company _____	Post code, place _____	Address _____	Phone _____	Phone _____	Fax _____	E-mail _____		Name _____		Date and legally binding signature _____	Company stamp _____																								
Organization/company _____	Post code, place _____																																				
Address _____	Phone _____																																				
Phone _____	Fax _____																																				
E-mail _____																																					
Name _____																																					
Date and legally binding signature _____	Company stamp _____																																				

This form can be downloaded from our website.

Copies: Original for addressee - 1 copy for accompanying documents - 1 copy for file of sender

Manufacturer's Declaration

as defined by the Directive relating to machinery 98/37/EC, Appendix IIb.

We, INFICON, hereby declare that putting the incomplete equipment mentioned below into operation is not permitted until evidence is given that the system into which that incomplete equipment shall be installed is in conformity with the provisions of the EC Directive relating to machinery.

Insert Valve

pneumatically operated
bellows sealed

VAP005-Z

Part number

250-045

Standards

Harmonized and international/national standards and specifications:

- EN 292-1/-2 (Safety of machinery)
- EN 294 (Safety distances to prevent danger zones being reached by the upper limbs)

Signatures

INFICON AG, Balzers

2 April 2002

Hans-Christoph Gehlhar
Product Manager

2 April 2002

Dr. Georg Sele
Technical Support Manager
Quality Representative



LI-9496 Balzers
Liechtenstein
Tel +423 / 388 3111
Fax +423 / 388 3700
reach.liechtenstein@inficon.com
www.inficon.com