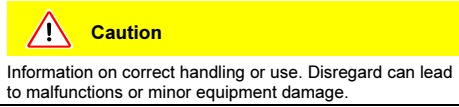
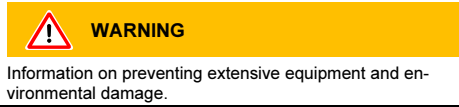
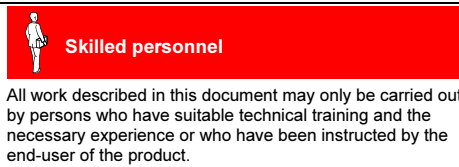

Symbols Used

Personnel Qualifications

General Safety Instructions

- Adhere to the applicable regulations and take the necessary precautions for the process media used. Consider possible reactions between the materials (→ "Technical Data") and the process media. Consider possible reactions of the process media due to the heat generated by the product.
 - Adhere to the applicable regulations and take the necessary precautions for all work you are going to do and consider the safety instructions in this document.
 - Before beginning to work, find out whether any vacuum components are contaminated. Adhere to the relevant regulations and take the necessary precautions when handling contaminated parts.
- Communicate the safety instructions to all other users.

Liability and Warranty

Inficon assumes no liability and the warranty becomes null and void if the end-user or third parties

- disregard the information in this document
- use the product in a non-conforming manner
- make any kind of interventions (modifications, alterations etc.) on the product
- use the product with accessories not listed in the corresponding product documentation.

The end-user assumes the responsibility in conjunction with the process media used.

Technical Data

Version	normally closed
Vacuum connection	ø5 mm / M14×1
Vacuum connection (accessories)	<ul style="list-style-type: none"> • Flange fitting DN 10 ISO-KF • Tube connection OD ¼" • Tube connection OD 6 mm
Nominal voltage	24 VDC ±10%
Nominal power	10 W
Duty cycle	100% (i.e. continuous duty possible)
Type of protection	IP 65 acc. to DIN 40 050
Conductance for air	0.3 l/s
Molecular flow	3 l/s
Laminar flow	
Mounting orientation	any
Switching frequency max.	300 / min ¹⁾
Cycles to first overhaul	≈ 2'000'000 ²⁾
Tightness	1×10 ⁻⁹ mbar l/s
Pressure range	1×10 ⁻⁸ mbar ... 10 bar (absolute)
Pressure difference Δp	
In closing direction	5 bar
In opening direction	1.5 bar
Opens against a pressure difference Δp	1 bar with 24 VDC
Closing time	7 ms ¹⁾
Opening time	30 ms ¹⁾
Temperatures	
Ambiance	5 ³⁾ ... 40 °C
Heat generation	60 °C (after 1¼ hours on continuous duty)
Bakeout	120 °C (without power) 150 °C (without coil)
Materials	
Housing	stainless steel 1.4301
Actuator	stainless steel 1.4105
Seals	FPM
Weight	0.26 kg

- ¹⁾ With pressure difference Δp = 0.
- ²⁾ Under clean operating conditions.
- ³⁾ -15 °C, if the ambiance is free of condensable gases.

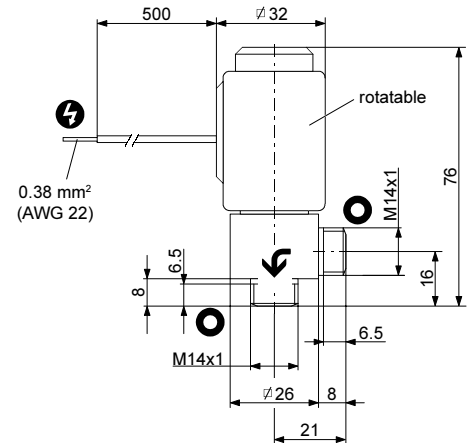
Dimensions

- Flow direction
- Electrical connection
- Lid

Angle Valve

electromagnetically actuated
normally closed
VAM005-X

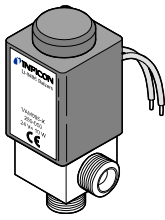

Instruction Sheet
Incl. Manufacturer's Declaration
sima07e1 (0102)

Product Identification

In all communications with Inficon, please specify the information on the product nameplate. For convenient reference copy that information into the space provided below.

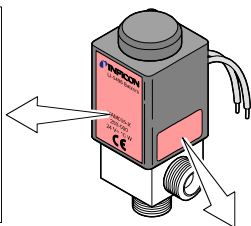
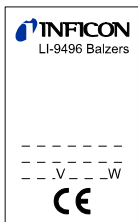

F-No:

Validity

This document applies to products with part number 250-000. The part number can be taken from the product nameplate. We reserve the right to make technical changes without prior notice. Dimensions in mm.

Intended Use

The VAM005-X is predominantly used in fast-cycling vacuum systems, e.g. for gas analysis and coating processes.

Functional Principle

The VAM005-X is opened electromagnetically and closed by the prestressed pressure spring. It will close, or will remain closed, on power loss.

Space requirements with accessories (part numbers of accessories → "Installation")

Flange fittings

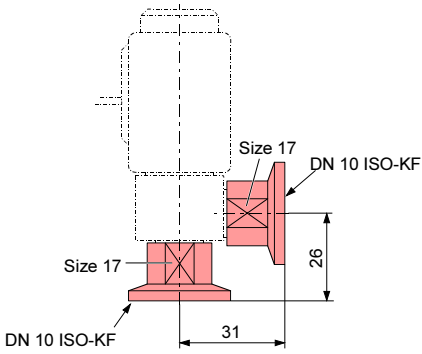

Tube connections

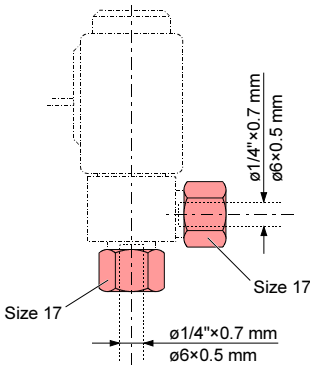

Flange fitting and tube connection

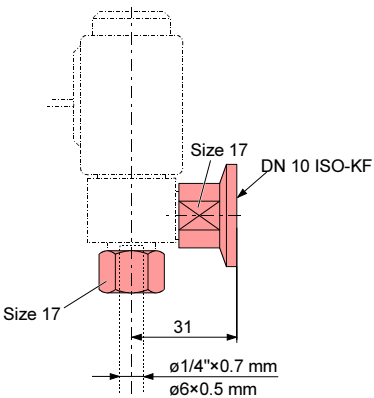

Installation

Vacuum Connection

Caution

Caution: vacuum component
Dirt and damages impair the function of the vacuum component.
When handling vacuum components, take appropriate measures to ensure cleanliness and prevent damages.

Caution

Caution: dirt sensitive area
Touching the product or parts thereof with one's bare hands increases the desorption rate.
Always wear clean, lint-free gloves and use clean tools when working in this area.

1 Remove the lids.

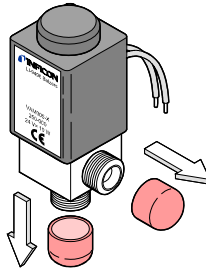

Keep the lids.

2 Mount the valve to the vacuum system using an accessory.
Accessories



Flange fitting
DN 10 ISO-KF
Part no. 250-080

Flange fitting
DN 10 ISO-KF
Part no. 250-080

Tube connection
OD 1/4"
ø1/4" x 0.7 mm
Part no. 250-085

Tube connection
OD 1/4"
ø1/4" x 0.7 mm
Part no. 250-085

Tube connection
OD 6 mm
ø6 x 0.5 mm
Part no. 250-086

Tube connection
OD 6 mm
ø6 x 0.5 mm
Part no. 250-086

See separate document for installation of the accessories.

Electrical Connection

Bringing the cable strands into the desired position

1 Remove the lid.

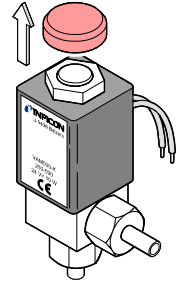

2 Unfasten the hexagon nut and rotate the solenoid coil until the cable strands are in the desired position.

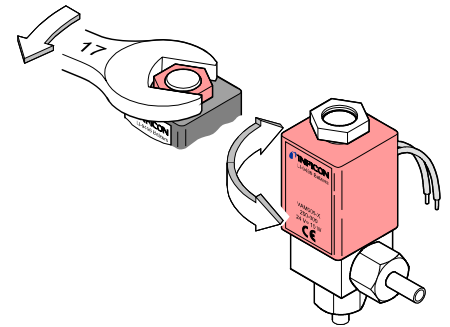

3 Tighten the hexagon nut with a torque of ≤ 3 Nm and place the lid.

Establishing the electrical connection

The electrical connection is established via the two cable strands. Adhere to the local regulations with regard to the installation.

Caution

Caution: switching of inductive loads (solenoid coil)
Inductive loads may considerably reduce the life of or even destroy contacts.
Preferably a clamping diode should be connected in parallel to the solenoid coil. The polarity should be chosen in such a way that the diode blocks when the normal operating voltage is applied.

Circuit diagram showing a contact, a clamping diode, and a solenoid coil connected in parallel.

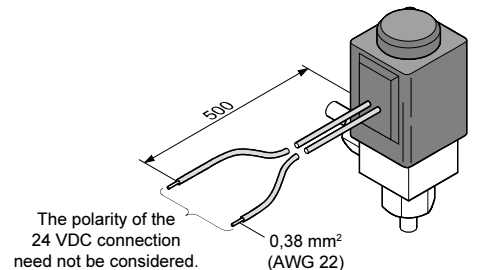

Operation

The product is ready for operation as soon as it has been installed.

The VAM005-X will close, or remain closed, on power loss.

STOP DANGER

Caution: hot surface
Touching the hot surface (>55 °C) can cause burns.
Wear protective gloves.

Pressure difference Δp in closing direction

Caution

Caution: pressure difference
With $\Delta p > 5$ bar the O-ring of the valve plate can get damaged.
Avoid pressure differences $\Delta p > 5$ bar.

Pressure difference Δp in opening direction

Caution

Caution: pressure difference
With $\Delta p > 1.5$ bar the valve is opened.
Avoid pressure differences $\Delta p > 1.5$ bar.

Opens against a pressure difference Δp

Caution

Caution: Pressure difference
With $\Delta p > 1$ bar the valve cannot open.
Avoid pressure differences $\Delta p > 1$ bar.

Deinstallation

STOP DANGER

Caution: contaminated parts
Contaminated parts can be detrimental to health and environment.
Before beginning to work, find out whether any parts are contaminated. Adhere to the relevant regulations and take the necessary precautions when handling contaminated parts.

Caution

Caution: vacuum component
Dirt and damages impair the function of the vacuum component.
When handling vacuum components, take appropriate measures to ensure cleanliness and prevent damages.

Caution

Caution: dirt sensitive area
Touching the product or parts thereof with one's bare hands increases the desorption rate.
Always wear clean, lint-free gloves and use clean tools when working in this area.

Preconditions

- Vacuum system vented
- Control system disconnected from the power source
- Valve cooled down to 55 °C

Procedure

- 1 Disconnect the product from the power source.
- 2 Disconnect the product from the vacuum system and place the lids.

Maintenance/Repair

→ Operating Manual sina07e1. It can be downloaded from our website.

Returning the Product

WARNING

Caution: forwarding contaminated products
Contaminated products (e.g. radioactive, toxic, caustic or microbiological hazard) can be detrimental to health and environment.
Products returned to Inficon should preferably be free of harmful substances. Adhere to the forwarding regulations of all involved countries and forwarding companies and enclose a duly completed declaration of contamination.

Products that are not clearly declared as "free of harmful substances" are decontaminated at the expense of the customer. Products not accompanied by a duly completed declaration of contamination are returned to the sender at his own expense.

Disposal

STOP DANGER

Caution: contaminated parts
Contaminated parts can be detrimental to health and environment.
Before beginning to work, find out whether any parts are contaminated. Adhere to the relevant regulations and take the necessary precautions when handling contaminated parts.

WARNING

Caution: substances detrimental to the environment
Products or parts thereof (mechanical and electric components, operating fluids etc.) can be detrimental to the environment.
Dispose of such substances in accordance with the relevant local regulations.

Separating the components

After disassembling the product, separate its components according to the following criteria:

- Contaminated components
Contaminated components (radioactive, toxic, caustic, or biological hazard etc.) must be decontaminated in acc. with the relevant national regulations, separated according to their materials, and disposed.
- Other components
Such components must be separated according to their materials and recycled.

Declaration of Contamination

The service, repair, and/or disposal of vacuum equipment and components will only be carried out if a correctly completed declaration has been submitted. Non-completion will result in delay.
This declaration may only be completed (in block letters) and signed by authorized and qualified staff.

1 Description of product Type _____ Article Number _____ Serial Number _____	2 Reason for return _____ _____ _____																				
↓																					
3 Operating fluid(s) used (Must be drained before shipping.) _____ _____																					
↓																					
4 Process related contamination of product: <table style="width: 100%; border: none;"> <tr> <td style="width: 40%;">toxic</td> <td style="width: 10%;">no <input type="checkbox"/> 1)</td> <td style="width: 10%;">yes <input type="checkbox"/></td> <td rowspan="6" style="width: 40%; text-align: center; vertical-align: middle;"> 2) Products thus contaminated will not be accepted without written evidence of decontamination! </td> </tr> <tr> <td>caustic</td> <td>no <input type="checkbox"/> 1)</td> <td>yes <input type="checkbox"/></td> </tr> <tr> <td>biological hazard</td> <td>no <input type="checkbox"/></td> <td>yes <input type="checkbox"/> 2)</td> </tr> <tr> <td>explosive</td> <td>no <input type="checkbox"/></td> <td>yes <input type="checkbox"/> 2)</td> </tr> <tr> <td>radioactive</td> <td>no <input type="checkbox"/></td> <td>yes <input type="checkbox"/> 2)</td> </tr> <tr> <td>other harmful substances</td> <td>no <input type="checkbox"/> 1)</td> <td>yes <input type="checkbox"/></td> </tr> </table> <p style="font-size: small; margin-top: 5px;">1) or not containing any amount of hazardous residues that exceed the permissible exposure limits</p>		toxic	no <input type="checkbox"/> 1)	yes <input type="checkbox"/>	 2) Products thus contaminated will not be accepted without written evidence of decontamination!	caustic	no <input type="checkbox"/> 1)	yes <input type="checkbox"/>	biological hazard	no <input type="checkbox"/>	yes <input type="checkbox"/> 2)	explosive	no <input type="checkbox"/>	yes <input type="checkbox"/> 2)	radioactive	no <input type="checkbox"/>	yes <input type="checkbox"/> 2)	other harmful substances	no <input type="checkbox"/> 1)	yes <input type="checkbox"/>	
toxic	no <input type="checkbox"/> 1)	yes <input type="checkbox"/>	 2) Products thus contaminated will not be accepted without written evidence of decontamination!																		
caustic	no <input type="checkbox"/> 1)	yes <input type="checkbox"/>																			
biological hazard	no <input type="checkbox"/>	yes <input type="checkbox"/> 2)																			
explosive	no <input type="checkbox"/>	yes <input type="checkbox"/> 2)																			
radioactive	no <input type="checkbox"/>	yes <input type="checkbox"/> 2)																			
other harmful substances	no <input type="checkbox"/> 1)	yes <input type="checkbox"/>																			
↓																					
5 Harmful substances, gases and/or by-products Please list all substances, gases, and by-products which the product may have come into contact with: <table border="1" style="width: 100%; border-collapse: collapse; margin-top: 5px;"> <thead> <tr> <th style="width: 25%;">Trade/product name</th> <th style="width: 25%;">Chemical name (or symbol)</th> <th style="width: 25%;">Precautions associated with substance</th> <th style="width: 25%;">Action if human contact</th> </tr> </thead> <tbody> <tr><td> </td><td> </td><td> </td><td> </td></tr> <tr><td> </td><td> </td><td> </td><td> </td></tr> <tr><td> </td><td> </td><td> </td><td> </td></tr> <tr><td> </td><td> </td><td> </td><td> </td></tr> </tbody> </table>		Trade/product name	Chemical name (or symbol)	Precautions associated with substance	Action if human contact																
Trade/product name	Chemical name (or symbol)	Precautions associated with substance	Action if human contact																		
↓																					
6 Legally binding declaration: I/we hereby declare that the information on this form is complete and accurate and that I/we will assume any further costs that may arise. The contaminated product will be dispatched in accordance with the applicable regulations. Organization/company _____ Address _____ Post code, place _____ Phone _____ Fax _____ Email _____ Name _____ Date and legally binding signature _____ Company stamp _____																					

This form can be downloaded from our website.

Copies:
Original for addressee - 1 copy for accompanying documents - 1 copy for file of sender

Manufacturer's Declaration

as defined by the Directive relating to machinery 98/37/EC, Appendix IIb

We, Inficon, hereby declare that putting the incomplete equipment mentioned below into operation is not permitted until evidence is given that the system into which that incomplete equipment shall be installed is in accordance with the provisions of the EC Directive relating to machinery.

We also declare that the equipment mentioned below complies with the provisions of the Directive relating to electrical equipment designed for use within certain voltage limits 73/23/EEC.

Angle Valve

electromagnetically actuated
normally closed

VAM005-X

Part number

250-000

Standards

Harmonized and international/national standards and specifications:

- EN 292-1/-2 (Safety of machinery)
- EN 60204-1 (Electrical equipment of machines)

Signatures

Inficon AG, Balzers

19 February 2001

Robert Polacek
Product management

19 February 2001

Dr. Georg Sele
Technical Support Manager
Quality Representative



LI-9496 Balzers
Liechtenstein
Tel +423 / 388 3111
Fax +423 / 388 3700
reach.liechtenstein@inficon.com
www.inficon.com