

## All-Metal Angle Valve

DN 16 ... 63 CF  
manually actuated  
bellows sealed  
metal valve seat seal

VAH016 ... 063-U

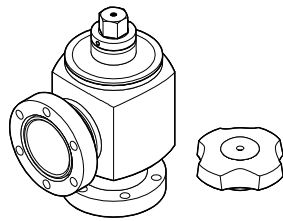

Instruction Sheet  
Incl. Manufacturer's Declaration

sima01e1-a (2005-09)

### Product Identification

In all communications with INFICON, please specify the information on the product nameplate. For convenient reference copy that information into the space provided below.

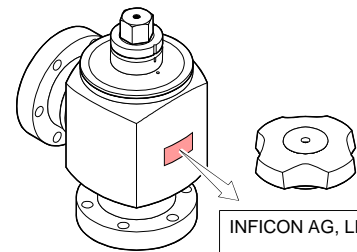

INFICON AG, LI-9496 Balzers  
Model: \_\_\_\_\_  
PN: \_\_\_\_\_  
SN: \_\_\_\_\_

### Validity

This document applies to products with the following part numbers:

250-730 (VAH016-U DN 16 CF-R)  
250-735 (VAH040-U DN 40 CF-R)  
250-740 (VAH063-U DN 63 CF-R)

The part number (PN) can be taken from the product nameplate.

If not indicated otherwise in the legends, the illustrations in this document correspond to the valve with the nominal diameter DN 40. They apply to valves with other nominal diameters by analogy.

We reserve the right to make technical changes without prior notice.

### Intended Use

The product is used as shut-off valve for HV and UHV applications. It can be baked out at 300 °C. The welded housing is suited for high-purity and toxic gases.

### Description

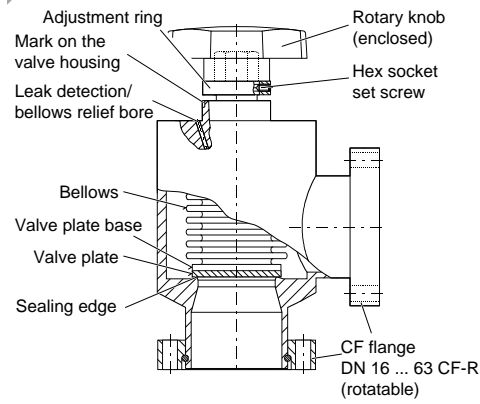

### Functional Principle

The sealing effect of the Angle valve is achieved by pressing the valve plate against the sealing edge.  
The housing is welded.

### Safety

#### Symbols Used

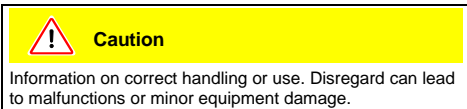
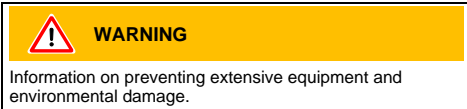

→ See document ...

#### Personnel Qualifications

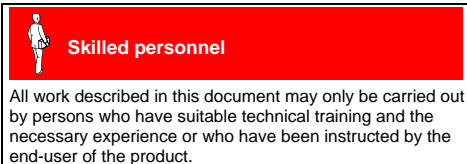

### General Safety Instructions

- Adhere to the applicable regulations and take the necessary precautions for the process media used. Consider possible reactions between the materials (→ Technical Data) and the process media.
- Adhere to the applicable regulations and take the necessary precautions for all work you are going to do and consider the safety instructions in this document.
- Before beginning to work, find out whether any vacuum components are contaminated. Adhere to the relevant regulations and take the necessary precautions when handling contaminated parts.

Communicate the safety instructions to all other users.

### Liability and Warranty

INFICON assumes no liability and the warranty becomes null and void if the end-user or third parties

- disregard the information in this document
- use the product in a non-conforming manner
- make any kind of interventions (modifications, alterations etc.) on the product
- use the product with accessories not listed in the corresponding product documentation.

The end-user assumes the responsibility in conjunction with the process media used.

### Technical Data

Connection flanges, rotatable	any
VAH016-U	DN 16 CF-R
VAH040-U	DN 40 CF-R
VAH063-U	DN 63 CF-R
Installation angle	any
Flow direction	any
Tightness	1×10 <sup>-12</sup> mbar/s
Pressure range	1×10 <sup>-11</sup> mbar ... 4 bar (absolute)
Bursting pressure	8 bar
Conductance <sup>1)</sup>	
VAH016-U	3 l/s
VAH040-U	38 l/s
VAH063-U	100 l/s
Temperatures	
ambience	0 °C ... 55 °C
operation	≤300 °C
bakeout	≤300 °C
(without rotary knob, closed, pressure in vacuum system <1×10 <sup>-4</sup> mbar or vacuum system vented with inert gas)	
rotary knob	≤80 °C
continuous	80 ... 110 °C
temporary	+5 ... +45 °C
storage	-15 ... +45 °C <sup>2)</sup>
Temperature increase	
VAH016-U	≤4 °C/minute
VAH040-U	≤4 °C/minute
VAH063-U	≤2 °C/minute
Closing torque	
VAH016-U	2 ... 10 Nm
VAH040-U	8 ... 30 Nm
VAH063-U	30 ... 60 Nm
Service life of sealing plate (cold closing operations)	1000 cycles
Lift (opening)	
VAH016-U	12 mm
VAH040-U	23 mm
VAH063-U	33 mm
Materials	
housing	stainless steel 1.4301
spindle	
VAH016-U	st. steel 1.4301 <sup>3)</sup>
VAH040-U, VAH063-U	CuSn8 2.1030.26
spindle flange	stainless steel 1.4301
bellows	stainless steel 1.4541
valve plate base	st. steel 1.4301 ESU
valve plate	
forming ring	stainless steel 1.4301
sealing plate	copper
rotary knob	PA 15% GF
Weight	
VAH016-U	0.4 kg
VAH040-U	2.0 kg
VAH063-U	5.0 kg

- For air with molecular flow.
- Ambience free of condensable gases.
- Older Types: CuSn8 2.1030.26

#### Dimensions [mm]

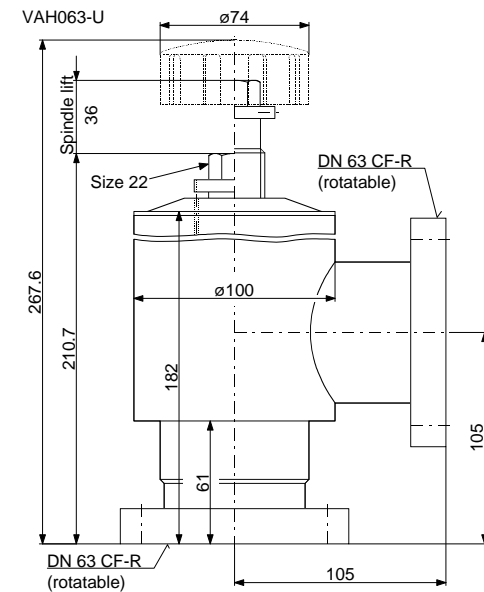
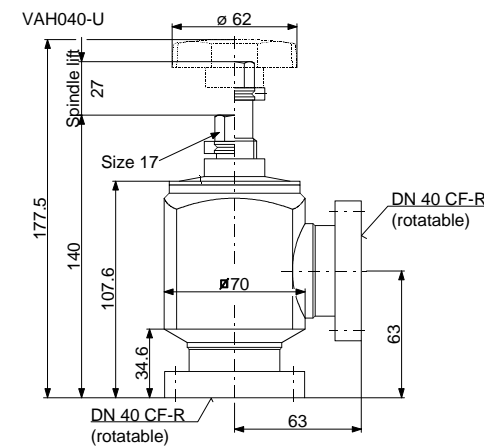
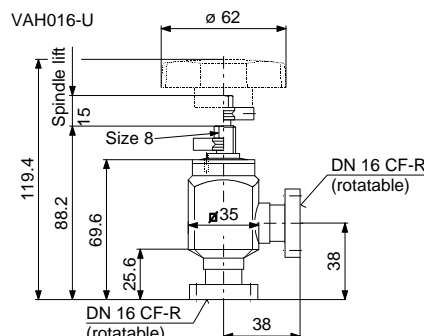

### Installation

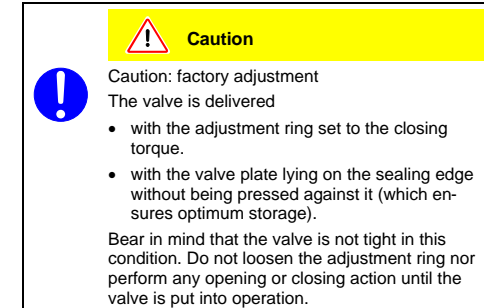
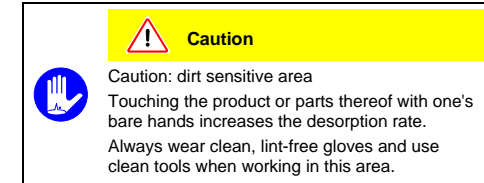
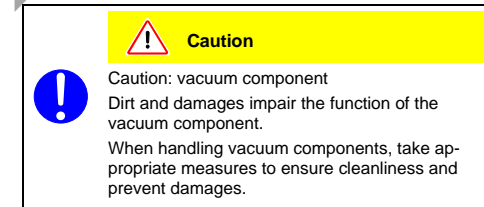

The protective packaging should not be removed until shortly before installation. Even the slightest contamination could cause leaks.

### Installation

#### Space Requirements

Make sure the valve can be operated without any risk of bodily injury.

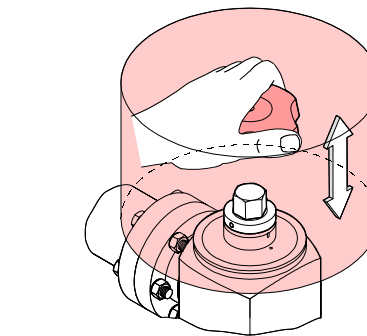
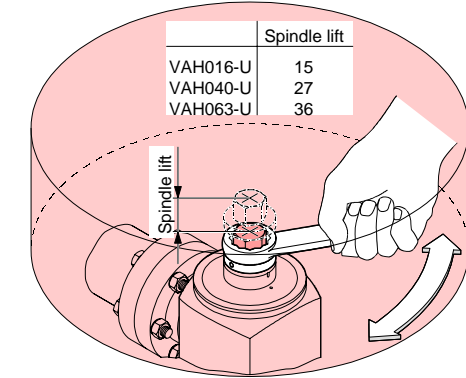

#### Flange Connection

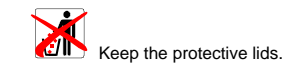
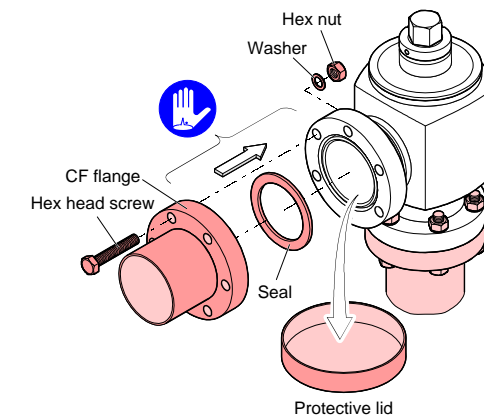

Flange	Seal	Pieces	Ordering number
DN 16 CF	copper	10	213-371
	copper, silver-plated	10	213-381
DN 40 CF	copper	10	213-372
	copper, silver-plated	10	213-382
DN 63 CF	copper	10	213-373
	copper, silver-plated	10	213-383

Flange	Hex head screw	Number of screws	Required torque
DN 16 CF	M4 x 20 mm	6 per flange	4 Nm
DN 40 CF	M6 x 35 mm	6 per flange	10 Nm
DN 63 CF	M8 x 50 mm	6 per flange	20 Nm

### Start-Up

#### Bakeout

It is good practice to bake out new valves and valves the inner parts of which have been exposed to atmosphere for some time, e.g. with a heating sleeve.

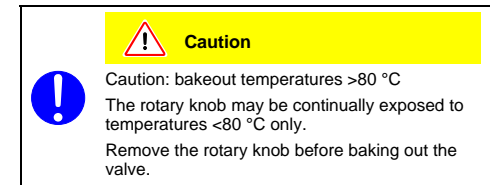
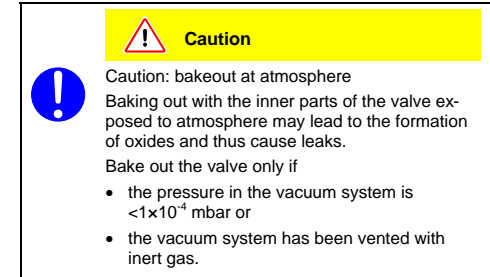
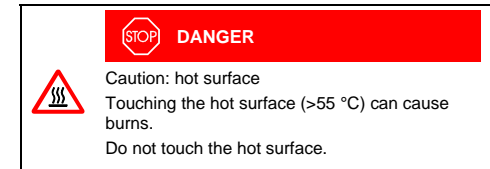

#### Close the valve ...

Using a ring wrench, turn the hex head until mark ① on the adjustment ring is in line with the mark on the valve housing.

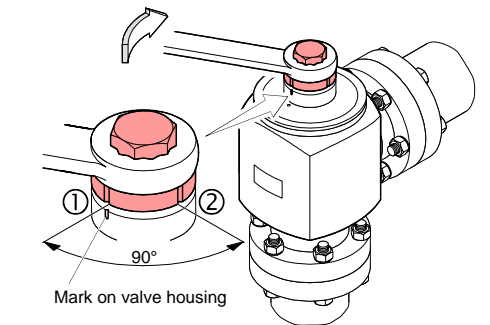

#### ... and bake it out.

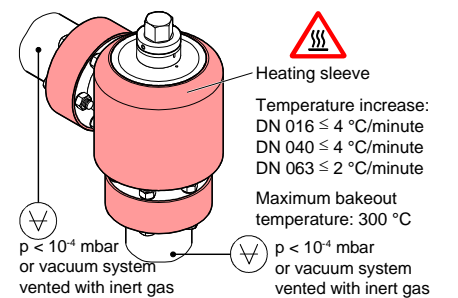

The valve is closed and ready for use now.



## Operation

Prevent the entry of dirt, dust, or other abrasive contamination into the valve. Even very small particles on the sealing surfaces may cause leaks.

**STOP DANGER**

**Caution: hot surface**  
Touching the hot surface (>55 °C) can cause burns.  
Wear protective gloves.

**Caution**

**Caution: bakeout at atmosphere**  
Baking out with the inner parts of the valve exposed to atmosphere may lead to the formation of oxides and thus cause leaks.  
Bake out the valve only if

- the pressure in the vacuum system is <math>1 \times 10^{-4}</math> mbar or
- the vacuum system has been vented with inert gas.

**Caution**

**Caution: position of the adjustment ring**  
Closing the valve with an incorrectly set adjustment ring may cause damages.  
Close the valve with the minimum torque using a torque wrench. Check that the valve is tight. If it is not yet tight, gradually increase the closing torque in small steps ( $\Delta\alpha \approx 5^\circ$ ) until the valve is tight. Do not exceed the maximum closing torque.

	Closing torque	
	minimum	maximum
VAH016-U	2 Nm	10 Nm
VAH040-U	8 Nm	30 Nm
VAH063-U	30 Nm	60 Nm

## Closing the Angle Valve

### 1 Operating temperature >55 °C

Using a ring wrench, position the valve plate on the sealing edge by turning the hex head clockwise until an increased resistance can be felt.

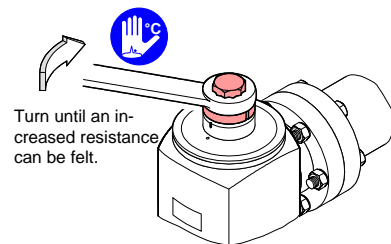

### Operating temperature ≤55 °C

Position the valve plate on the sealing edge by turning the rotary knob clockwise until an increased resistance can be felt. Remove the rotary knob.

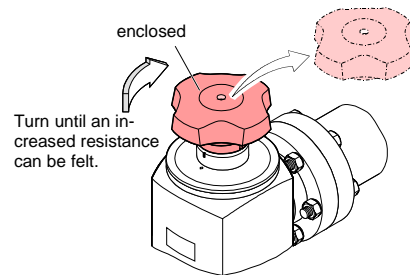

### 2 Close the valve by turning the hex head clockwise with a ring wrench until mark ① on the adjustment ring is in line with the mark on the valve housing. Remove the ring wrench.

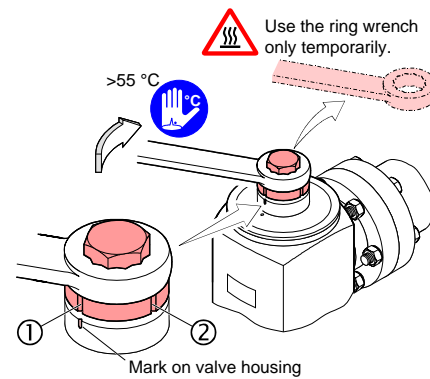

### 3 Check that the valve is tight. If it is not yet tight, keep gradually turning the hex head in small steps ( $\Delta\alpha \approx 5^\circ$ ) until the valve is tight. However, do not turn the hex head any further when mark ② on the adjustment ring is in line with the mark on the valve housing ( $\alpha = 90^\circ$ ).

**Caution**

**Caution: maximum closing torque**  
The maximum closing torque (mark ② on the adjustment ring is in line with the mark on the valve housing) must not be exceeded. If the maximum torque is exceeded, the sealing surfaces of the valve and/or spindle may get damaged.  
When the maximum closing torque has been reached, it is recommended to exchange the valve plate before running any further processes (→ [1]).

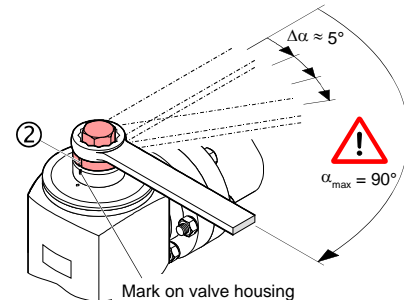

- A leak test must be performed if in a process
- the temperature was significantly increased by the heater and/or due to the process itself
  - the bakeout time was significantly increased.

## Opening the Angle Valve

The maximum opening of the valve is limited by a mechanical stop.

### 1 Open the valve by turning the hex head counter-clockwise with a ring wrench until the resistance decreases. Remove the ring wrench.

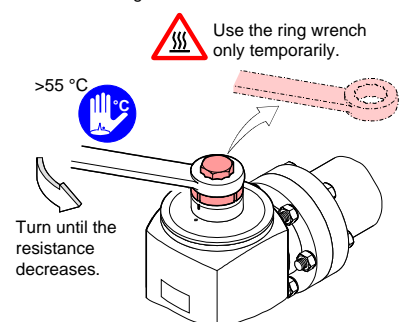

### 2 Operating temperature >55 °C

Continue opening the valve by turning the hex head counter-clockwise with the ring wrench. Remove the ring wrench.

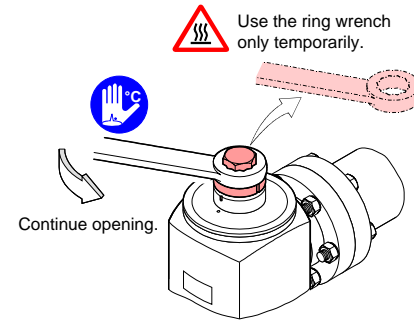

### Operating temperature ≤55 °C

Continue opening the valve by turning the rotary knob counter-clockwise. Remove the rotary knob.

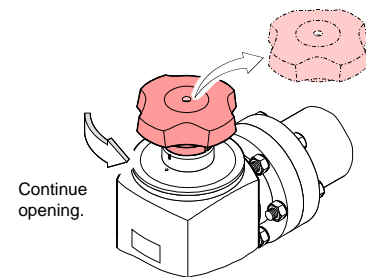

## Deinstallation

**STOP DANGER**

**Caution: contaminated parts**  
Contaminated parts can be detrimental to health and environment.  
Before beginning to work, find out whether any parts are contaminated. Adhere to the relevant regulations and take the necessary precautions when handling contaminated parts.

**Caution**

**Caution: vacuum component**  
Dirt and damages impair the function of the vacuum component.  
When handling vacuum components, take appropriate measures to ensure cleanliness and prevent damages.

Vent the vacuum system and wait until the valve has cooled down to <math>50^\circ\text{C}</math>.

Detach the flanges and put the protective lids in place.

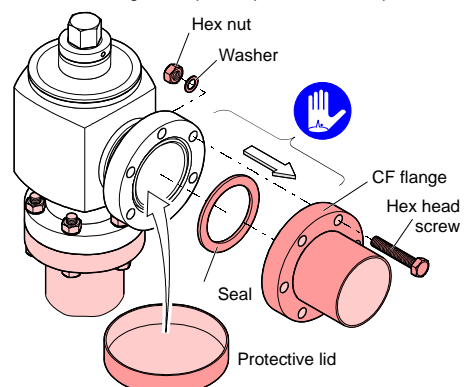

When the valve is reinstalled, replacing the seals is recommended (→ "Installation").

## Maintenance/Repair

→ [1]

## Storage

**Caution**

**Caution: vacuum component**  
Inappropriate storage leads to an increase of the desorption rate and/or may result in mechanical damage of the product.

- Cover the vacuum parts of the product with protective lids or grease free aluminum foil.
- Close the valve with the rotary knob until an increased resistance can be felt. The valve plate is now lying on the sealing edge without being pressed against it (which ensures optimum storage).
- Do not exceed the admissible storage temperature range (→ Technical Data).

## Returning the Product

**WARNING**

**Caution: forwarding contaminated products**  
Contaminated products (e.g. radioactive, toxic, caustic or microbiological hazard) can be detrimental to health and environment.  
Products returned to INFICON should preferably be free of harmful substances. Adhere to the forwarding regulations of all involved countries and forwarding companies and enclose a duly completed declaration of contamination.

Products that are not clearly declared as "free of harmful substances" are decontaminated at the expense of the customer.

Products not accompanied by a duly completed declaration of contamination are returned to the sender at his own expense.

## Disposal

**STOP DANGER**

**Caution: contaminated parts**  
Contaminated parts can be detrimental to health and environment.  
Before beginning to work, find out whether any parts are contaminated. Adhere to the relevant regulations and take the necessary precautions when handling contaminated parts.

**WARNING**

**Caution: substances detrimental to the environment**  
Products or parts thereof (mechanical and electric components, operating fluids etc.) can be detrimental to the environment.  
Dispose of such substances in accordance with the relevant local regulations.

## Separating the components

After disassembling the product, separate its components according to the following criteria:

- Contaminated components  
Contaminated components (radioactive, toxic, caustic, or biological hazard etc.) must be decontaminated in accordance with the relevant national regulations, separated according to their materials, and disposed of.
- Other components  
Such components must be separated according to their materials and recycled.

## Further Information

[1] [www.inficon.com](http://www.inficon.com)  
Operating Manual  
All-metal Angle Valve VAH016 ... 063-U  
sina01e1  
INFICON AG, LI-9496 Balzers, Liechtenstein

## Declaration of Contamination

The service, repair, and/or disposal of vacuum equipment and components will only be carried out if a correctly completed declaration has been submitted. Non-completion will result in delay. This declaration may only be completed (in block letters) and signed by authorized and qualified staff.

**1 Description of product**  
Type \_\_\_\_\_  
Part number \_\_\_\_\_  
Serial number \_\_\_\_\_

**2 Reason for return**  
\_\_\_\_\_

**3 Operating fluid(s) used**  
(Must be drained before shipping.)  
\_\_\_\_\_

**4 Used in copper process**  
no  yes  Seal product in plastic bag and mark it with a corresponding label.

**5 Process related contamination of product:**

	no <input type="checkbox"/> 1)	yes <input type="checkbox"/> 1)	yes <input type="checkbox"/> 2)
toxic	<input type="checkbox"/>	<input type="checkbox"/>	<input type="checkbox"/>
corrosive	<input type="checkbox"/>	<input type="checkbox"/>	<input type="checkbox"/>
biological hazard	<input type="checkbox"/>	<input type="checkbox"/>	<input type="checkbox"/>
explosive	<input type="checkbox"/>	<input type="checkbox"/>	<input type="checkbox"/>
radioactive	<input type="checkbox"/>	<input type="checkbox"/>	<input type="checkbox"/>
other harmful substances	<input type="checkbox"/>	<input type="checkbox"/>	<input type="checkbox"/>

1) or not containing any amount of hazardous residues that exceed the permissible exposure limits

2) Products thus contaminated will not be accepted without written evidence of decontamination.

The product is free of any substances which are damaging to health. yes

**6 Harmful substances, gases and/or by-products**  
Please list all substances, gases, and by-products which the product may have come into contact with:

Trade/product name manufacturer	Chemical name (or symbol)

Precautions associated with substance	Action if human contact

**7 Legally binding declaration:**  
We hereby declare that the information on this form is complete and accurate and that we will assume any further costs that may arise. The contaminated product will be dispatched in accordance with the applicable regulations.

Organization/company \_\_\_\_\_  
Address \_\_\_\_\_  
Post code, place \_\_\_\_\_  
Phone \_\_\_\_\_ Fax \_\_\_\_\_  
Email \_\_\_\_\_  
Name \_\_\_\_\_  
Company stamp \_\_\_\_\_

This form can be downloaded from our website.  
Copies: Original for addressee  
1 copy for accompanying documents  
1 copy for file of sender

## Manufacturer's Declaration

as defined by the Directive relating to machinery 98/37/EC, Appendix I b

We, INFICON, hereby declare that putting the incomplete equipment mentioned below into operation is not permitted until evidence is given that the system into which that incomplete equipment shall be installed is in conformity with the provisions of the EC Directive relating to machinery.

## All-Metal Angle Valve

DN 16 ... 63 CF  
manually actuated  
bellows sealed  
metal valve seat seal  
VAH016 ... 063-U

## Part numbers

250-730  
250-735  
250-740

## Standards

Harmonized and international/national standards and specifications:  
• ISO 3669

## Signatures

INFICON AG, Balzers

11 October 2005

*Marco Kern*

Marco Kern  
Product Marketing Manager

11 October 2005

*G. Sele*

Georg Sele  
Technical Support Manager  
Quality Representative



LI-9496 Balzers  
Liechtenstein  
Tel +423 / 388 3111  
Fax +423 / 388 3700  
reachus@inficon.com  
www.inficon.com